

(19) **DANMARK**

(10) **DK/EP 3139984 T3**



(12) **Oversættelse af
europæisk patentskrift**

Patent- og
Varemærkestyrelsen

-
- (51) Int.Cl.: **A 61 M 11/00 (2006.01)** **A 61 M 15/00 (2006.01)** **B 05 B 11/00 (2006.01)**
- (45) Oversættelsen bekendtgjort den: **2021-07-19**
- (80) Dato for Den Europæiske Patentmyndigheds bekendtgørelse om meddelelse af patentet: **2021-04-28**
- (86) Europæisk ansøgning nr.: **15727873.0**
- (86) Europæisk indleveringsdag: **2015-05-04**
- (87) Den europæiske ansøgnings publiceringsdag: **2017-03-15**
- (86) International ansøgning nr.: **EP2015000902**
- (87) Internationalt publikationsnr.: **WO2015169430**
- (30) Prioritet: **2014-05-07 EP 14001603** **2015-03-25 EP 15020044**
- (84) Designerede stater: **AL AT BE BG CH CY CZ DE DK EE ES FI FR GB GR HR HU IE IS IT LI LT LU LV MC MK MT NL NO PL PT RO RS SE SI SK SM TR**
- (73) Patenthaver: **Boehringer Ingelheim International GmbH, Binger Strasse 173, 55216 Ingelheim am Rhein, Tyskland**
- (72) Opfinder: **MUELLER, Markus, Anton-Bruckner-Straße 12, 93413 Cham, Tyskland**
EICHER, Joachim, Boehringer Ingelheim GmbH, Corporate Patents, Binger Straße 173, 55216 Ingelheim am Rhein, Tyskland
WINKLER, Robert Gerhard, Boehringer Ingelheim GmbH, Corporate Patents, Binger Straße 173, 55216 Ingelheim am Rhein, Tyskland
- (74) Fuldmægtig i Danmark: **AWA Denmark A/S, Strandgade 56, 1401 København K, Danmark**
- (54) Benævnelse: **FORSTØVER**
- (56) Fremdragne publikationer:
WO-A1-01/03851
WO-A1-96/39337
WO-A1-2012/162305
WO-A2-2012/160047
US-A1- 2003 100 867
US-B2- 7 823 584

DESCRIPTION

[0001] The present invention relates to a nebulizer configured to nebulize a fluid.

[0002] WO 2012/162305 A1 discloses a nebulizer. A container can be inserted into a housing of the nebulizer. The housing is closed by a lower housing part. By rotating the housing part the drive spring can be put under tension and fluid can be sucked into a compression chamber of the pressure generator. Simultaneously, the container is moved into the lower housing part in a stroke movement within the nebulizer and when tensioned for the first time the container may be pierced through its base by a piercing element in the lower housing part to allow venting of the container. After manual pressing a button, the drive spring is released and moves the delivery tube into the pressure chamber so that the fluid is put under pressure by the drive spring and is delivered or atomized through a nozzle into a mouthpiece as an aerosol, without the use of propellant gas. Thus, the container is moving axially forth and back during conveying of the fluid to be nebulized, and during pressure generation and nebulization.

[0003] The container of the nebulizer of WO 2012/162305 A1 may be connected inseparably with the housing part by a securing device forming a transportation lock for holding the container unmovable in a delivery state.

[0004] The nebulizer of WO 2012/162305 A1 comprises an indicator device for counting and/or indicating a number of uses performed or still possible. The indicator device blocks further use in a locked state when a predetermined number of uses has been reached or exceeded with the current container. Then, the container can be replaced together with a housing part and the nebulizer can be used further with the new

[0005] In the nebulizer of WO 2012/16305 A1, a counter device arranged preferably at a lower housing part counts the actuations or operations of the nebulizer or the discharged doses. Preferably, the counter device counts actuations or operations by detecting the rotation of an inner part relative to the upper part of the housing. With other words, the counter device may count the tensioning the nebulizer or its drive spring. The counter device may control or provide preferably locking of the nebulizer, indicating any required container replacement and/or container counting. For this purpose, the counter or a rider thereof comprises preferably an actuation part. The counter device is associated to the respective housing part and, thus, preferably to only one container and counts operations of the nebulizer with the respective container, i.e. counts (only) the number of doses of fluid removed or still removable from this container. When a predetermined number of operations or actuations of the nebulizer has been reached, the nebulizer is blocked against further use with the current container. This blocking is also called first locked state. The first locked state is entered preferably by means of the counter device. Particularly, the rider or its actuation part reach an upper axial position in this state and actuate a respective stop element or contact element of a locking element, said stop element or contact element being in blocking position or engagement with a stop portion of a container number indicator member. Thus, the stop element or contact element is

preferably flexed or deformed such that the previously stopped stop portion can pass and the indicator member is free to index one step further by the force of a spring. Said indexing of the indicator member by one step leads to the first locked state. By the above indexing of the member to reach the first locked state, the nebulizer is locked against further use. This is achieved in particular in that the indicator member drives a lock to lock the nebulizer against further actuation, preferably against further tensioning of the drive spring and/or against rotating of the housing part. This is preferably realized in that the rotation of the indicator member flexes the lock or portion of the locking member radially outwards so that the flexed portion leaves its non-locking position, into which it is biased, and locks further rotation of the inner part relative to the upper housing part.

[0006] US 7,823,584 B2 discloses a similar nebulizer, wherein a counter device can be integrated into a housing part that is exchangeable or replaceable together with the container, which is inseparable from the housing part.

[0007] WO 2007/104694 A1 discloses an inhaler for powdery substances with an indicator device which may comprise a worm gear for driving an indicator

[0008] Other nebulizers or spray dispensers with indicator and locking devices are known from US 2003/100867 A1, WO 01/03851 A1, WO 96/39337 A1 and WO 2012/160047 A2. Object of the present invention is to provide a nebulizer allowing easy and/or secure operation and handling and/or a compact and/or reliable construction, preferably while allowing replacement of the container without replacement of any housing part of the nebulizer.

[0009] The above object is achieved by a nebulizer according to claim 1. Preferred embodiments are subject of the subclaims.

[0010] The present invention relates to a nebulizer for nebulizing a fluid, preferably liquid medicament, from a replaceable container containing the fluid. An indicator device is provided for counting and/or indicating the number of uses already performed or still possible with the container.

[0011] The indicator device or an associated blocking device can lock the container and/or nebulizer or can cause the blocking of the container and/or nebulizer against further use in a locked state when a predetermined number of uses has been reached or exceeded with the respective container.

[0012] According to the present invention, the indicator device is arranged at the container and moveable together with the container axially within the nebulizer during nebulization and/or tensioning of the nebulizer. The indicator device is adapted to control the locking device by means of a mechanical coupling or control device. In particular, the mechanical coupling or control device allows that the axially moveable indicator device can control the locking device which, in turn, is preferably arranged in a part of the nebulizer that is not axially moveable together with the container and indicator device during tensioning and/or nebulization. Thus, it

is possible to directly combine and connect the container and the associated indicator device, in particular inseparably, wherein the locking device is arranged at the nebulizer and can be reused when the container and indicator device are replaced after use. The control device allows a mechanical control or coupling between the indicator device and the locking device. Consequently, an easy and/or secure operation and handling are possible because only the container and connected indicator device have to be replaced after use.

[0013] Preferably, the nebulizer comprises a housing part which can be detached from the nebulizer or opened for replacing the container.

[0014] According to one embodiment, the housing part may form the mechanical coupling or control device. This allows a simple and reliable construction.

[0015] According to another preferred embodiment, the control device is arranged in or connected with the housing part. This facilitates a simple construction or assembly of components.

[0016] Preferably, the indicator device contains a counter or indicator element that, directly or indirectly via a transmission, is indexed or preferably stepwise moved by interaction with a driving part upon or during actuation or charging / tensioning of the nebulizer or axial movement.

[0017] Preferably, when a predetermined number of uses has been reached or exceeded with the current container, the interaction of the counter or indication element or of an associated transmission with the driving part stops. Preferably simultaneously with the termination of the interaction or during the next tensioning of the nebulizer, the control device effects the actuation of the locking device.

[0018] Preferably, the housing part is not opened automatically by the interaction of the indicator device with the mechanical coupling or control device when initiating or entering the locked state. This minimizes the forces that occur and/or results in an easy handling, in particular tensioning, of the nebulizer when or before entering the locked state.

[0019] Preferably, the control device is not locked in the locked state or its actuated state as well, but can be reused. In this case, the housing part including the control device have not to be replaced, but only the container and indicator device have to be replaced when the nebulizer is to be reused.

[0020] Further, it is possible that the container with the indicator device on one hand and the housing part with the control device on the other hand are inseparably connected.

[0021] Preferably the nebulizer and/or container cannot be used anymore in the locked state when the indicator device has detected that a predetermined number of uses has been reached or exceeded, in particular with the respective container.

[0022] The indicator device may either directly or indirectly block or initiate or trigger locking of the nebulizer and/or container against further use. In particular, the indicator device may directly actuate the blocking device or indirectly initiate actuation of the locking device.

[0023] Preferably, the nebulizer is blocked (automatically) also against further use or tensioning if the nebulizer housing or housing part is at least partially open or opened or if, with other words, when the nebulizer or its housing is not (completely) closed.

[0024] It is also possible that the nebulizer is not immediately blocked against further use when the indicator device enters the locked state. Instead, the indicator device may initiate or cause or trigger in its locked state that the locking device is going to block the nebulizer against further use, e.g. during the next actuation or tensioning or the like. Thus, the locking device may enter its locking state later, e.g. after at least partial opening of the nebulizer and/or at least partial tensioning of the nebulizer or rotation of the housing part or inner part of the nebulizer or the like.

[0025] Therefore, the blocking of the nebulizer can be initiated or caused by the indicator device indirectly in the sense of later, e.g. during further handling, operation, actuation or the like. Thus, the indicator device blocks or initiates or causes blocking of the nebulizer and/or container against further use also preferably in the sense of the present invention.

[0026] Preferably, the blocking of the nebulizer against further use can be overcome by replacing the container, in particular including the indicator device, against one not yet used.

[0027] The indicator device is preferably inseparably connected with the container or with a container housing of the container, but separable from the nebulizer or its housing and from the housing part, so that the indicator device is replaceable together with the container. This allows reuse of the nebulizer and the housing part and preferably of the control device with another container including another indicator device. Thus the overall size of the components to be exchanged is kept small, so that the replacement packages are size reduced, so that transport of a large number of packages is facilitated.

[0028] Preferably, the indicator device is fixedly arranged at a bottom of the container and/or opposite to an outlet of the container. This allows a very compact construction. Further, the indicator device does not interfere with the fluidic connection of the container to the nebulizer or vice versa.

[0029] The indicator device comprises preferably a piercing element for opening and an aeration opening. In particular, this allows a very compact construction and/or supports secure operation.

[0030] Preferably, the indicator device comprises an indicator element and an actuation element for indexing the indicator element. In particular, the indicator element displays an

indication of the number of uses already performed or still possible with the respective container.

[0031] Preferably, a linear movement of the actuation element causes a rotational movement of the indicator element.

[0032] Even more preferably, the actuation element is set in motion by a relative longitudinal movement between the container with the indicator device and the housing and/or housing part of the nebulizer.

[0033] The actuation element in the indicator device is preferably constructed to also block further use of the container in the locked state. In particular, this allows a very compact and simple construction and/or secure operation. Preferably, the number of necessary parts and components can be minimized.

[0034] The actuation element is preferably moveable back and forth between a first and second position for indexing the indicator element and is moveable - at least or only once - into a third position to block further use of the container in the locked state. In particular, this allows a very compact and simple construction and/or secure operation.

[0035] The actuation element is preferably moveable transversally to a longitudinal or dispensing direction of the container or nebulizer. In particular, this allows a very compact and simple construction and/or secure operation.

[0036] Preferably, the indicator device comprises a blocking part which blocks further use of the container and/or nebulizer in the locked state. Alternatively, the blocking part is preferably formed by or made integral with the actuation element. In particular, this allows a very compact and simple construction and/or secure operation.

[0037] The blocking part is preferably moveable transversally to a longitudinal or dispensing direction of the container or nebulizer. In particular, this allows a very compact and simple construction and/or secure operation. Preferably, the number of necessary parts and components can be minimized.

[0038] The blocking part preferably closes an insertion opening of the indicator housing in the locked state. In the unlocked state, the insertion opening is for receiving a driving part attached to the housing, the housing part or the control device of the nebulizer, so that upon a relative movement between the indicator housing and/or the container and the nebulizer housing, the driving part actuates the indicator device such that a use of the nebulizer is counted and/or indicated in the indicator device. In particular, this allows a very compact and simple construction and/or secure operation. Preferably, the number of necessary parts and components can be minimized.

[0039] The blocking part preferably actuates the control device and, thus, a locking device or

its locking element of the nebulizer in the locked state. Thus, further use, in particular further dispensing or nebulization of fluid can be prevented or blocked in the locked state.

[0040] The above aspects of the present invention and the further aspects described below can be realized independently from each other, and in any combination, but the resulting subject-matter is part of the invention only if it falls within the scope of claim 1.

[0041] Further advantages, features, characteristics and aspects of the present invention will become apparent from the claims and the following description of preferred embodiments with reference to the drawings. It shows:

Fig. 1

a schematic section of a known nebulizer in a non-tensioned state;

Fig. 2

a schematic section, rotated 90° compared with Fig. 1, of the known nebulizer in a tensioned state;

Fig. 3

a schematic section of a nebulizer with an inserted container in a non-tensioned state according to a preferred first embodiment of the present invention;

Fig. 4

a partial enlargement of the encircled part of Fig. 3;

Fig. 5

a perspective view of the section of the nebulizer according to Fig. 3;

Fig. 6

an enlargement of the encircled part of Fig. 5;

Fig. 7

a schematic exploded view of an indicator device of a nebulizer according to a preferred embodiment of the present invention;

Fig. 8

an axial section of the indicator device in an actuated state;

Fig. 9

an axial section of the indicator device in a locked state;

Fig. 10

a perspective section of the indicator device in an actuated state;

Fig. 11

a perspective section of the indicator device in an released state;

Fig. 12

a partial enlargement of the nebulizer similar to Fig. 4, but in a partially tensioned state;

Fig. 13

a partial enlargement of the nebulizer similar to Fig. 4, but in a fully tensioned state;

Fig. 14

a partial section of the nebulizer similar to Fig. 4, but in an intermediate state during a dispensing stroke;

Fig. 15

a partial section of the nebulizer similar to Fig. 4, but with an indicator device of the container in a locked state;

Fig. 16

a schematic section of the nebulizer in the locked state after next tensioning with partially opened housing part and with locked locking device;

Fig. 17

a partial enlargement of the encircled part of Fig. 13;

Fig. 18

a schematic section of the nebulizer similar to Fig. 3 with unlocked locking device;

Fig. 19

a schematic section of the indicator device in the initial state according to a modified embodiment;

Fig. 20

a perspective section of the indicator device according to Fig. 19;

Fig. 21

a schematic section of the nebulizer in the non-tensioned state according to a further or second embodiment of the present invention;

Fig. 22

an enlargement of the indicator device and an associated control device in the non-tensioned state according to Fig. 21;

Fig. 23

a perspective view of the control device;

Fig. 24

a perspective, exploded view of the control device;

Fig. 25

a schematic section of the nebulizer according to Fig. 21, but in the tensioned state;

Fig. 26

a partial enlargement of the indicator device and the control device in the non-tensioned state according to Fig. 25;

Fig. 27

a schematic section of the nebulizer according to Fig. 21, but in the locked state;

Fig. 28

a partial enlargement of the encircled part of Fig. 27;

Fig. 29

an enlargement of the indicator device and control device with the indicator device in the locked state and the control device in a partly actuated state (before actuating the locking device); and

Fig. 30

an enlargement of the indicator device and control device in a locked state for blocking the nebulizer according to Fig. 27.

[0042] In the Figures, the same reference numerals are used for identical or similar parts,

resulting preferably in corresponding or comparable properties and advantages, even if the associated description is not repeated.

[0043] Figs. 1 and 2 show a known nebulizer 1 for atomizing a fluid 2, particularly a highly effective pharmaceutical composition, medicament or the like, diagrammatically shown in a non-tensioned state (Fig. 1) and in a tensioned state (Fig. 2). The nebulizer 1 is constructed in particular as a portable inhaler and preferably operates only mechanical and/or without propellant gas.

[0044] When the fluid 2, preferably a liquid, more particularly a pharmaceutical composition, is nebulized, an aerosol 14 (Fig. 1) is formed or dispensed, which can be breathed in or inhaled by a user. Usually the inhaling is done at least once a day, more particularly several times a day, preferably at set intervals, depending on the complaint or illness from which a patient is suffering.

[0045] The nebulizer 1 is provided with or comprises an replaceable, in particular insertable, container 3 containing the fluid 2. The container 3 thus forms a reservoir for the fluid 2, which is to be nebulized. The container 3 contains multiple doses of fluid 2 or active substance in particular sufficient to provide up to 200 dosage units or doses, for example, i.e. to allow up to 200 sprays or applications. A typical container 3, as disclosed in WO 96/06011 A1, holds e.g. a volume of about 2 to 20 ml.

[0046] Further, the number of doses contained in the container 3 and/or the total volume of the fluid 2 contained in the container 3 can vary depending on the fluid 2 or respective medicament and/or depending on the container 3 and/or depending on the necessary medication or the like.

[0047] The container 3 can be replaced or exchanged, wherein the total number of uses of the nebulizer 1 and thus the number of containers 3, which can be used with the same nebulizer 1, is preferably restricted, e.g. to a total number of four or five containers 3. WO 2012/162305 A1 discloses additionally such a restriction to the total numbers of containers 3 which can be used with the same nebulizer 1.

[0048] The container 3 is preferably substantially cylindrical or cartridge-shaped and once the nebulizer 1 has been opened the container 3 can be inserted therein preferably from below and changed if desired. It is preferably of rigid construction, the fluid 2 in particular being held in a collapsible bag 4 in the container 3. In particular, the container 3 comprises a venting opening or hole 23 which is opened before or during first use.

[0049] The nebulizer 1 comprises a delivery mechanism, preferably a pressure generator 5, for conveying and nebulizing the fluid 2, particularly in a preset and optionally in an adjustable dosage amount.

[0050] The nebulizer 1 or pressure generator 5 comprises preferably a holder 6 for releasably

holding the container 3, a drive spring 7 associated to the holder 6, only partly shown, and/or a blocking element 8 preferably in form of or with a button for preferably manual actuation or depressing. The blocking element 8 can catch and block the holder 6 and can be manually operated to release the holder 6 allowing drive spring 7 to expand.

[0051] The nebulizer 1 or pressure generator 5 comprises preferably a conveying element, such as a conveying tube 9, a non-return valve 10, a pressure chamber 11 and/or an nozzle 12 for nebulizing the fluid 2 into a mouthpiece 13.

[0052] The completely inserted container 3 is fixed or held in the nebulizer 1 via the holder 6 such that the conveying element fluidically connects the container 3 to the nebulizer 1 or pressure generator 5. Preferably, the conveying tube 9 penetrates into the container 3.

[0053] The nebulizer 1 or holder 6 is constructed so that the container 3 can be exchanged.

[0054] When the drive spring 7 is axially tensioned in the tensioning process, the holder 6 with the container 3 and the conveying tube 9 are moved downwards in the drawings and fluid 2 is sucked out of the container 3 into the pressure chamber 11 of the pressure generator 5 through the non-return valve 10. In this state, the holder 6 is caught by the blocking element 8 so that the drive spring 7 is kept compressed. Then, the nebulizer 1 is in the tensioned state.

[0055] During the subsequent relaxation in the nebulization process after actuation or pressing of the blocking element 8 the fluid 2 in the pressure chamber 11 is put under pressure as the conveying tube 9 with its now closed non-return valve 10 is moved back in the pressure chamber 11, here in the drawings upwards, by the relaxation or force of the drive spring 7 and now acts as a pressing ram or piston. This pressure forces the fluid 2 through the nozzle 12, whereupon it is nebulized into the aerosol 14, as shown in Fig. 1, and, thus, dispensed.

[0056] Generally, the nebulizer 1 operates with a spring pressure of 5 to 200 MPa, preferably 10 to 100 MPa on the fluid 2, and/or with a volume of fluid 2 delivered per stroke of 10 to 50 μl , preferably 10 to 20 μl , most preferably about 15 μl . The fluid 2 is converted into or nebulized as aerosol 14, the droplets of which have an aerodynamic diameter of up to 20 μm , preferably 3 to 10 μm . Preferably, the generated jet spray has an angle of 20° to 160°, preferably 80° to 100°. These values also apply to the nebulizer 1 according to the teaching of the present invention as particularly preferred values.

[0057] A user or patient (not shown) can inhale the aerosol 14, preferably while an air supply can be sucked into the mouthpiece 13 through at least one optional air supply opening 15.

[0058] The nebulizer 1 comprises a housing 24, and in particular an (upper) housing part 16 and optionally a biasing or inner part 17 preferably which is rotatable relative thereto (Fig. 2) and/or has an upper part 17a and a lower part 17b (Fig. 1).

[0059] The nebulizer 1 or housing 24 comprises preferably a (lower) housing part 18. This part

18 is in particular manually operable, and/or releasable fixed, particularly fitted or held onto the inner part 17, preferably by means of a retaining element 19.

[0060] Preferably, the housing parts 16 and 18 and/or other parts form the housing 24 of the nebulizer 1.

[0061] In order to insert and/or replace the container 3, preferably the housing 24 can be opened and/or the housing part 18 can be detached from the nebulizer 1, inner part 17 or housing 24.

[0062] Generally and preferably, the container 3 can be inserted before the housing 24 is closed and/or before the housing part 18 is connected to the housing 24. The container 3 may be inserted, opened and/or fluidically connected to the delivery mechanism automatically or simultaneously when (completely) connecting the housing part 18 to the housing 24 / nebulizer 1 and/or when (completely) closing the housing 24 / nebulizer 1. Preferably, the container 3 is open or fluidically connected when tensioning the nebulizer 1 for the first time with the current container 3.

[0063] Preferably, the nebulizer 1 or drive spring 7 can be manually activated or tensioned or loaded or charged, in particular by actuation of a charging or grip member, here preferably by rotating housing part 18 or any other component.

[0064] The charging or grip member, preferably the housing part 18, can be actuated, here rotated relative to the upper housing part 16, carrying with it or driving the inner part 17. The inner part 17 acts on a gear or transmission to transform the rotation in an axial movement. As a result the drive spring 7 is tensioned in the axial direction by means of the gear or transmission (not shown) formed between the inner part 17, in particular its upper part 17a, and the holder 6 and acting on the holder 6. During tensioning the container 3 is moved axially downwards until the container 3 assumes an end position as shown in Fig. 2. In this activated or tensioned state the drive spring 7 is under tension and can be caught or held by the blocking element 8. During the nebulizing process the container 3 is moved back into its original position (non-tensioned position or state shown in Fig. 1) by (the force of) the drive spring 7. Thus the container 3 executes a lifting or stroke movement during the tensioning process and during the nebulizing process.

[0065] The housing part 18 preferably forms a cap-like lower housing part and/or fits around or over a lower free end portion of the container 3. As the drive spring 7 is tensioned the container 3 moves with its end portion (further) into the housing part 18 or towards the end face thereof, while an aeration means, such as an axially acting spring 20 arranged in the housing part 18, comes in contact with base 21 of the container 3 and pierces the container 3 or a base seal or foil 50 thereon with a piercing element 22 when the container 3 makes contact with it for the first time, to allow air in or aeration, preferably by opening or piercing venting hole 23. The venting hole 23 allows for pressure compensation inside the container 3 when fluid 2 is drawn from the container 3 during the actuation of the nebulizer 1.

[0066] The nebulizer 1 comprises an indicator device 25, which counts actuations of the nebulizer 1, preferably by detecting its tensioning or the rotation of the inner part 17 relative to the upper part 16 or housing 24. The counter device 25 or an associated locking device 26 locks the nebulizer 1 against (further) actuation or use, e.g. blocks further rotation of the housing part 18 / inner part 17 and, thus, tensioning of the nebulizer 1 or its drive spring 7 and/or blocks actuation of the blocking element 8, in a locked state when a certain number of actuations or operations or discharged doses has been reached or exceeded.

[0067] In the following and with reference to the further figures, a preferred embodiment of the nebulizer 1, container 3, indicator device 25 and/or locking device 26 is described and shown, wherein the nebulizer is according to an embodiment of to the invention, wherein primarily important aspects and differences will be described and the previous aspects, features and explanations apply preferably additionally or correspondingly even without repetition.

[0068] Fig. 3 shows the nebulizer 1 with the container 3 and indicator device 25 according to a first embodiment of the present invention in a schematic section (longitudinal section) in the non-tensioned state with completely closed nebulizer housing 24 and, thus, closed housing part 18, wherein the container 3 including the proposed indicator device 25 are inserted into or received within the nebulizer 1 and housing 24.

[0069] Fig. 4 shows an enlarged partial section of the encircled part of Fig. 3. Fig. 5 shows a perspective view of the section of the nebulizer 1 of Fig. 3. Fig. 6 shows a partial enlargement of the encircled part of Fig. 5.

[0070] The nebulizer 1 has a longitudinal form or axis which corresponds to the axial direction and/or to the main dispensing direction and/or to stroke movement of the container 3 during tensioning and dispensing.

[0071] In the shown non-tensioned state, the nebulizer 1 or its mouthpiece 13 is preferably closed by a mouthpiece cover 27. The mouthpiece cover 27 is preferably pivotable to allow opening of the mouthpiece 13 for using the nebulizer 1.

[0072] The indicator device 25 is directly and/or unreleasably secured or fixed to or connected with the container 3. In particular, the indicator device 25 is associated to a respective container 3. If the container 3 of the nebulizer 1 is replaced, the indicator device 25 is necessarily or positively replaced as well.

[0073] Preferably, the indicator device 25 is fixedly arranged at the bottom or container base 21 of the container 3 and/or opposite to an outlet or head 28 of the container 3.

[0074] In the present embodiment, the indicator device 25 is preferably directly connected to or abuts at an outer case or preferably rigid housing 29 of the container 3.

[0075] Preferably, the indicator device 25 and the container 3 are connected by form-fit and/or snap-fit.

[0076] In particular, the indicator device 25 circumvents and/or grips over a (lower or bottom) edge 30 and/or any other protrusion or the like of the container 3. In the present embodiment, the edge 30 is a little bit wider in diameter so that it protrudes radially over the essentially cylindrical outer form of the side wall of the container 3 / container housing 29.

[0077] The diameter of the indicator device 25 is preferably at least essentially equal to or slightly greater than the diameter of the container 3 or its edge 30. The edge 30 is preferably formed between the side wall and the bottom or base 21 of the container 3 or container housing 29. Preferably, the edge 30 is formed by flanging, bordering, bending or crimping or by any other suitable material-deforming process.

[0078] The indicator device 25 comprises a housing 31 and preferably has an at least essentially cylindrical form.

[0079] The indicator device 25 and its housing 31 is attached to the container 3 or its base 21 or housing 29, preferably with an at least essentially flat and/or axial side.

[0080] The indicator device 25 or its housing 31 comprises preferably a holding or gripping section 32 for connecting the indicator device 25 with the container 3. Preferably, the gripping section 32 circumvents the edge 30 and/or grips around or over the edge 30.

[0081] In the present embodiments, the gripping section 32 is preferably annular and/or grips over the edge 31 at positions distributed over the circumference of the edge 30 or container 3.

[0082] Preferably, the indicator device 25 and the container 3 are connected with each other by a snap-fit or click connection. Preferably, the container 3 and the indicator device 25 are connected with each other by axially snapping one part on the other.

[0083] Preferably, the gripping section 32 is sufficiently elastic in radial direction so that the container 3 can be entered axially with its edge 30. In the present embodiment, the gripping section 32 preferably comprises a respectively inclined insertion face to facilitate insertion of edge 30 into the annular gripping section 32 or between circumferentially distributed gripping sections 32.

[0084] It has to be noted that other constructional solutions are possible for connecting the container 3 or its housing 29 with the indicator device 25 or its housing 31 or vice versa. In particular, the two parts can be connected with each other additionally or alternatively by welding, brazing, gluing, screwing, clamping, hot-pressing, or the like.

[0085] Fig. 7 shows in a schematic, exploded view the indicator device 25 of a nebulizer according to the preferred embodiment of the present invention.

[0086] The indicator or its housing 31 comprises preferably an upper part 33 and a lower part 34.

[0087] Preferably, the upper part 33 holds or forms the gripping setion 32.

[0088] The indicator device 25 comprises preferably an indicator element 35 and an associated actuation element 36 and/or a transmission 40 or gear 41 for indexing the indicator element 35 or for causing the indexing of the indicator element 35.

[0089] The indicator device 25 is for counting and/or indicating a number of uses performed or still possible with the respective or associated container 3. Preferably, the indicator element 35 comprises markings 37, such as one or more symbols, numbers, coloured or shaded areas or the like, for at least roughly indicating the number of uses already performed with or still possible with the respective container 3. In the present embodiment, the indicator element 35 is preferably rotatable and/or comprises a circumferential wall or outer surface with the at least one marking 37.

[0090] The indicator housing 31 comprises preferably a window 31a, in particular in the circumferential wall through the relevant marking 37 is visible for a user or patient, preferably through the housing part 18 which is in particular transparent.

[0091] The actuation element 36 comprises preferably an actuation arm 38 which, intern comprises preferably a free or actuation end 39, for direct or indirect actuation or indexing of the indicator element 35. Indexing means that the indicator element 35 is moved forward in increments or steps.

[0092] Preferred is an indirect actuation or driving so that the actuation element 36 or its arm 38 actuates or drives the indicator element 35 via a transmission 40. In the present embodiment, the transmission 40 results in a reduction and/or is realized as a worm device.

[0093] The indicator device 25 or transmission 40 comprises preferably a gear 41 and/or a worm 42. Most preferably, the worm 42 is directly formed by the gear 41 so that the gear 41 forms a worm gear and preferably comprises radially protruding teeth 43 in which at least one convolution of the worm 42 is formed (compare the horizontal or axial sections of the mounted indicator device 25 shown in Figs. 8 and 9).

[0094] The gear 41 comprises preferably an axle, in particular one or more axle sections 44 which may axially protrude on opposite sides as realized in the present embodiment.

[0095] The actuation element 36 causes a rotation of the gear 41 around an axis preferably perpendicular to the direction of movement of the actuation element 36, the axis preferably being arranged in a horizontal plane identical or parallel to the plane given by the movement of the actuation element 36.

[0096] The gear 41 is rotatably held preferably by the housing 31 or lower housing part 34, preferably by two bearing sections 45 of the lower part 34. Preferably, the bearing sections 45 comprises recesses for rotatably holding the axle sections 44. However, other constructional solutions are possible as well.

[0097] The housing 31 or lower part 34 bears preferably the indicator element 35 such that it can rotate. In the present embodiment, the lower part 34 comprises preferably two bearing portions 46 arranged on opposite radial sides and axially protruding for rotatably bearing the indicator element 35. The actuation element 35 and/or transmission 40 are preferably arranged at least essentially in between the bearing portions 46.

[0098] The indicator device 25 comprises preferably an actuation spring 47, in particular for biasing the actuation element 36 into a preferred direction and/or for driving the indicator element 35

[0099] Fig. 8 shows in a horizontal or axial section the mounted indicator device 25 in an actuated state where the actuation element 36 has been moved or pushed sideways, namely starting from the first position shown in Figs. 3 to 6 towards the left into a second position which is shown in Fig. 8.

[0100] Fig. 9 shows in a similar section as Fig. 8 the indicator device 25 in a locked state where the actuation element 36 is in a locked, third position.

[0101] It can be seen from Figs. 8 and 9 that protrusions 60 of the indicator element 35 (not shown in Figs. 8 and 9) extend axially, wherein always at least one protrusion 60 is caught in the worm 42 so that a worm drive is formed between the gear 41 and the indicator element 35. Thus, any rotation of gear 41 is transformed in a reduced rotation of the indicator element 35. Further, a permanent engagement between the gear 41 and the indicator element 35, more precisely between at least one protrusion 60 and the worm 42, is ensured. However, other constructional solutions or couplings between the gear 41 and the indicator element 35 are possible.

[0102] Fig. 10 shows the mounted indicator device 25 in a perspective section in the initial, first position and state. Fig. 11 shows the indicator device 25 in a similar perspective section, but with released actuation element 36, i.e. just before the locked state is reached.

[0103] Preferably, the transmission 40 or gear 41 forms a worm (helical groove) 42 with at least one convolution, preferably a with about 1.5 or more convolutions, so that always at least one engaging element of the indicator element 35 or of any other transmission component, in particular the inwardly or axially projecting protrusion 60, engages in the worm 42. Thus, rotation of the gear 41 around its preferably transversal axis results in a rotation of the indicator element 35 around its preferably longitudinally oriented rotation axis. However, other constructional solutions are possible as well.

[0104] Preferably, the teeth 43 are relatively long and/or extend radially sufficiently so that the protrusions are securely guided within the convolutions of the worm 42, in between the teeth 43, and that the actuation portion 39 can still move in radial direction between the protrusion 60 engaging into the worm 42 and the gear 41 in order to actuate or rotate the gear 41 in the desired manner. For this purpose, the actuation portion 39 may engage into respectively deep cut outs between the teeth 43 in order to be able to move below the respective projection 60.

[0105] The indicator device 25 comprises preferably a piercing part 48 (compare Fig. 3 to 6).

[0106] The piercing part 48 is arranged within the indicator device 25 or its housing 31.

[0107] The piercing part 48 is preferably axially moveable.

[0108] The piercing part 48 is preferably moveable such that it can protrude towards the container 3 and/or can open an aeration opening, preferably the venting hole 23, of the container 3, in particular by breaking or piercing a foil 50 covering the venting hole 23.

[0109] In the present embodiment, the piecing element 48 comprises preferably an opening end or tip 49 which can open or pierce the foil 50 covering the container base 21, in particular an indentation 51 formed in the container 3 or its base 21.

[0110] Preferably, the indentation 51 comprises a break through which forms the venting hole 23. However, other constructional solutions are possible as well.

[0111] Fig. 12 shows in a partial enlargement similar to Fig. 4 a lower portion of the nebulizer 1 in an intermediate state after partial tensioning. The indicator device 25 is in an actuated state as shown in Fig. 8 (second position).

[0112] The nebulizer 1 or housing part 18 comprises a driving part 52 for driving or actuating the indicator device 25 when using the nebulizer 1, namely for actuating the indicator device 25 in response to any tensioning of the nebulizer 1 and/or any (axial or stroke-like) movement of the container 3.

[0113] Preferably, the driving part 52 is arranged or formed in the housing part 18, in particular on the axial end face or bottom 53 of the housing part 18.

[0114] Preferably, the driving part 52 is arranged centrally and/or extends axially.

[0115] Preferably, the driving part 52 is at least substantially cylindrical and/or pin-like or bolt-like.

[0116] Preferably, the driving part 52 is held by the housing part 18 and/or integrally formed by the housing part 18.

[0117] The movement of the container 3 and, thus, of the indicator device 25 during the tensioning (downward movement in the drawings) and/or during pressurization and dispensing (upward movement in the drawings) and/or one or both of the respective end positions in the non-tensioned state and tensioned state, respectively, can be used for actuating the indicator device 25, i.e. for counting.

[0118] The relative movement of the container 3 and/or indicator device 25 within the nebulizer 1, and more preferred the movement during dispensing, is used for actuating or triggering the indicator device 25 and/or counting.

[0119] When tensioning the nebulizer 1 and/or moving the indicator device 25 downwards, the driving part 52 enters or engages through an insertion opening 54 of the indicator device 25 or its housing 31, in particular axially.

[0120] Preferably, the driving part 52 and the insertion opening 54 are arranged centrally and/or axially aligned.

[0121] In the present embodiment, the driving part 52 actuates the actuation element 36, i.e. moves the actuation element 36 from an initial first position shown in Fig. 3 to 6, to an actuated second position shown in Fig. 9.

[0122] Preferably, the actuation spring 47 biases the actuation element 36 into the first position.

[0123] In the present embodiment, the actuation element 36 is moveable back and forth between the first and second positions for indexing the indicator element 35, in particular for incrementally rotating the gear 41 in one direction to respectively drive the indicator element 35. As any rotation of gear 41 is transformed in a reduced rotation of the indicator element 35, thus every movement of the actuation element 36 from the first to the second position or vice versa results in a movement of the indicator element 35.

[0124] In the present embodiment, the actuation element 36 is moveable transversally, preferably perpendicularly, to the longitudinal or dispensing direction of the container 3 or nebulizer 1 and/or to the stroke movement of the container 3 and/or indicator device 25.

[0125] Preferably, the actuation element 36 is moved from the more central first position radially outwards to the second position, in particular against the force of the associated, preferably helical actuation spring 47 biasing the actuation element 36 in opposite direction.

[0126] In the second position, the actuation element 36 has been moved with its actuation arm 38 or actuation portion 39 out of engagement with gear 41 as indicated in Figs. 8 and 12.

[0127] Fig. 13 shows in a similar enlarged section as Fig. 12 the fully tensioned state.

[0128] In the (fully) tensioned state, the container 3, more precisely the aeration opening or venting hole 23, is opened at least when the nebulizer 1 is tensioned with a container 3 for the first time.

[0129] Preferably, the opening of the container 3 or venting hole 23 for aeration is realized by piercing or breaking, in particular of foil 50.

[0130] The opening or piercing can be effected directly by the driving part 52. Alternatively, the opening or piercing can be effected independently from the driving part 52, e.g. by means of the aeration spring 20 with the piercing element 22 similar to the embodiment shown in Fig. 2. Alternatively, as in the present embodiment, the opening or piercing can be achieved indirectly, preferably via the piercing part 48 which is preferably actuated by the driving part 52.

[0131] Preferably, the piercing part 48 is formed as separate part and/or provided by the indicator device 25 and/or arranged within the indicator device 25.

[0132] In the preferred embodiment, the piercing part 48 is held axially moveable by a support structure 55 of the indicator device 25, housing 31, upper part 32 and/or indicator element 35, as schematically indicated in Figs. 10 and 11.

[0133] Preferably, the piercing part 48 and/or the support structure 55 are a one-piece-construction with a further part of the indicator devices 25, e.g. with the indicator element 35 or with the indicator housing 31, especially with the upper part 33 of the indicator housing 31.

[0134] Preferably, the piercing part 48, support structure 55 and the further part of the indicator device 25 are made of plastic in an injection molding process.

[0135] Preferably, the support structure 55 comprises flexible arms or ribs for holding the piercing part 48 axially moveable.

[0136] Alternatively the piercing part 48 can be constructed as separate, axially moveable part, which is optionally spring biased in the longitudinal or axial direction away from the container 3, so that the piercing tip 49 is retracted from the container 3 in the non-tensioned state.

[0137] It has to be noted that the piercing part 48 or its tip 49 is preferably received within the indicator device 25 or its housing 31, but can protrude outwards in the actuated state.

[0138] The opening or piercing can be repeated each time the nebulizer 1 is tensioned, i.e. each time when the container 3 reaches its end position in the tensioned state.

[0139] The piercing part 48 may be biased into its retracted or initial position shown in Fig. 3 to 6, in particular by a preferably integrally formed biasing arm, spring or the like, preferably by the support structure 55.

[0140] The piercing part 48 may comprise a compensation portion, such as a flexible arm 56, for compensating any tolerances in axial direction. Such tolerances can occur in particular due to variations during production, in particular variations of the length of the container 3 and/or other components, variations of the connections of the container 3 with the indicator device 25, variations of the length of the indicator device 25 or its housing 31, variations of the axial position of the container 3 within the holder 6, and the like. Thus, different distances between the free end of driving part 52 and the counter-face of the piercing part 48 can result. The construction is such that the driving part 52 and the piercing part 48 cooperate in any case such that the desired piercing is ensured.

[0141] The compensation portion allows axial compression - here by radial flexing of arms 56 - when a predetermined axial force is exceeded in order to avoid any damage of the container 3 and/or any other component of the nebulizer 1. Thus, in the preferred embodiment the driving part 52 first moves the piercing part 48 towards the container base 21 into the piercing position and further axial movement of the driving part 52 is compensated by the compensation portion, preferably by the flexible arms 56 being spread radially outwards, giving way to the tip of the driving part 52 for entering a central recess in the piercing part 48 (on the side opposite to the piercing tip 49).

[0142] The piercing part 48 comprises preferably at least one axial channel, in particular one or more axially extending grooves 57 circumferentially distributed around the circumference of tip 49, in order to ensure unblocked aeration or venting even if the piercing part 48 sticks or stays in the foil 50 or piercing position.

[0143] Fig. 14 shows in a similar enlargement as Fig. 4, 12 and 13 an intermediate state of the pressurization or dispensing process, i.e. when the container 3 has been moved partially upwards again. In this state, the driving part 52 has been withdrawn from the indicator device 25 or through the insertion opening 54 partially such that the actuation element 36 starts to return to its initial or first position due to the force of the actuation spring 47. Finally, after sufficient withdrawal of the driving part 52, the actuation element 36 returns into the first position shown in Figs. 3 to 6 when the back movement is completed.

[0144] The back movement of the container 3 and/or of the actuation element 36 actuates the indicator device 25 or gear 41 and is detected and counted.

[0145] In particular, the actuation element 36 or its arm 38 or actuation portion 39 transmits the back movement or movement from the second to the first position to the transmission 40. In particular, this movement causes an incremental rotation of gear 41.

[0146] Thus, in the present embodiment, the movement of the container 3 and/or indicator device 25 within the nebulizer 1 during dispensing is used for actuating or triggering the indicator device 25 and for counting.

[0147] In the present embodiment, the actuation arm 38 or its portion 39 abuts against one

tooth 43 of gear 41 during the back movement and, thus, turns the gear 41 due to the back movement one step further, in the drawings in clockwise direction.

[0148] Preferably, the indicator device 25 comprises a ratchet 58 preventing any counter-rotation of the transmission 40 or gear 41. Into the present embodiment, the ratchet 58 is formed by a flexible arm extending from the housing 31, in particular lower housing part 34, and/or meshing with or engaging into the gear 41 or its teeth 43.

[0149] In the end position, i.e. in the non-tensioned state, the driving part 52 is preferably further or completely retracted from the indicator device 25, the indicator housing 31 and/or insertion opening 54 as shown in Fig. 3 to 6.

[0150] The transmission 40 or gear 41 transforms the actuation, in particular the (backward) movement of the actuation element 36 or its arm 38 / actuating portion 39, into an indexing of the indicator element 35. The transmission ratio or transmission function of the transmission 40 or gear 41 may be designed or constructed such that a reduction or non-linear driving or indexing is achieved. In the present embodiment, the transmission 40 or gear 41 forms preferably a worm drive for achieving a desired reduction.

[0151] The movement of the actuation element 36 - in particular from the first position to the second position - results in that the actuation arm 38 or its actuation portion 39 are moved out of engagement with the gear 41, in particular can be pulled over the next tooth 43. Hereby, the arm 38 is flexed out. The subsequent movement in opposite direction, i.e. the back movement or movement from the second to the first position, results in that the actuation arm 38 or its actuation portion 39 contacts the next tooth 41 and can transmit the at least essential linear movement of the arm 38, more precisely the preferably linear movement of the actuation element 36, into a rotation of the gear 41, more precisely in an indexing of gear 41 by preferably one tooth 43.

[0152] Preferably, the teeth 43 are asymmetrical, i.e. comprise differently inclined shoulders on one side and the other side in order to facilitate and/or ensure the incremental actuation and movement in one rotational direction by the back and forth movement and engagement of the actuation arm 38.

[0153] Preferably, the actuation element 36 is linearly moveable and/or forms a sliding carriage.

[0154] Preferably, the actuation element 36 is supported and/or held moveably by the housing 31, in particular lower part 34 of the housing 31. However, other constructional solutions are possible as well.

[0155] The actuation spring 47 acts preferably between the housing 31 or lower part 34 on one hand and the actuation element 36 on the other hand.

[0156] In the present embodiment, the spring 47 is preferably already compressed and/or biased in the first position and/or biases the actuation element 36 such that it at least partially closes or blocks the insertion opening 54.

[0157] Preferably, the actuation element 36 comprises an inclined gliding surface 59 at its part protecting into or over the insertion opening 32 in the first position. This surface 59 is inclined such that the insertion of the driving part 52, i.e. its axial movement or abutment, is transformed into a transversal or radial movement of the actuation element 36.

[0158] Alternatively or additionally, such a surface 59 can also be formed at the driving part 52 to achieve the desired transformation of the axial movement into a transversal or radial movement by means of an inclined plane.

[0159] Therefore, the actuation or rotation of the transmission 40 or gear 41 is preferably effected by the force of the actuation spring 47 or any other pressure or energy store or spring means. This results in the advantage that no additional force is necessary for driving the indicator device 25 or its indicator element 35. Consequently, the pressurization and dispensing process is not disturbed.

[0160] Further, the triggering of the counting or actuation of the transmission 40 / gear 41 is effected preferably by the pressurization or dispensing process or movement, i.e. during the actual dispensing of fluid 2, i.e. usually during actual use or inhalation.

[0161] The actuation spring 47 biases the actuation element 36 preferably towards closing the insertion opening 54.

[0162] Usually, the movement of the actuation element 36 is restricted so that it does not completely close the insertion opening 54 before the locked state is reached. This limitation is realized in the present embodiment preferably via a control means or portion 62 against which a control part 63 abuts in particular to restrict the back movement of the actuation element 36 at the first position.

[0163] The abutment is shown in particular in Fig. 10. However, other constructional solutions are possible as well.

[0164] After the number of uses of the nebulizer 1 with the container 3 has reached or exceeded a predetermined number of uses as detected or registered by the indicator device 25, a locked state is entered and the nebulizer 1 will be locked against further use with the current container 3 and preferably the container 3 will be locked against further use with the nebulizer 1.

[0165] In particular, the indicator device 25 comprises a blocking part 61 which blocks further use of the container 3 and/or closes or blocks the insertion opening 54 in the locked state as schematically shown in the schematically enlargement of Fig. 15 which shows a similar part as

Fig. 4 and 12 to 14. In this shown state, the container 3 has returned to its non-tensioned position and the driving part 52 has been retracted from the indicator device 25. During the last dispensing or pressurization process, the indicator device 25 has moved the indicator element 35 one step further and detected or registered that the predetermined number of uses has been reached or exceeded and, thus, that the locked state shall be entered.

[0166] In the present embodiment, the indicator element 35 comprises preferably a control portion 62 which releases the actuating element 36 for detection of the locked state which results in locking the nebulizer 1 or current container 3 against further use.

[0167] Preferably, the control portion 62 comprises a cut out or recess which allows or initiates movement of the blocking part 61 into a blocking position. Preferably, the blocking part 61 blocks or closes the insertion opening 54 in the blocking position, i.e. in the locked state. Preferably the control portion 62 is a wall or ridge on the inside of the rotatable indicator element 35.

[0168] Preferably, the blocking part 61 is integrated into the indicator device 25 or its housing 31.

[0169] The blocking part 61 is preferably moveable transversally or perpendicular to the longitudinal or dispensing direction of the container or nebulizer 1 and/or of the direction of stroke movement of the container 3.

[0170] Preferably, the blocking part 61 blocks the actuation or insertion movement of the driving part 52, in particular relative to the indicator device 25 and/or (sufficient) insertion of the driving part 52.

[0171] Preferably, the blocking part 61 is linearly moveable and/or formed by a sliding carriage. However, other constructional solutions are possible as well.

[0172] Preferably, the blocking part 61 is biased into its blocking position, in the present embodiment preferably by actuation spring 47 or any other suitable biasing means.

[0173] Preferably, the blocking part 61 closes or blocks the insertion opening 54 of the indicator device 25 after the last dose of fluid 2 has been dispensed and when the locked state has been entered or detected. This detection is preferably realized in that the blocking part 61 or any associated component, such as control part 63, can pass the control portion 62 in the locked state, most preferably by spring force, in particular by the force of actuation spring 47 or the like, as schematically shown in Fig. 11.

[0174] Preferably, the blocking part 61 is connected with or formed by the actuation element 36 or vice versa. Most preferably, the blocking part 61 forms a wall or side, preferably flat side, of the actuation element 36. However, other constructional solutions are possible as well.

[0175] In the present embodiment, the actuation element 36 can move in the locked state from the first position into the third position, i.e. preferably in the opposite direction than the movement into the second position.

[0176] In the present embodiment, the actuation element 36 can close the insertion opening 54 preferably completely in the third position (blocking position).

[0177] With other words, the blocking position of the blocking part 61 corresponds preferably to the third position of the actuation element 36.

[0178] In the locked state or third position, the actuation element 36 has moved with the actuation arm 38 or its portion 39 further in the actuation direction so that the actuation portion 39 has passed the previous tooth 43 in the rotation direction of gear 41 as indicated in Fig. 15.

[0179] Preferably, the actuation element 36 is constructed to block further use of the container 3 in the locked state or third position (blocking position).

[0180] Preferably, the actuation element 36 is moveable back and forth between the first and second position for indexing the indicator element 35 and is moveable into a third position to block further use of the container 3 in the locked state.

[0181] In particular, the closed indicator device 25 or blocking part 61 results in particular in that the container 3 cannot move inside the closed housing of the nebulizer 1 in the stroke-like fashion as previously described and as required for normal or further use so that normal use is prevented.

[0182] In particular, the locking of the indicator device 25 or insertion opening 54 results in that the nebulizer 1 or housing part 18 is at least partially opened when the nebulizer 1 is tensioned once more or when it is partially tensioned. Fig. 16 shows this state (partially tensioned nebulizer 1 with partially opened housing part 18) in a schematic, longitudinal section of the nebulizer 1. During the tensioning process the container 3 is moving downwardly together with the indicator device 25. Starting from the non-tensioned state (upper position of the container 3), the indicator device 25 abuts soon with its blocking part 61 / actuating element 36 against the member usually actuating the indicator device 25, here the driving part 52, so that a further usual downward movement is not possible.

[0183] In particular, the blocking part 61 restricts the axial moveability of the container 3 in the nebulizer 1 in the locked state, preferably by preventing the driving part 52 from insertion into the indicator device 25 or restricting its insertion in the locked state. Due to the force applied when tensioning the nebulizer 1 and due to the resulting axial force in the movement of the container 3, the housing part 18 will be moved outwards or relative to the nebulizer 1, inner part 17 or upper part 16 together with the container 3 and indicator device 25 during the further tensioning movement in axial direction in the locked state.

[0184] The above common downward movement of container 3, indicator device 25 and housing part 18 is possible due to a respectively constructed fastening of the housing part 18 at the nebulizer 1. In particular, the retaining force is selected or set such that it can be overcome by the downward movement of the container 3.

[0185] In the present embodiment, the retaining element 19 engages with a retaining nose 64 in a respective retaining recess 65 in the housing part 18 or vice versa. Thus, substantially an undercut or indentation can be realized. However, the abutting shoulders which extend at least essentially radially of the nose 64 on one hand and the recess 65 on the other hand are slightly inclined, preferably by about 1° to 5° to the radial plane such that the axial force of the tensioning process can overcome the retaining force provided by the engagement of the nose 64 into the recess 65 so that the retaining element 19 is flexed radially and the retaining engagement is overcome. Consequently, the housing part 18 is moved downwardly as well and, thus, is pushed at least partly from the nebulizer 1 or separated from the upper housing part 16 and/or pushed from the inner part 17. This pushing or axial displacement of the housing part 18 or any other opening of the nebulizer 1 results in that the nebulizer 1 is locked against further use by means of the locking device 26. Therefore, the indicator device 25 or its blocking part 61 effects indirectly via the opening of the nebulizer 1 the desired locking of the nebulizer 1 in the locked state. Preferably, the housing part 18 forms (part of) a mechanical connection or coupling for actuating or controlling the locking device 26.

[0186] However, a (more) direct actuation of the locking, in particular of the locking device 26 is possible as well. The indicator device 25 or its actuation element 36 or blocking part 61 can directly act on or actuate the locking device 26, via a control device 75 which actuates independently from the housing part 18 the locking device 26 for entering the locked state or in the locked state and which is explained later with reference to a second embodiment shown in Fig. 21 to 30.

[0187] The locking device 26 blocks tensioning of the nebulizer 1 in the locked state.

[0188] Preferably, the locking device 26 comprises a moveable locking element 66 and an associated locking spring 67. The locking element 66 is preferably axially moveable between a locked position and an unlocked position. The locking element 66 is preferably biased into the locked position by the locking spring 67.

[0189] In the locked position, the locking element 66 is preferably in its lower axial position shown in Fig. 16. Fig. 17 shows an enlargement of the encircled area of Fig. 16.

[0190] In the locked position, the locking element 66 blocks rotation of the inner part 17 relative to the outer part 16 and, thus, blocks (further) tensioning of the nebulizer 1. This is preferably achieved in the present embodiment in that the locking element 66 moves or engages preferably axially into a respective pocket 68 formed in the upper part 16 such that said relative rotation is blocked. In particular, the locking element 66 engages with an engagement portion 69 into the respective recess or pocket 68 such that any further rotation

and/or back rotation is prevented. However, other constructional solutions are possible as well.

[0191] The locking device 26, in particular the locking element 66 and the locking spring 67, are preferably arranged and/or supported by the inner part 17 and/or extend between the inner part 17 and upper part 16.

[0192] The nebulizer 1, inner part 17 or locking device 26 comprises preferably a cover 70 covering the locking device 26 at least on the periphery of the lower part 17b of the inner part 17 in order to prevent or at least complicate any undesired manipulation of the locking device 26 or locking element 66 by a user or patient.

[0193] Fig. 18 shows the nebulizer 1 in a similar schematic section as Fig. 16, however with the locking device 26 in the unlocked position, i.e. the locking element 66 in the upper position. The locking device 26 or locking element 66 is brought into this position or unlocked preferably only by closing the nebulizer 1, in particular by the housing part 18 in the completely attached or closed position.

[0194] In the shown embodiment, the housing part 18 comprises a preferably finger-like and/or axially extending actuator 71 which extends into the locking device 66 and/or into the cover 70 and/or axially abuts and/or pushes the locking element 66 into its unlocking position (upper position), as shown in Fig. 18. Thus, only the completely closed nebulizer 1 or housing part 18 unlocks the locking device 26 and, thus, unlocks the nebulizer 1.

[0195] The actuator 71 is preferably arranged within the housing part 18 so that any manipulation is not possible or at least complicated.

[0196] When the nebulizer 1 is in the locked state and, preferably when the nebulizer 1 or its housing part 18 has been opened partially by the last tensioning process, any further use of the nebulizer 1 with the container 3 and the indicator device 25 in its locked state is not possible. The locking device 26 locks preferably automatically. Preferably, the locking spring 67 biases the locking element 66 into the locking position, so that upon at least partial opening of the nebulizer 1 or (axial) displacement of its housing part 18, the locking device 26 or its locking element 66 can move and moves into the locking position.

[0197] Preferably, the locking element 66 is moveable (essentially or only) in axial direction.

[0198] After replacement of the current container 3 with its locked indicator device 25 (blocking part 61 in the blocking position) against a new container 3 including a new or reset indicator device 25, the nebulizer 1 or its housing part 18 can be closed completely again. Thus, the nebulizer 1 or its locking device 26 can be or is unlocked again. Preferably, the actuator 71 pushes the locking element 66 back into its unlocking position.

[0199] Thus, the locking device 26 is reset or unlocked again, preferably by (completely) closing the nebulizer 1, its housing 24 or housing part 18, and the nebulizer 1 can be used with

the new container 3 as previously.

[0200] It has to be noted that, in a comparative example not falling within the scope of the invention, the insertion opening 54, which is preferably arranged centrally and/or opens in axial direction and/or allows axial insertion of an actuator element, in particular the driving part 52 in the present embodiment, can also be formed as a recess, groove, indentation or the like and/or can be arranged at any position or location at the indicator device 25 with any orientation.

[0201] In a comparative example not falling within the scope of the invention, the insertion opening 54 or its closing can also be omitted. Instead, the indicator device 25, actuation element 36 or blocking part 61 can more or less directly communicate with or actuate the locking device 26 or, for example, the retaining element 19 or blocking element 8 in order to cause a direct or indirect locking of the nebulizer 1 or container 3 against further use.

[0202] Fig. 19 shows in a schematic section the indicator device 25 of a nebulizer according to a modified embodiment of the present invention. Fig. 20 shows a perspective view of the section according to Fig. 19.

[0203] In the following, only relevant differences are described so that the previous explanations and aspects apply in addition, in particular in the same or similar manner, without repetition.

[0204] In the modified embodiment, the actuation arm 38 and actuation portion 39 do not engage inbetween the worm drive, i.e. between the gear 41 and the engaging protrusions 60 of the driven part, here namely the indicator element 35, but engage with or actuate the gear 41 on another side or the side opposite the worm drive, here preferably in Fig. 19 from below and not from above. In particular, the actuation arm 38 extends more or less in a radial plane and/or more or less in a common plane with the actuation spring 47 and/or blocking part 61 or the sliding carriage part of the actuation element 36.

[0205] Preferably, the actuation arm 38 or portion 39 engages with the gear 41 on the side opposite the container 3 or gripping section 32.

[0206] In the modified embodiment, the indicator device 25 counts when the nebulizer 1 is tensioned, i.e. during the tensioning process and not during the dispensing process as provided in the initial embodiment of the present invention.

[0207] In particular, the actuation element 36 or its arm 38 drives or rotates the transmission 40 or gear 41, when the driving part 52 is inserted into the indicator device 25, its housing 31 or its insertion opening 54, in particular when the actuation element 36 is moved from the first position to the second position and/or when the actuation element 36 is pushed transversally by the driving part 52. In the opposite direction, the actuation arm or its actuation portion 39 passes the next tooth 43 of the gear 41, i.e. does not drive the gear 41.

[0208] In the modified embodiment, the indicator device 25 and counting is not driven by the force of the actuation spring 47 or any other spring or energy store, but by the relative movement of the indicator device 25 within the nebulizer 1 and by the insertion of an actuator element, such as the driving part 52.

[0209] In the modified embodiment, the blocking of the carriage / actuation element 36 / locking part 61 to move into the third or locking position are released during the tensioning when a predetermined number of uses is reached or exceeded. Then, the carriage / actuation element 36 / blocking part 61 abut against the driving part 52 because the counting occurs during the tensioning. When the nebulizer 1 is actuated or when the blocking element 8 is depressed, the nebulizer 1 is triggered and the (last) dose of fluid 2 is nebulized. During this nebulization, the driving part 52 is removed from the indicator device 25 or insertion opening 54 so that the carriage / actuation element 36 / blocking part 61 are free to move into the third or locking position due to the force of the actuation spring 47 or any other spring means.

[0210] During the next tensioning, the nebulizer 1 or its housing 24 or housing part 18 will be partially opened when the driving part 52 abuts against the closed indicator device 25, in particular against the carriage / actuation element 36 / blocking part 61 restricting or closing the insertion opening 54.

[0211] In the previous embodiment, the counting or actuating of the indicator device 25 takes place or occurs when dispensing fluid, i.e. when the driving part 52 is withdrawn from the insertion opening 54. There, the carriage / actuation element 36 / blocking part 61 are released during the last use of the nebulizer 1 or dispensing, i.e. when moving from the second to the first position so that the carriage / actuation element 36 / blocking part 61 can move further directly into the third or unlocking position. Thus, any later dispensing is not possible.

[0212] In both cases, i.e. in the previous embodiment and in the modified embodiment, the indicator device 25 blocks full axial or stroke-moveability of the container 3 within the nebulizer 1 in the locked state and/or causes at least partially opening of the nebulizer housing 24 and/or housing part 18 in the locked state, in particular when the nebulizer 1 is tensioned at least partially for the last time with the current container 3.

[0213] Further, the at least partial opening of the nebulizer 1 or its housing 24 or housing part 18 results in that the nebulizer 1 is blocked, namely cannot be tensioned any further or used any further, with the current container 3.

[0214] Figs. 19 and 20 show the indicator device 26 according to the present invention in the non-actuated or initial state and/or with the actuation element 36 in the first position. The control part 63, which extends preferably upwards and/or in axial direction, abuts against the preferably ring-like control portion 62 which is preferably formed by or at the indicator element 35. Preferably, the control portion 62 has a radial distance to the outer wall of the indicator element 35 so that the control part 63 can move inbetween and that the actuation element 36 is free to move between the first and second positions, while the abutment of the control part

63 against the control portion 62 prevents movement of the actuation element 36 from the first position further towards the third position and/or further to (complete) closing the insertion opening 54.

[0215] Preferably, the protrusions 60 are dent-like and/or are tapered towards its free ends.

[0216] Preferably, the protrusions 60 are formed on or connected with the control portion 62.

[0217] Generally, the insertion opening 54 is provided preferably with a conical surface or edge to facilitate insertion of the driving part 52.

[0218] Preferably, the support structure 55 forms or comprises one or more flexible arms for moveably holding the piercing part 48, preferably in the center of the indicator device 25 or its housing 31 or a respective opening of the housing 31, so that the piercing part 48 is usually held inside the indicator device 25 but can move and in particular protrude outwards and/or towards the container 3 for opening or piercing aeration. However, other constructional solutions are possible.

[0219] Generally, the indicator device 25 and the container 3 form an inseparable assembly or unit, which has to be replaced completely after use, in particular after reaching the locked state. However, it is also possible that the container 3 and indicator device 25 are supplied or offered as a kit which can be assembled by the user or patient.

[0220] Generally, the indicator device 25 cannot be reset after reaching the locked state so that it cannot be reused. However, it is also possible to modify the indicator device 25 such that it can be reset and reused. In this case, the indicator device 25 has to be separated from the present container 3 and connected with a new (unused) container 3. Most preferably, such a container change would automatically reset the indicator device 25.

[0221] Generally, the actuation element 36 or blocking part 61 is moveable preferably linearly, in particular like a sliding carriage. In particular, a sliding carriage is formed.

[0222] Preferably, the sliding carriage forms a base part of the actuation element 36 or blocking part 61.

[0223] Preferably, the sliding carriage, actuation element 36 or blocking part 61 is moveably held by sliding guides 72 on opposite sides, preferably on opposite sides of the insertion opening 54, as schematically shown in Figs. 8 and 9. Preferably, the guides 72 are formed by respective rails or the like of the housing 31 or its lower part 34 which grip over respective edges or base portions 73 of the actuation element 36 or blocking part 61 to form the desired sliding guidance. However, other constructional solutions are possible as well.

[0224] Instead of the preferably linear or sled-like moveable actuation element 36 and/or blocking part 61, any other motion, in particular a radial and/or pivotal movement, is possible,

in particular for partially or completely closing the insertion opening 54.

[0225] Alternatively, the actuation element 36 and/or blocking part 61 can move outwards from the indicator device 25 or its housing 31, preferably transversally and/or at one side of the indicator housing 31 for locking at least one engagement possibility and/or actuating any other component in the locked state or for locking the nebulizer 1 and/or container 3.

[0226] Alternatively or additionally, the actuation element 36 and/or blocking part 61 can engage into or abut against a section or contour of the housing part 18 and/or nebulizer housing 24 or the like in order to restrict or prevent operation or movement in the locked state in order to block further use of the nebulizer 1 and/or container 3 in the locked state.

[0227] The actuation element 36 and/or blocking part 61, in particular also when acting radially, are preferably biased by spring 47 or any other spring means. The spring or spring means can be formed integrally and/or by plastic parts or pieces. Alternatively, a spiral or clock spring or any other spring, such as helical spring 47 or the like, could be used for biasing the actuation element 36 and/or blocking part 61, preferably into the locked state.

[0228] It is also possible that the driving part 52 directly drives or actuates the gear 41. In this case, the driving part 52 is preferably elastically supported by the housing part 18, in particular via a spring means (not shown), in particular for compensating axial tolerances and/or allowing radial or transversal flexing of the driving part 52. Additionally or alternatively, the driving part 52 may be flexible in order to allow transversal flexing for engaging with the gear 41 only in one direction of relative axial movement to the gear 41 to rotate the gear 41 only in one rotational direction.

[0229] The indicator device 25 can comprise any other counting mechanism, in particular as described in WO 2009/037085 A1, page 4, line 19 to page 10, line 13. Such a counting mechanism can also trigger, release or actuate the actuation element 36 and/or blocking part 61. When using this counting mechanism, the rotatable indicator element 35 can also release or control the release of the carriage, actuation element 36 or blocking part 61 in the locked state to move into the third or locking position or close the insertion opening 54.

[0230] It is also possible that the carriage or blocking part 61 is independent from the counting. In particular, the driving part 52 may engage the hub of the counting mechanism shown in WO 2009/037085 A1 or the like and/or drive or actuate the indicator device 25 or counting without actuating the carriage or blocking part 61. In this case, the functions are separated. The carriage and/or blocking part 61 are preferably used only for restricting or closing the insertion opening 54 in the locked state, but not for actuating or driving the indicator device 25 of its counting mechanism or transmission 40 or indicator element 35 or the like.

[0231] The container 3 or indicator device 25 or insertion opening 54 may be provided with an optional protection 74, shown schematically only in Fig. 19, which covers in particular the insertion opening 54 before the first use.

[0232] Preferably, the protection 74 has to be removed before the container 3 and/or indicator device 25 can be inserted into the nebulizer 1 or housing part 18.

[0233] Preferably, the protection 74 extends transversally over the indicator device 25 or its housing 31 and/or over the container 3 and/or has a larger diameter than the indicator device 25 and/or container 3, in particular such that it does not fit into the nebulizer 1 or housing part 18.

[0234] Preferably, the protection 74 can be removed only irreversibly, i.e. cannot be reconnected after removal.

[0235] Preferably, the protection 74 covers or closes the insertion opening 54 and/or the indicator device 25.

[0236] Preferably, the protection 74 is connected to the indicator device 25 or container 3 by form-fit or force-fit and/or by a snap-fit or click-fit.

[0237] In the following, a further or second embodiment of the nebulizer 1 according to the present invention will be explained with reference to Figs. 21 to 30, wherein primarily only new features and aspects are described and the previous explanations apply in particular additionally or correspondingly even if a respective repetition is omitted.

[0238] In the further embodiment, the nebulizer 1 comprises a control device 75 which acts between or couples the indicator device 25 and locking device 26 and which works independently from the housing part 18, in particular does not require or initiate an at least partial opening of the nebulizer 1 for or during actuating the locking device 26. With other words, the nebulizer 1 can be locked against further use with the (current) container 3 by means of the control device 75 without partial detachment or opening of the housing part 18. Thus, the housing of the nebulizer 1 is closed in the locked state and the inside is protected from the ingress of dirt or contamination in the locked state, too.

[0239] In the further embodiment, the control device 75 or any part thereof can provide the function of the driving part 52 and in particular drive or actuate the piercing part 48 as provided in the previous embodiment. Alternatively, the control device 75 could be provided in addition to the driving part 52.

[0240] Fig. 21 shows the nebulizer 1 according to the further embodiment in a schematic section in the non-tensioned state. Fig. 22 shows a partial enlargement thereof, namely the indicator device 25 and control device 75.

[0241] The control device 75 has preferably two different states, namely the initial or non-actuated state which is maintained during the normal use of the nebulizer 1, i.e. during the tensioning and nebulization and in the tensioned and non-tensioned state of the nebulizer 1.

Further, the control device 75 can resume an actuated state when the locking device 26 is actuated or released or the locked state of the nebulizer 1 is to be entered.

[0242] Fig. 23 shows the control device 75 in a perspective view in the initial state. Fig. 24 shows the control device 75 in a perspective, exploded view.

[0243] Preferably, the control device 75 is located at or in the housing part 18. In particular, the housing part 18 is cup-like and the control device 75 is located at least partially within the housing part 18 and preferably at least partially at or near the bottom of housing part 18.

[0244] The control device 75 comprises an actuation member 76 for cooperating or engaging with the indicator device 25 and/or with the locking device 26, in particular its locking element 66.

[0245] The actuation member 76 comprises a driving part 77, a holding part 78 and an actuation part 79.

[0246] The actuation member 76 is held or mounted axially moveable in the housing part 18, in particular by means of respective guiding means such as ribs or noses 80 and/or recesses or notches 81 or the like. This movability results in reducing the force which occurs between the indicator device 25 in its locked state and the driving part 77 when by mechanical coupling the locking device 26 is actuated to enter the locked state. This also results in a robust construction for the driving of the indicator device 25.

[0247] Preferably, the driving part 77 is arranged in the center of the holding part 78 and/or aligned with the container 3 and/or central axis of the nebulizer 1.

[0248] Preferably the driving part 77 is arranged coaxial to the container 3 and/or indicator device 25.

[0249] The driving part 77 protrudes preferably in axial direction from the holding part 78 and/or towards the container 3 or indicator device 25.

[0250] The driving part 77 is preferably tube- or sleeve-like.

[0251] The driving part 77 comprises preferably a central through-opening 82 and/or free end 83.

[0252] Preferably, the holding part 78 is at least essentially plate-like and/or extends transversally to the axial or stroke direction.

[0253] Preferably, the holding part 78 is at least essentially plate-like and/or extends transversally to the axial or stroke direction.

[0254] Preferably, the actuation member 76 or holding part 78 comprises a cut-out 84, and/or one or more engagement portions 85, preferably located at the circumference and/or on opposite sides.

[0255] The actuation part 79 is preferably arm-like and/or extends preferably in axial direction or parallel to the central axis of the nebulizer 1 or the axis of movement of the container 3.

[0256] Preferably, the actuation member 76 or actuation part 79 extends between the container 3 and the outer wall of the nebulizer 1 and/or between the preferably cup-shaped lower housing part 18 and the inner part 17 and/or - at least in the initial state - into the inner part 17.

[0257] Preferably, the control device 75, actuation member 76 or actuation part 79 can form an axial coupling extending from the lower bottom or free end of the indicator device 25 up towards the locking device 26 located in the inner part 17 and/or upper housing part 16 of the nebulizer 1.

[0258] The control device 75 comprises preferably a holding means or device 86 for holding the actuation member 76 or holding part 78 in an upper or initial position corresponding to the initial state of the control device 75.

[0259] Preferably, the holding device 86 is formed by a metal, unitary and/or stamped part.

[0260] Preferably, the holding device 86 comprises at least one holding portion 87 here multiple or four holding portions 87, and/or a spring portion 88, preferably multiple spring portions 88, for holding the and/or biasing the actuation member 76 in the initial state.

[0261] Preferably, the holding portions 87 are arm-like and/or protrude upwards and/or axially from a central portion 89 of the holding device 86.

[0262] Preferably, the holding portions 87 hold - in particular with its free ends - the actuation member 76 or grip over or its holding part 78 in the initial position and/or engage into the engagement portions 85 or the holding part 78.

[0263] Preferably, the holding portions 87 limit the upward movement of the actuation member 76, i.e. form an axial stop.

[0264] One or more spring portions 88 bias the actuation member 76 axially, upwards and/or against the axial stop formed by the holding portions 87 and/or into the initial position.

[0265] In particular, the spring portions 88 abut against the down-face or from below against the actuation member 76 or holding part 78.

[0266] Preferably, the spring portions 88 are biased upwards or in axial direction, in particular

against the actuation member 76 or holding part 78.

[0267] Preferably, the spring portions 88 are at least essentially S-shaped, preferably with large radii, and/or comprise curved free ends to smoothly glide over the surface against which the ends are biased or pressed.

[0268] The spring portions 88 are preferably arm-like and/or are held by the central base portion 89.

[0269] The holding device 86 comprises preferably a control portion 90 for securing the actuation member 76 or holding part 78 preferably in the upper or initial position and/or in a lower or locked position.

[0270] Preferably, the control portion 90 is arm-like and/or held by the central portion 89. Preferably the central portion 89 forms a flat base.

[0271] Preferably, the control portion 90 comprises a securement portion 91, here two securement portions 91, to secure the holding part 78 in the initial position by abutment from below or any other engagement as schematically shown in Fig. 22, 23 and 26.

[0272] The control portion 90 is preferably arm-like and/or held by the base portion 89.

[0273] The control portion 90 extends preferably upwards and/or at least essentially axially.

[0274] Preferably, the control portion 90 comprises or forms a control surface 92 and/or a guiding surface 93. Here, the surfaces 92 and 93 are formed preferably by differently inclined parts of the control portion 90.

[0275] The holding device 86 or central portion 89 is preferably fixed in the housing part 18 of the nebulizer 1, preferably in the axial end and/or adjacent to the bottom of the housing part 18.

[0276] Preferably, the control device 75 or actuation member 76 comprises a control element 94 for controlling the holding device 86, in particular for release the holding or securing in the initial position so that the actuation member 76 can be moved or pushed axially, in particular from the initial position to the locked position.

[0277] In the shown embodiment, the control element 94 comprises preferably a central or shaft portion 95, an end 96 and/or a base 97, as shown in particular in Fig. 24.

[0278] The control element 94 is axially moveable and preferably held by the actuation member 76 or holding part 78, in particular axially moveable received with its shaft portion 95 in the through-opening 82.

[0279] The control element 94 is axially biased into an upper position preferably by an additional spring portion 98, in particular of the holding device 86.

[0280] Preferably, the control element 94 protrudes with its end 96 axially towards the indicator device 25 and/or over the driving part 77 or its free end 83.

[0281] Preferably, the additional spring portion 98 is arm-like and/or held by the central portion 89.

[0282] As already mentioned, the holding device 86 is preferably made of metal as a stamped and bent part. This facilitates to provide biasing or upward forces as required, in particular with two significantly different forces for the spring portions 88 on one hand and the additional spring portion 98 on the other hand.

[0283] The base 97 extends preferably transversely and/or forms an axial stop against further axial (upward) movement so that the control element 94 is held in a defined axial position at the actuation member 76 and/or biased in its protruding position as shown in particular in Figs. 21 to 23.

[0284] Preferably, the end 96 protruding outwards or axially upwards over the driving part 77 is reduced in diameter so that the driving part 77 or its free end 83 can act on the actuation element 36 and/or actuate / drive the indicator device 25 similar to the driving part 52 previously described in detail. This is preferably achieved or supported by a respective inclination of surface 59.

[0285] Further, the piercing part 48 of the indicator device 25 is actuated and/or pushed axially preferably only by axial abutment with the driving part 77 or its free end 83, but without axial abutment on the control element 94. This is preferably achieved or facilitated in that the piercing part 48 is hollow and/or the end 96 of the control element 94 can engage inbetween the flexible arms 56 of the piercing part 48.

[0286] In the shown embodiment, the locking device 26 or its locking element 66 is designed a little bit different than shown in Figs. 16 to 18, but functions in the same manner.

[0287] In the initial state, the control device 75, in particular the actuation member 76 or its actuation part 79 acts or pushes on the locking device 26 or locking element 66 in particular such that it is held in its non-blocking or upper position as shown in Figs. 21 and 25.

[0288] Fig. 25 shows in a similar schematically section as Fig. 21 the nebulizer 1, but in the tensioned state. In this state, the driving part 77 engages or extends into the insertion opening 54 and indicator device 25 as previously described with respect to the first embodiment according to the present invention.

[0289] In the second embodiment, the driving part 77 acts or works preferably similar as the

driving part 52, to drive or actuate the indicator device 25 or its actuation element 36 and preferably to initiate piercing of the container 3 and/or actuation of the piercing part 48.

[0290] After a predetermined number of uses of the nebulizer 1 or current container 3 has been reached or exceeded, the indicator device 25 actuates the locking device 26 by means of the control device 75 or its actuation member 76.

[0291] The control device 75 forms or allows a mechanical coupling between the indicator device 25, which is axially moveable during nebulization and tensioning together with the container 3, and the locking device 26, which is preferably arranged within or at a part of the nebulizer 1, here the upper housing part 16, which is not axially moveable during nebulization and/or tensioning.

[0292] In the locked state or for entering the locked state, the indicator device 25 or its actuation element 36 or its blocking part 61 closes the insertion opening 54. This happens in particular after or when the control device 75 or actuation member 76 or driving part 77 and/or control element 94 have been withdrawn from the indicator device 25 or its housing 31 and/or out from the insertion opening 54, in particular when the container 3 is in its upper axial position as shown in Fig. 21.

[0293] During the next tensioning, the indicator device 25 acts on the control device 75 such that the control device 75 or its actuation member 76 preferably via driving part 77 is moved from the initial position into the locked position shown in Fig. 27.

[0294] The control device 75 couples the indicator device 25 with the locking device 26 such that the indicator device 25 can actuate or initiate actuation of the locking device 26 or can initiate that the locking device 26 enters into the lock state.

[0295] In particular, the control device 75 transmits or transforms the axial movement of the indicator device 25, when the insertion opening 54 has been closed and/or the actuation element 36 has moved into its third or locked position, into an actuation or release of the locking device 26.

[0296] In particular, at least part of the axial movement of the indicator device 25 (together with the container 3) drives or moves the actuation member 76 in axial direction as well.

[0297] In the present embodiment, the actuation member 76 or its actuation part 79 is axially moved away from the locking device 26 or out of the inner part 17 or out of engagement with locking element 66, when the actuation member 76 or actuation part 79 is moved from the initial position into its locked position.

[0298] Then, the locking device 26 or its locking element 66 moves - in particular due to the force of the locking spring 67 or the like - into the locked position and locks the nebulizer 1 against further use (with the current container 3). This situation is shown in Fig. 27 and in the

partial enlargement of the encircled area of Fig. 27 which is shown in Fig. 28. This state is in particular basically similar to the state described with regard to Fig. 16 and 17 so that these explanations apply preferably additionally or correspondingly.

[0299] In the locked state, the locking device 26 or its locking element 66 blocks any (further) rotation of the inner part 17 relative to the upper housing part 16 and, thus, any further tensioning of the nebulizer 1 or drive spring 7. Consequently, the nebulizer 1 could be used only one last time provided that the nebulizer 1 has reached its completed tensioned state, i.e. provided that the locking device 26 has not locked the tensioning before this state has been reached.

[0300] Fig. 29 shows in a schematic enlargement the indicator device 25 and the control device 75 in an intermediate position between the initial state and the actuated state. The indicator device 25 has assumed its locked state, i.e. the insertion opening 54 is closed. The indicator device 25 has moved already axially or downwards partially so that the control element 94 has already been actuated. In particular, the end 96 of the control element 94 or shaft portion 95 protrudes and abuts first against the indicator device 25 or its actuation element 36 or blocking part 61 when the indicator device 25 is moving downwards. Thus, the control element 94 is moved downwards or axially as well and, in particular, relative to the actuation member 76 or driving part 77 or holding device 86 or its control portion 90.

[0301] The control element 94 controls preferably the holding device 86 or its control portion 90.

[0302] Preferably, actuation or axial (downward) movement of the control element 94 initiates release or unblocking of holding device 86 or its control portion 90.

[0303] Preferably, the control element 94 acts with its base 97 on the control portion 90 or its control surface 92 such that downward movement of the control element 94 results in flexing of the control portion 90 radially and/or outwards.

[0304] Preferably, the control element 94 acts with its base 97 on the control portion 90 or its control surface 92 such that downward movement of the control element 94 results in flexing of the control portion 90 so that any axial downward movement of the actuation member 76 is not blocked anymore by the securement portion(s) 91.

[0305] Fig. 29 shows the control element 94 in a partly actuated position, i.e. already pushed downwards, and the control portion 90 in the unblocking position, here flexed outwards and/or moved with its securement portion(s) 91 sideways in alignment with the cut-out 84, so that the actuation member 76 or its holding part 78 is free to be moved axially and/or downwards by the (further) axial movement of the indicator device 25.

[0306] Preferably, the control element 94 is actuated to unblock the control device 75 or to enable the actuation member 76 to be moved from the initial position towards a position at the

lower end of the housing part 18.

[0307] The actuation member 76 is moved from the initial position to a position at the lower end of the housing part 18 by the indicator device 25, namely its stroke-like movement. In particular, the indicator device 25 abuts with its actuation element 36 or blocking part 61 against the free end 83 of the driving part 77 and, thus, moves or pushes - here axially and/or downwards - the actuation member 76 into a state in which the locking device 26 is actuated. It has to be noted that the locking device 26 can be actuated by the actuation member 76 already before the actuation member 76 reaches a (lower) end or fully actuated position. This allows blocking of the nebulizer 1 already during the movement of the container 3 and indicator device 25 downwards before reaching the end position, i.e. before the nebulizer 1 reaches its (fully) tensioned state,

[0308] Fig. 30 shows in a schematic view similar to Fig. 29 the situation when the control device 75 or actuation member 76 has reached a position in which the locking device has been actuated in particular by moving the actuation part 79 out of engagement with the locking device 26 or locking element 66.

[0309] Due to the downwards pushing by the indicator device 25, the actuation member 76 is moved towards the lower (closed) end of housing part 18. This downwards or axial movement of the actuation member 76 may be supported by the control portion 90 or its guiding surface 93. In particular, the control portion 90 flexes back or inwards from the actuation position, in particular shown in Fig. 29, when the actuation member 76 has reached the fully actuated position or the position at the lower end of housing part 18.

[0310] In the partly or fully actuated position, the actuation member 76 or its actuation part 79 is preferably withdrawn or axially moved away from the locking device 26 or its locking element 66 so that the locking device 26 locks directly or automatically, here due locking spring 67 which biases the locking part 66 into the locking position, or, when the next possibility due to rotation of the inner part 17 relative to the upper part 16 occurs, the nebulizer 1 against further use by blocking any further rotation of the inner part 17 relative to the upper part 16 and, thus, any further tensioning of the nebulizer 1.

[0311] As in the first embodiment, the locking device 26 or its locking element 66 can be released or unlocked again for reuse of the nebulizer 1 after replacement of the current container 3 with its indicator device 25 against the new container 3 with a new indicator device 25. The control device 75 is preferably automatically reset or the control device 75 is preferably automatically returned into the initial position upon replacement of the container 3.

[0312] Preferably, the control device 75 can be reused. In this case, the actuation member 76 can be returned into the initial or upper position.

[0313] Preferably, the control device 75 or its actuation member 76 returns into the initial or upper position when opening the nebulizer 1 or detaching the housing part 18 automatically, in

particular due to the at least one spring portion 88. Other constructional solutions are possible as well.

[0314] Alternatively, in a third embodiment (not shown) the control device 75 is locked itself in the locked state as well, i.e. cannot be reused. In this case, the housing part 18 including the control device 75 have to be replaced as well as the container 3 and indicator device 25 when the nebulizer is to be reused with a new or replaced container.

[0315] In the third embodiment, the control device 75 or actuation member 76 is locked in the locked or actuated position against reuse or release. In particular, the actuation member 76 is blocked against returning into the initial position. Thus, it is not possible to unlock the locking device 26 or its locking element 66 for reuse of the nebulizer 1 by means of the already used or locked control device 75. Instead, an unused or new control device 75, in particular together with a new housing part 18, has to be used after replacement of the already used container 3 with its associated indicator device 25, if the nebulizer 1 is to be reused.

[0316] The optional locking of the actuation member 76 in the locked or actuated position is preferably achieved by the control portion 90 or guiding surface 93 or by flexible fingers (not shown) formed on the holding device 86. The fingers may flexing radially outwards by the downwards movement of the actuation member 76 and form an abutment regarding the return movement. For instance, the locking of the actuation member 76 may be achieved or realized by the control portion 90 or its holding surface 93 which holds the actuation member 76 in the locked position or by one or two blocking portions 99 (differently shaped than in Fig. 21-30, for instance without gliding curvatures) of the control portion 90 which block a (complete) axial return of the actuation member 76 into the initial position as shown in Fig. 24 and 30. In particular, the control portion 90 may flex back or inwards from the actuation position, in particular shown in Fig. 29, when the actuation member 76 has reached the locked or actuated position.

[0317] In the third embodiment, the locking device 26 or its locking element 66 can be released or unlocked again for reuse of the nebulizer 1 after replacement of the current container 3 with its indicator device 25 against the new container 3 with a new indicator device 25 and after replacing the control device 75 against a new control device 75 in the initial state.

[0318] As already mentioned, individual features, aspects and/or principles of the embodiments described may also be combined with one another as desired and may be used particularly in the shown nebulizers 1 but also in similar or different nebulizers, but the resulting subject-matter forms part of the invention only if it falls within the scope of claim 1.

[0319] Features of the different embodiments can be combined or exchanged, but the resulting subject-matter forms part of the invention only if it falls within the scope of claim 1.

[0320] Unlike freestanding equipment or the like the proposed nebulizer 1 is preferably designed to be portable and in particular is a mobile hand operated device.

[0321] The proposed solution may, however, be used not only in the nebulizers 1 specifically described here but also in other nebulizers or inhalers, e.g. powder inhalers or so-called metered dose inhalers, but the resulting subject-matter forms part of the invention only if it falls within the scope of claim 1.

[0322] Preferably, the fluid 2 is a liquid, as already mentioned, especially an aqueous pharmaceutical formulation or an ethanolic pharmaceutical formulation. However, it may also be some other pharmaceutical formulation, a suspension or the like.

[0323] According to an alternative embodiment the fluid 2 may also comprise particles or powder. In this case, instead of the expulsion nozzle 12, some other kind of supply device may be provided, especially an expulsion opening (not shown) or a supply channel (not shown) for supplying the fluid to or powder or the like into the mouthpiece 13. The optional air supply opening 15 then serves to supply ambient air preferably in parallel so as to general or allow an airflow with a sufficient volume for breathing in or inhaling through the mouthpiece 13.

[0324] If necessary the fluid 2 may also be atomized by means of a propellant gas.

[0325] Preferred ingredients and/or formulations of the preferably medicinal fluid 2 are listed in particular in WO 2009/115200 A1, preferably on pages 25 to 40, or in EP 2 614 848 A1, paragraphs 0040 to 0087. In particular, these may be aqueous or non-aqueous solutions, mixtures, formulations containing ethanol or free from any solvent, or the like.

List of reference numerals

[0326]

1	nebulizer
2	fluid
3	container
4	bag
5	pressure generator
6	holder
7	drive spring
8	blocking element
9	conveying tube
10	non-return valve
11	pressure chamber
12	nozzle
13	mouthpiece

14	aerosol
15	air supply opening
16	upper housing part
17	inner part
17a	upper part of inner part
17b	lower part of inner part
18	housing part (lower part)
19	retaining element
20	aeration spring
21	container base
22	piercing element
23	venting hole
24	nebulizer housing
25	indicator device
26	locking device
27	mouthpiece cover
28	head
29	container housing
30	container edge
31	indicator housing
31a	window
32	gripping section
33	upper part
34	lower part
35	indicator element
36	actuation element
37	marking
38	actuation arm
39	actuation portion
40	transmission
41	gear
42	worm
43	tooth
44	axle section
45	bearing section
46	bearing portion

47	actuation spring
48	piercing part
49	piercing tip
50	foil
51	indentation
52	driving part
53	bottom
54	insertion opening
55	support structure
56	flexible arm
57	groove
58	ratchet
59	surface
60	protrusion
61	blocking part
62	control portion
63	control part
64	retaining nose
65	retaining recess
66	locking element
67	locking spring
68	pocket
69	engagement portion
70	cover
71	actuator
72	sliding guide
73	base portion
74	protection
75	control device
76	actuation member
77	driving part
78	holding part
79	actuation part
80	nose
81	notch

82	through-opening
83	free end
84	cut-out
85	engagement portion
86	holding device
87	holding portion
88	spring portion
89	central portion
90	control portion
91	securement portion
92	control surface
93	guiding surface
94	control element
95	shaft portion
96	end
97	base
98	additional spring portion
99	blocking portion

REFERENCES CITED IN THE DESCRIPTION

This list of references cited by the applicant is for the reader's convenience only. It does not form part of the European patent document. Even though great care has been taken in compiling the references, errors or omissions cannot be excluded and the EPO disclaims all liability in this regard.

Patent documents cited in the description

- [WO2012162305A1 \[0002\] \[0003\] \[0004\] \[0047\]](#)
- [WO201216305A1 \[0005\]](#)
- [US7823584B2 \[0006\]](#)
- [WO2007104694A1 \[0007\]](#)
- [US2003100867A1 \[0008\]](#)
- [WO0103851A1 \[0008\]](#)
- [WO9639337A1 \[0008\]](#)

- [WO2012160047A2 \[0008\]](#)
- [WO9606011A1 \[0045\]](#)
- [WO2009037085A1 \[0229\] \[0230\]](#)
- [WO2009115200A1 \[0325\]](#)
- [EP2614848A1 \[0325\]](#)

P A T E N T K R A V

1. Forstøver (1) som er konfigureret til at forstøve et fluid (2),
hvilken forstøver (1) har en akse som definerer en aksial retning af forstøveren (1),
hvilken forstøver (1) omfatter:
- 5 en udskiftelig beholder (3) som indeholder fluidet (2) som skal forstøves af forstøve-
ren (1);
en indikatorindretning (25) omfattende: et indikatorhus (31) som er fastgjort til be-
holderen; og en tællemekanisme; og
et forstøverhus (24) som er konfigureret således at, i brug, er den udskiftelige be-
10 holder og indikatorindretningen modtaget inden i forstøverhuset (24);
hvor, når beholderen og indikatorindretningen er modtaget inden i forstøverhuset
(24), er forstøveren (1) konfigureret til at forstøve doser af fluidet i beholderen i en serie
af forstøvningsprocesser i hver af hvilke forstøveren begynder i en spændt tilstand og slut-
ter i en ikke-spændt tilstand,
- 15 hvor i løbet af spændingsprocesser af forstøveren (1) i hvilke forstøveren begynder
fra den ikke-spændte tilstand og slutter i den spændte tilstand, flyttes beholderen (3) ak-
sialt inden i forstøverhuset (24) sammen med indikatorindretningen i en første retning,
hvor i løbet af hver forstøvningsproces bevæges beholderen (3) aksialt inden i for-
støverhuset (24) sammen med indikatorindretningen i en anden retning som er modsat til
20 den første retning,
hvor tællemekanismen af indikatorindretningen er konfigureret til at tælle et antal af
forstøvninger eller spændinger af forstøveren (1) med beholderen (3);
hvor forstøveren (1) yderligere omfatter:
en låseindretning (26) som er indrettet til at blive aktueret for at blokere yderligere
25 spænding af forstøveren (1) med beholderen (3) således at forstøveren indtræder i en låst
tilstand i hvilken forstøveren er blokeret for yderligere brug med beholderen (3);
og
en styreindretning (75) som er konfigureret til at koble indikatorindretningen og lå-
seindretningen mekanisk,
- 30 hvor:
forstøveren er struktureret således at, når antallet af forstøvninger eller spændinger
som er talt af tællemekanismen af indikatorindretningen, når eller overskrider et forudbe-
stemt antal af forstøvninger eller spændinger af forstøveren (1) med beholderen (3), styrer
indikatorindretningen (25) låseindretningen (26) mekanisk ved hjælp af styreindretningen
35 (75) således at låseindretningen (26) forårsager at forstøveren (1) indtræder i den låste
tilstand;
og
forstøveren (1) omfatter en drivdel (52, 77) som er en del af styreindretningen (75),
hvor forstøveren er struktureret således at drivdelen er konfigureret til at komme ind i

indikatorhuset (31) for at aktuere tællemekanismen af indikatorindretningen (25) ved den relative bevægelse af beholderen sammen med indikatorindretningen inden i forstøverhuset (24) i løbet af forstøvning eller spænding mens forstøveren ikke er i den låste tilstand, således at en forstøvning eller spænding af forstøveren (1) tælles af tællemekanismen af indikatorindretningen (25).

2. Forstøver ifølge krav 1, hvor forstøveren (1) omfatter en husdel (18) som er aftagelig for at udskifte beholderen (3).

3. Forstøver ifølge krav 2, hvor styreindretningen (75), indbefattende drivdelen, er arrangeret i husdelen (18).

4. Forstøver ifølge et hvilket som helst af de foregående krav, hvor styreindretningen (75) omfatter et aksialt bevægeligt aktueringselement (76) i hvilket drivdelen er omfattet.

15

5. Forstøver ifølge krav 4, hvor styreindretningen (75) omfatter en holdeindretning (86) som er konfigureret til at holde aktueringselementet (76) af styreindretningen (75) i en indledende position, svarende til en indledende tilstand af styreindretningen, i løbet af forstøvning og spænding mens forstøveren ikke indtræder i den låste tilstand.

20

6. Forstøver ifølge krav 5, hvor holdeindretningen omfatter en fortrinsvis radialt fleksibel styredel (90) som er konfigureret til at holde aktueringselementet (76) i den indledende position.

7. Forstøver ifølge krav 5 eller 6, hvor styreindretningen (75) omfatter et styreelement (94) som er konfigureret til, når forstøveren indtræder i den låste tilstand, at styre holdeindretningen til at frigøre holdet på aktueringselementet i den indledende position for således at tillade aktueringselementet (76) at blive bevæget fra den indledende position til en aktueret position.

30

8. Forstøver ifølge krav 7, hvor forstøveren er struktureret således at styreindretningen (75) automatisk vender tilbage fra den aktuerede tilstand til sin indledende tilstand, fortrinsvis ved hjælp af mindst én fjederdel (88) af holdeindretningen, ved udskiftning af beholderen (3) og indikatorindretningen (25) efter forstøveren er indtrådt i den låste tilstand.

35

9. Forstøver ifølge et hvilket som helst af de foregående krav, hvor styreindretningen (75) omfatter en fortrinsvis stift-lignende aktueringsdel (79) som er konfigureret til at virke på eller styre låseindretningen (26).

10. Forstøver ifølge et hvilket som helst af de foregående krav, hvor forstøveren er struktureret således at, når antallet af forstøvninger eller spændinger som er talt af tællemekanismen af indikatorindretningen, når eller overskrider det forudbestemte antal af forstøvninger eller spændinger af forstøveren (1) med beholderen (3), drives eller aktueres styreindretningen (75), ved mindst en del af den aksiale bevægelse af indikatorindretningen (25) i løbet af forstøvning eller spænding, til at aktuere låseindretningen (26) for at indlede blokering af forstøveren (1) mod spænding.
- 10 11. Forstøver ifølge et hvilket som helst af de foregående krav, hvor indikatorhuset (31) omfatter en indføringsåbning (54) og hvor drivdelen (52, 77) er konfigureret til at komme ind i indikatorhuset (31) gennem indføringsåbningen (54) af indikatorhuset (31) for at aktuere tællemekanismen af indikatorindretningen (25).
- 15 12. Forstøver ifølge krav 11, hvor indikatorindretningen (25) omfatter en blokeringsdel (61), hvor indikatorindretningen (25) er struktureret således at blokeringsdelen lukker eller blokerer indføringsåbningen (54) og derved blokerer for at drivdelen (52, 77) kommer ind i huset af indikatorindretningen (25), når antallet af forstøvninger eller spændinger som er talt af tællemekanismen af indikatorindretningen, når eller overskrider det forudbestemte antal af forstøvninger eller spændinger af forstøveren (1) med beholderen (3).
- 20

DRAWINGS

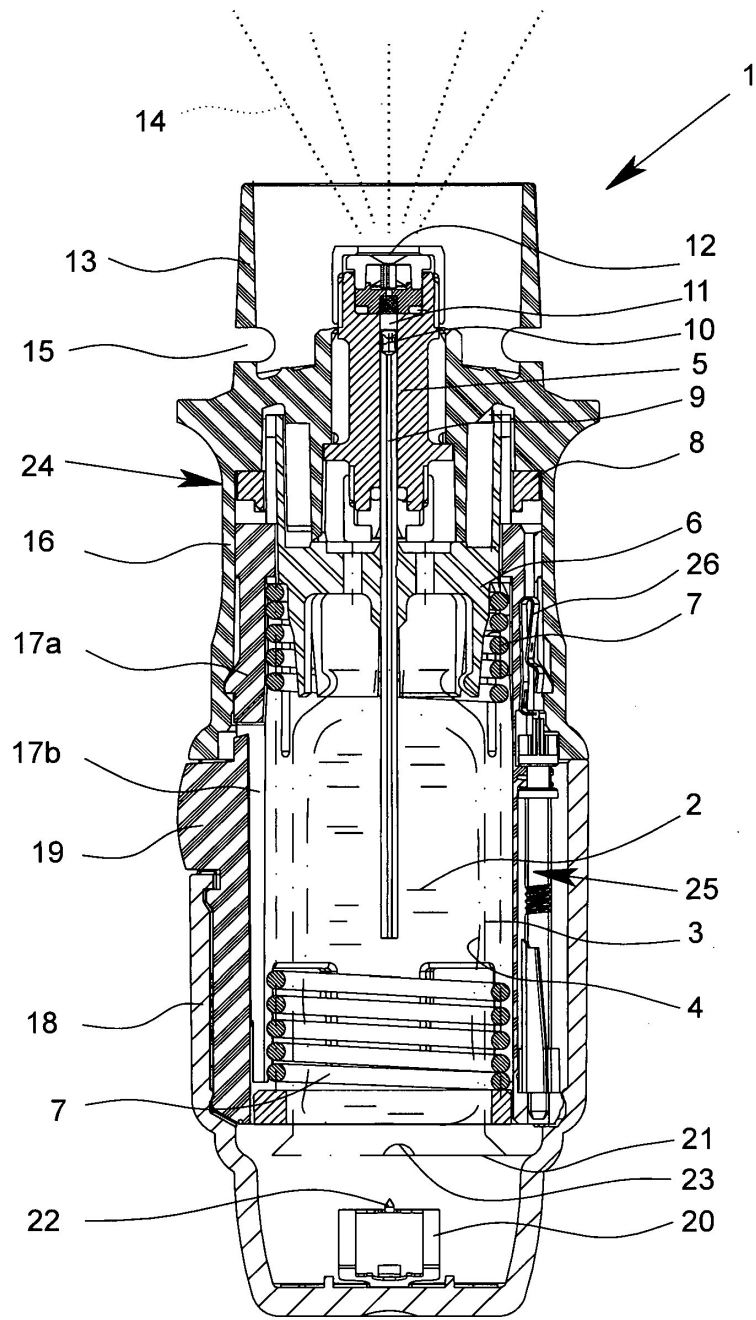

Fig. 1

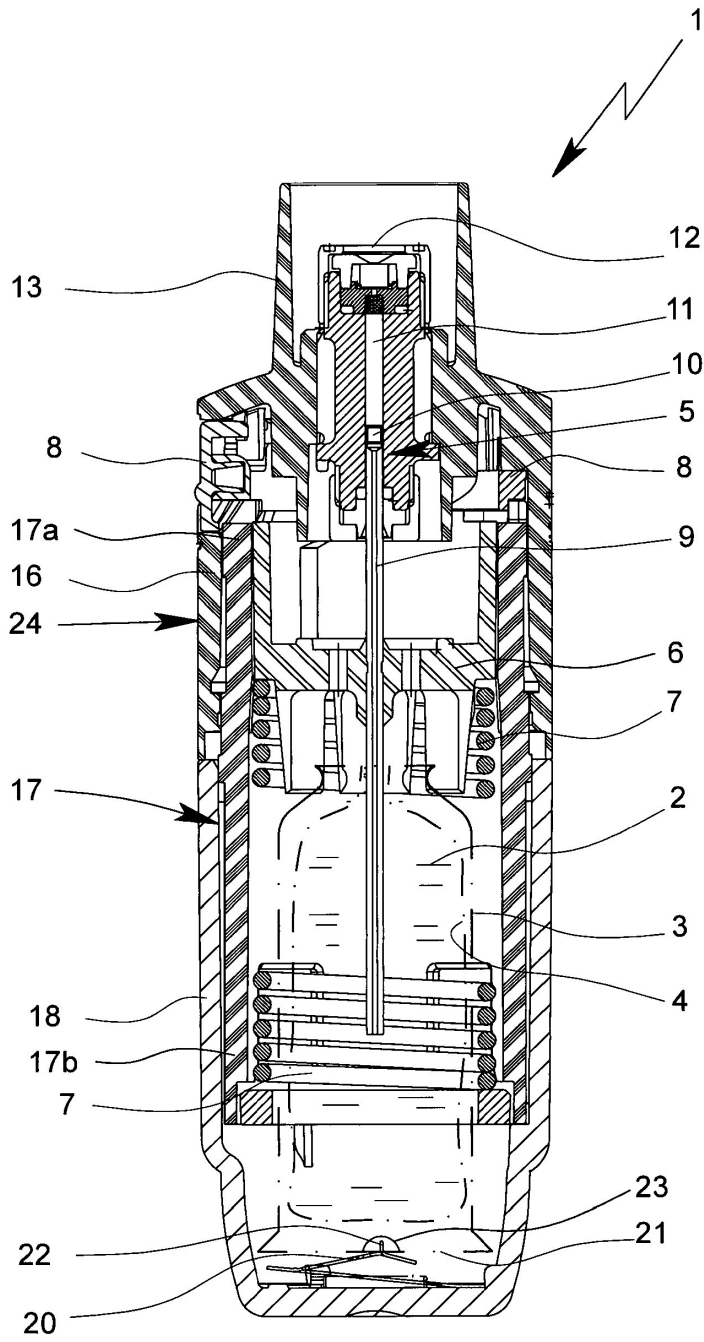

Fig. 2

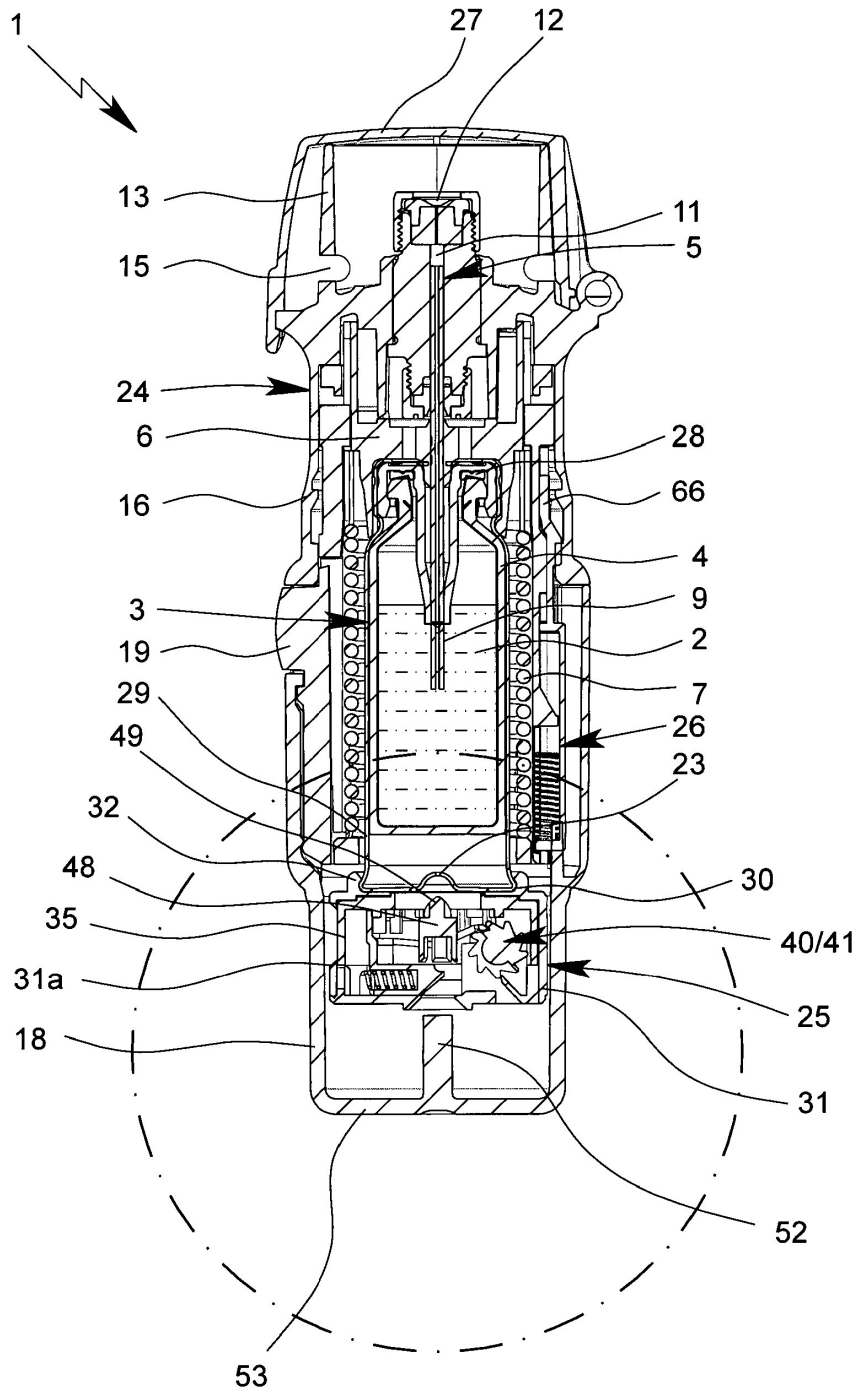

Fig. 3

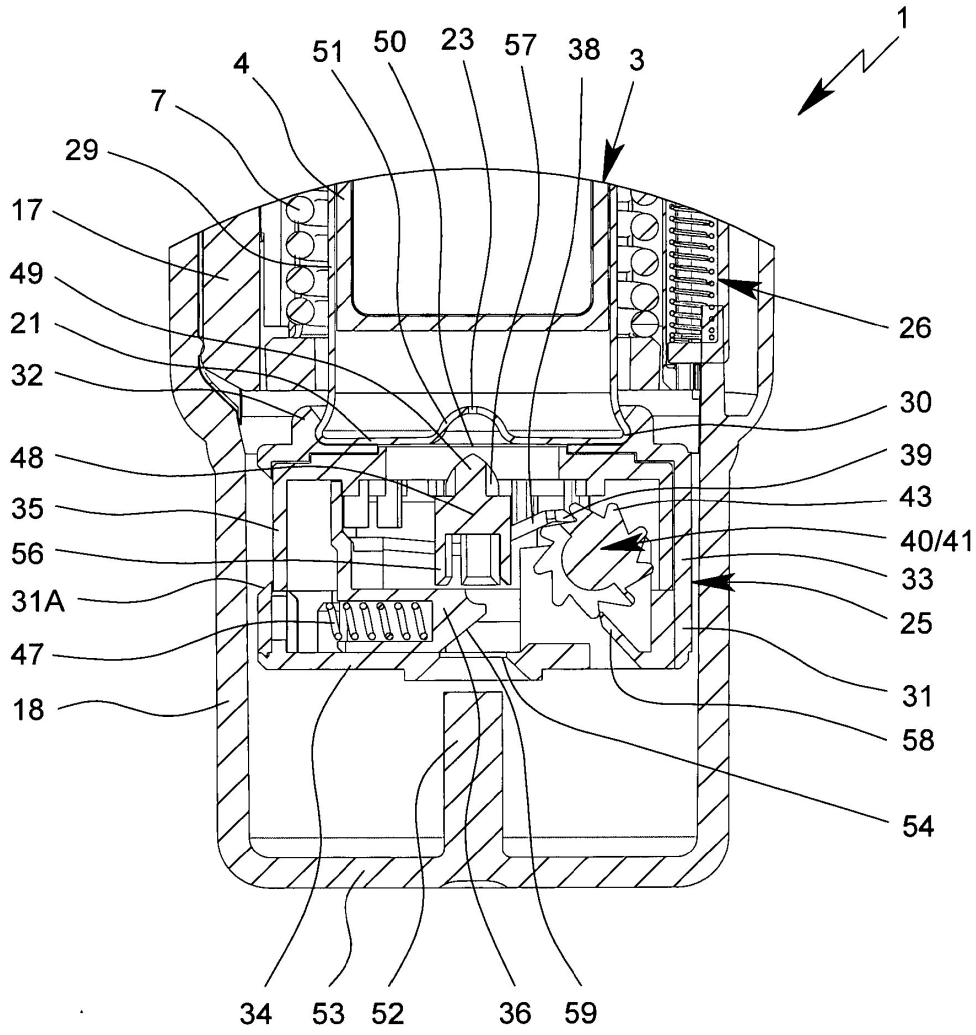

Fig. 4

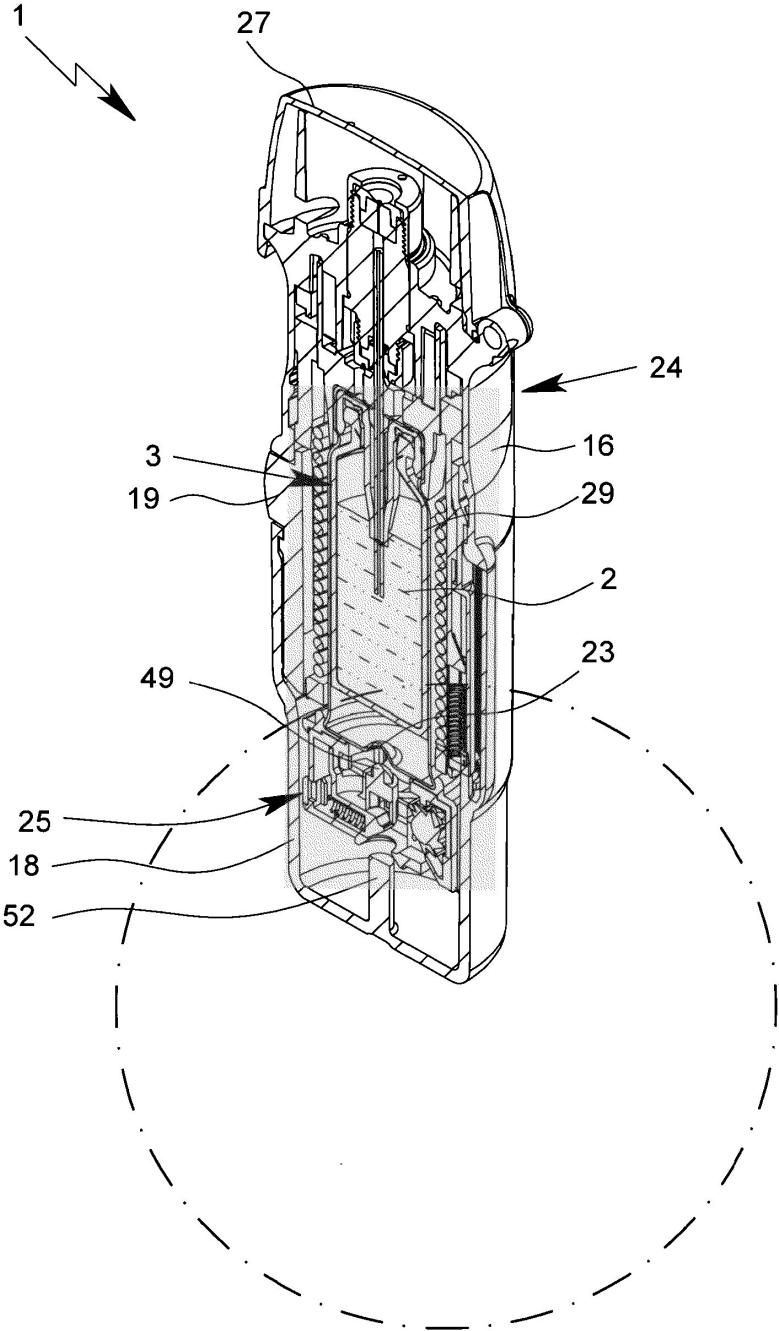

Fig. 5

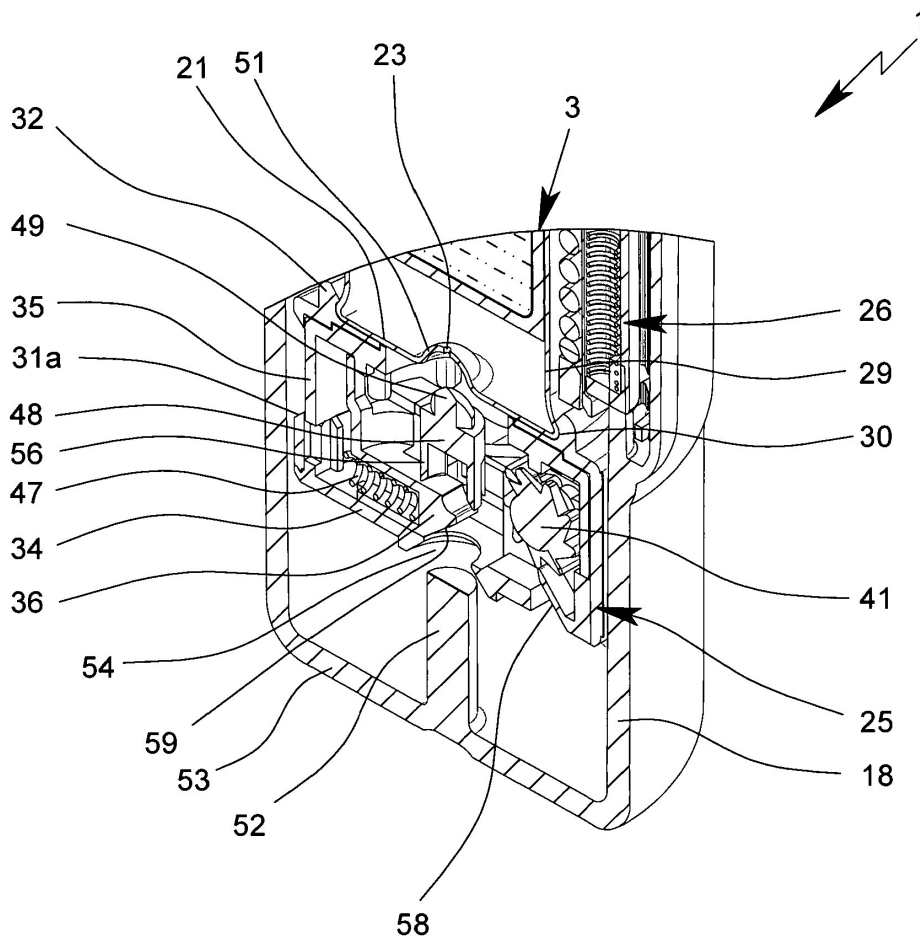

Fig. 6

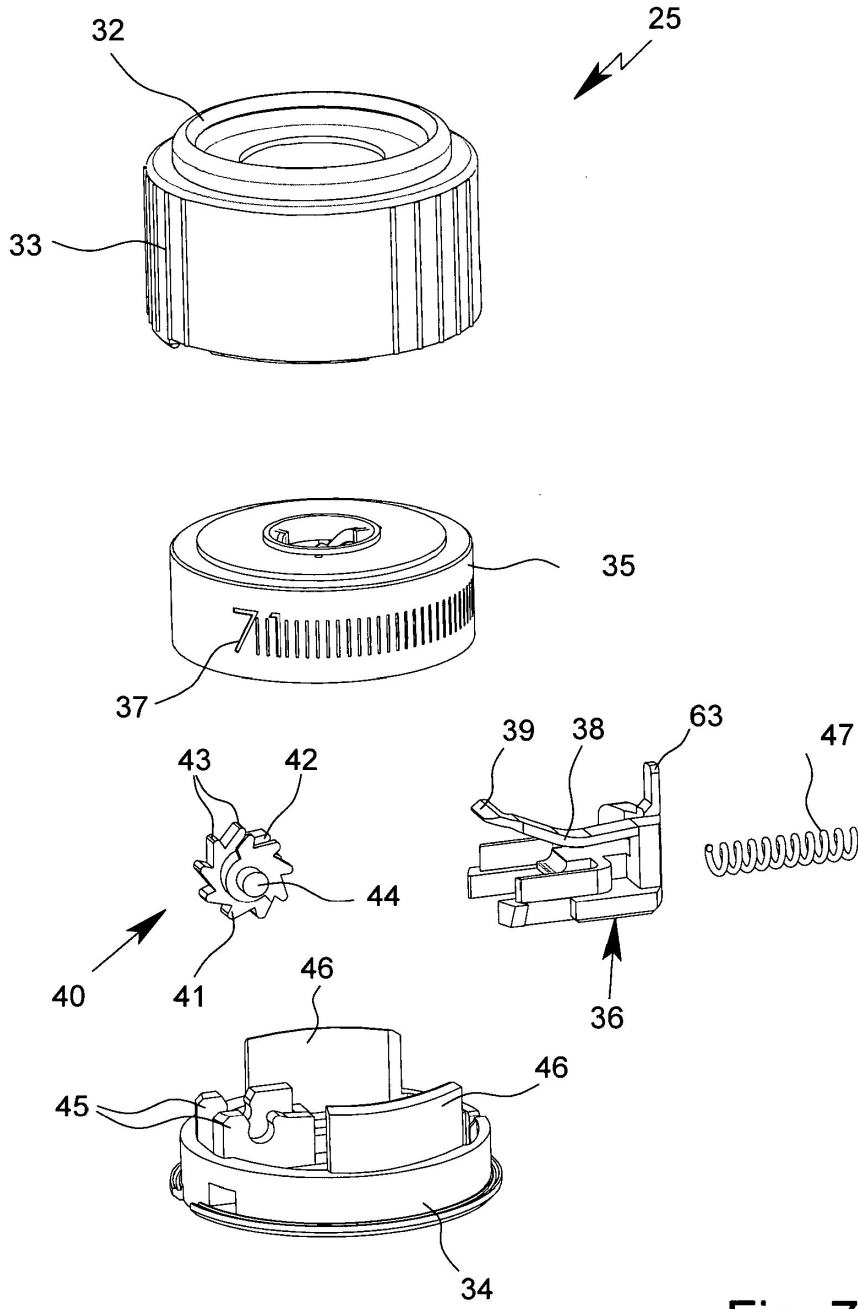

Fig. 7

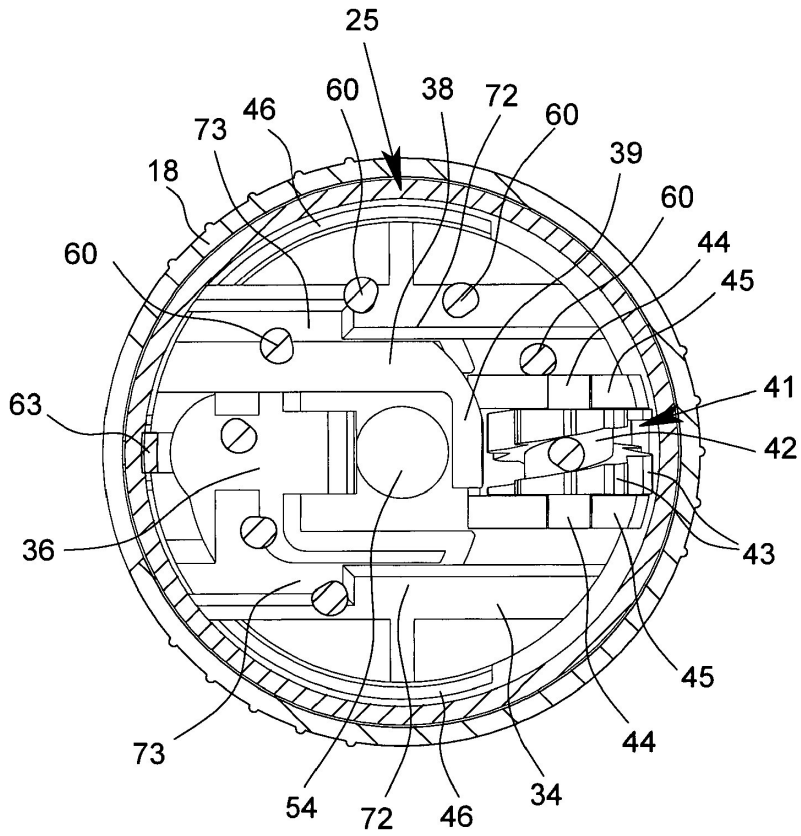

Fig. 8

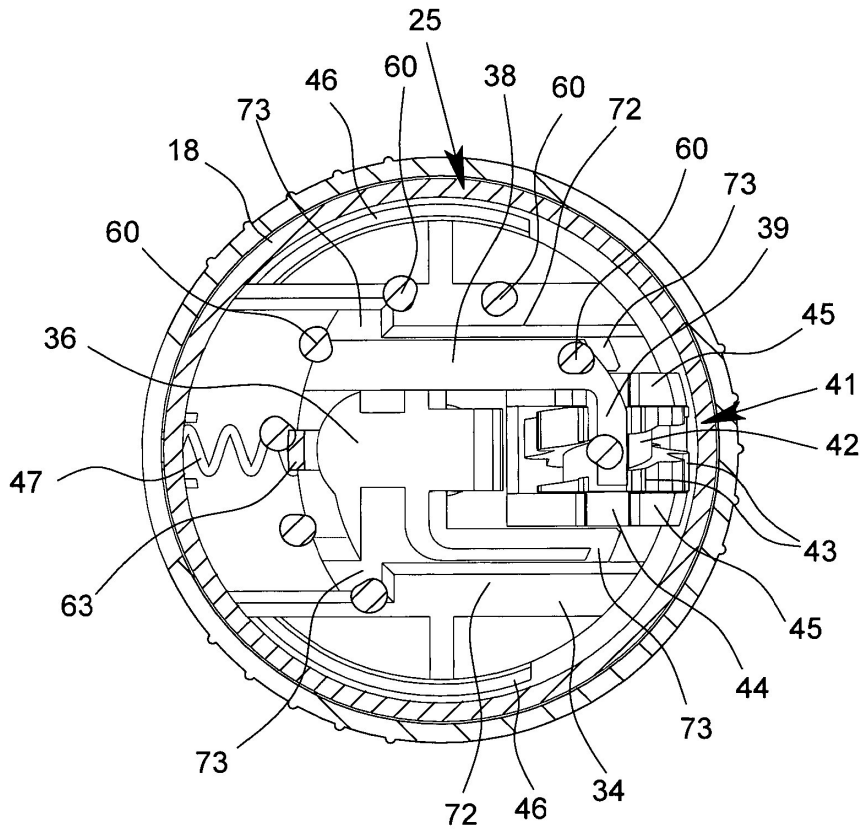

Fig. 9

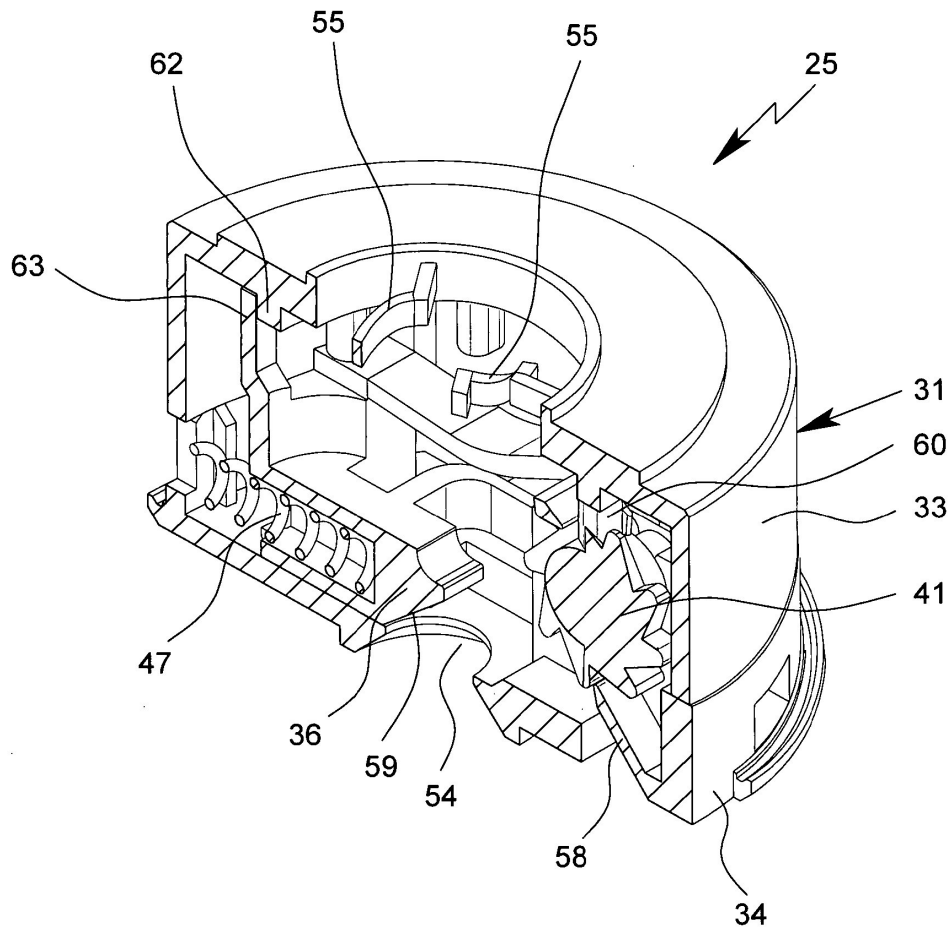

Fig. 10

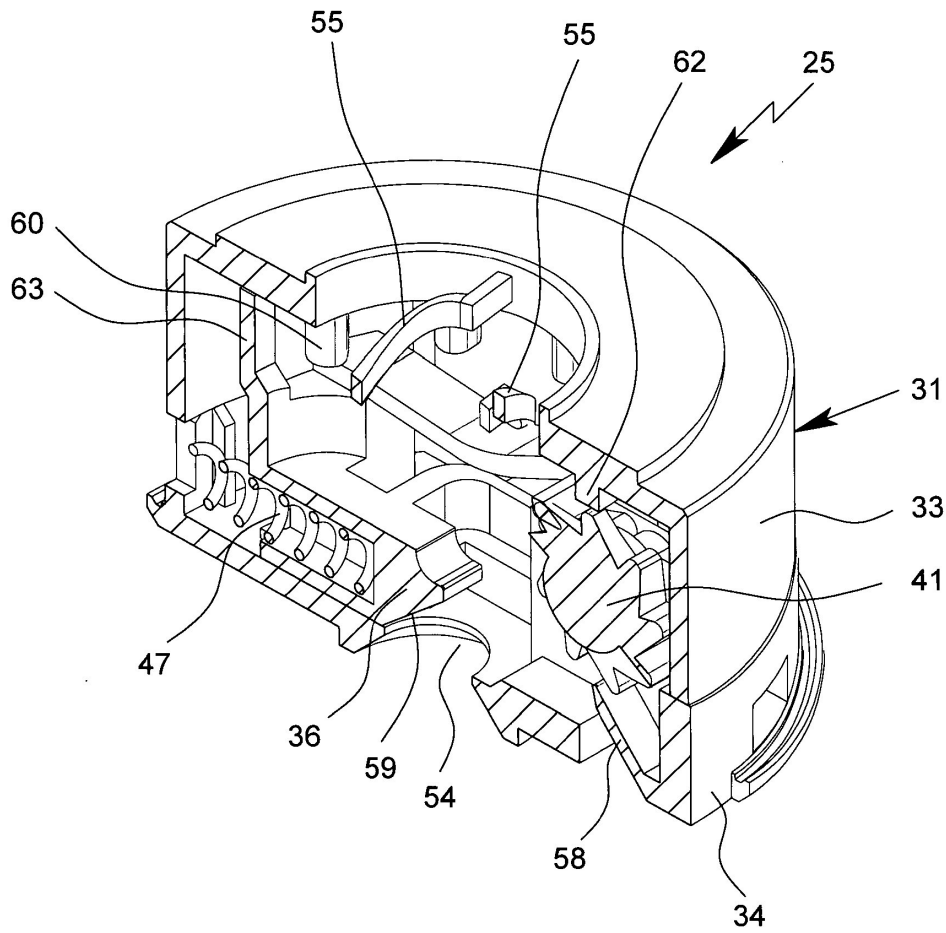

Fig. 11

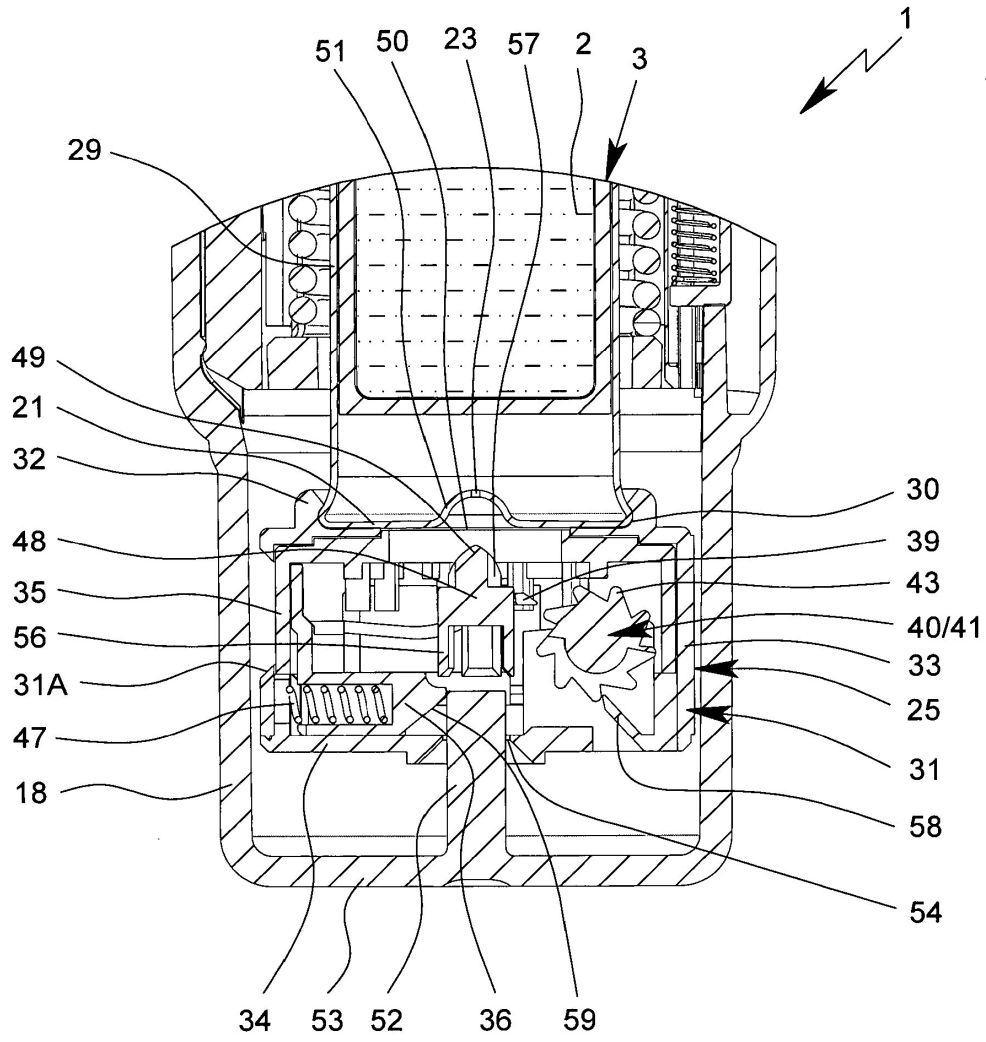

Fig. 12

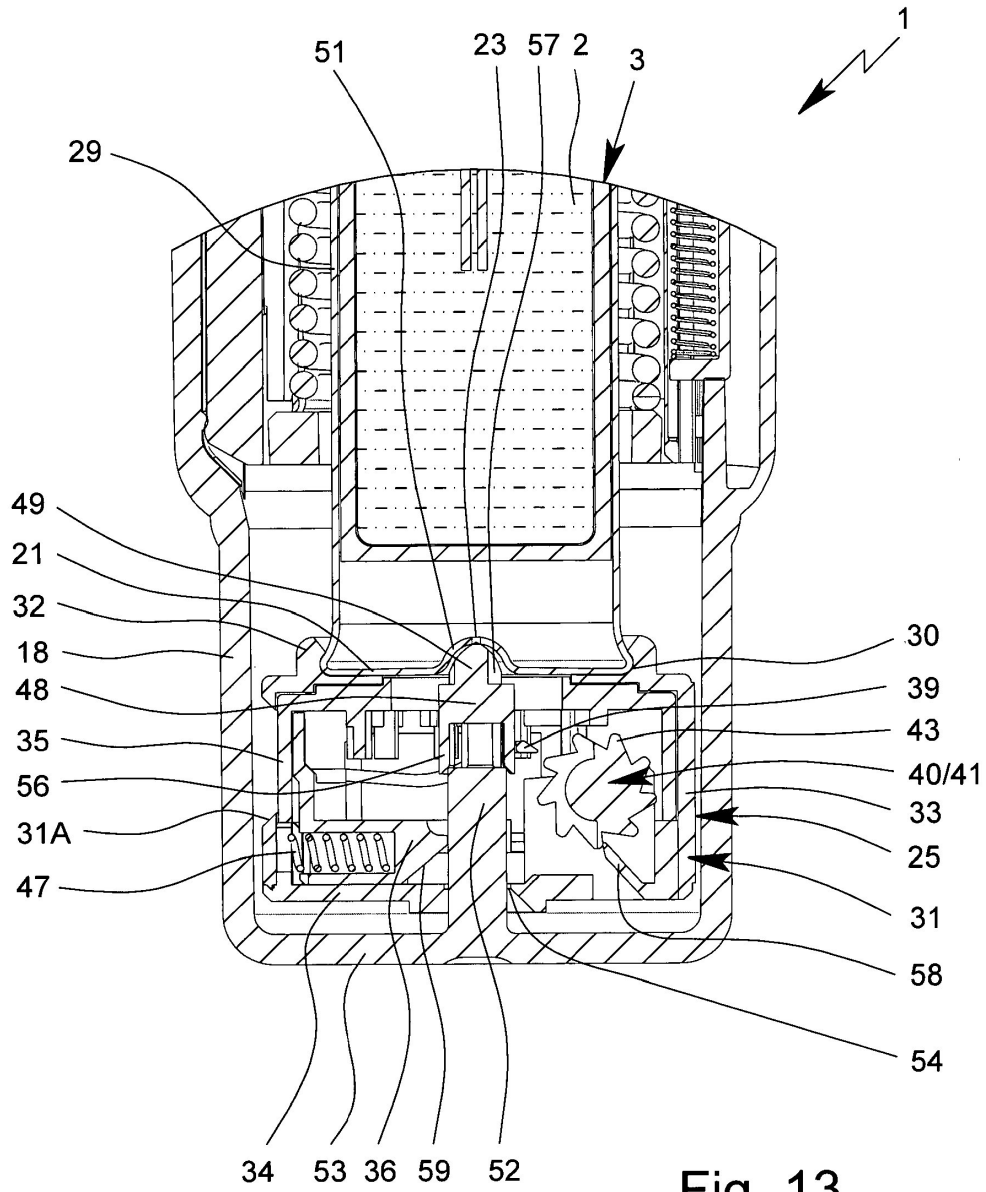

Fig. 13

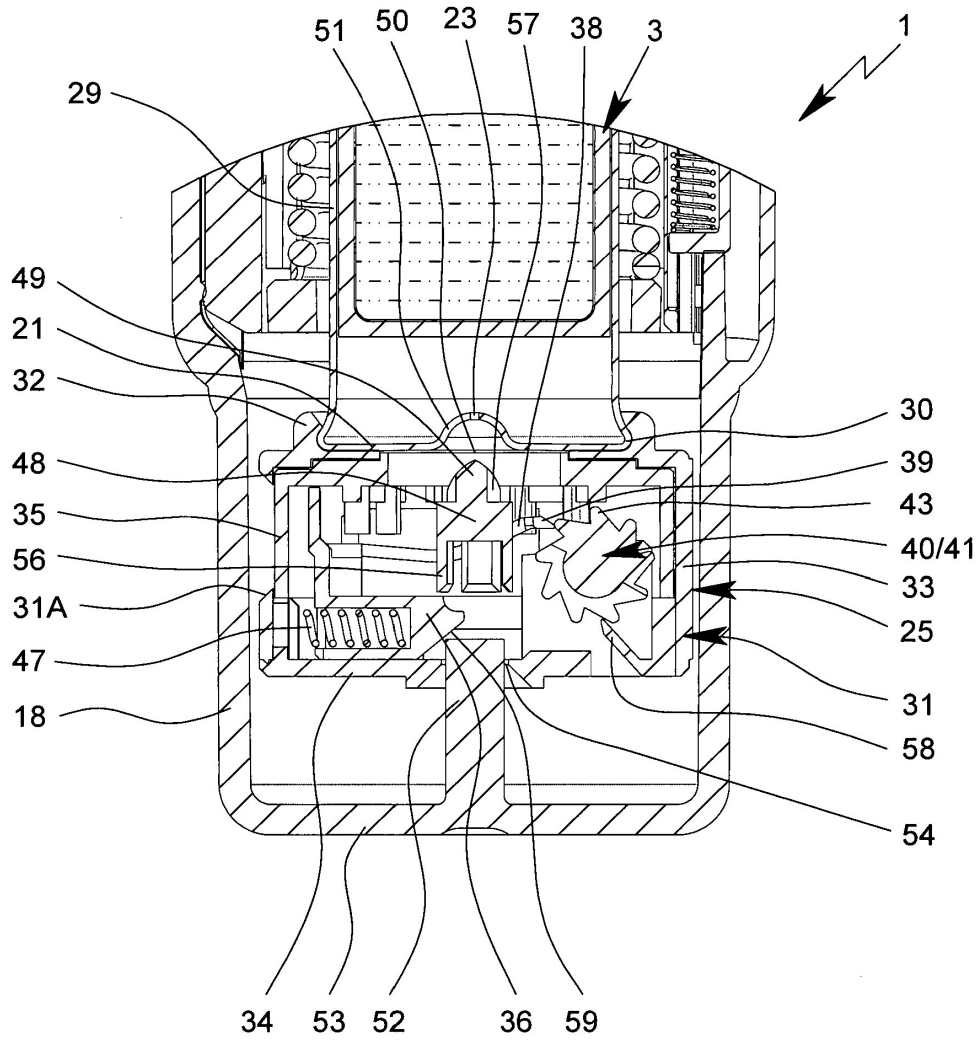

Fig. 14

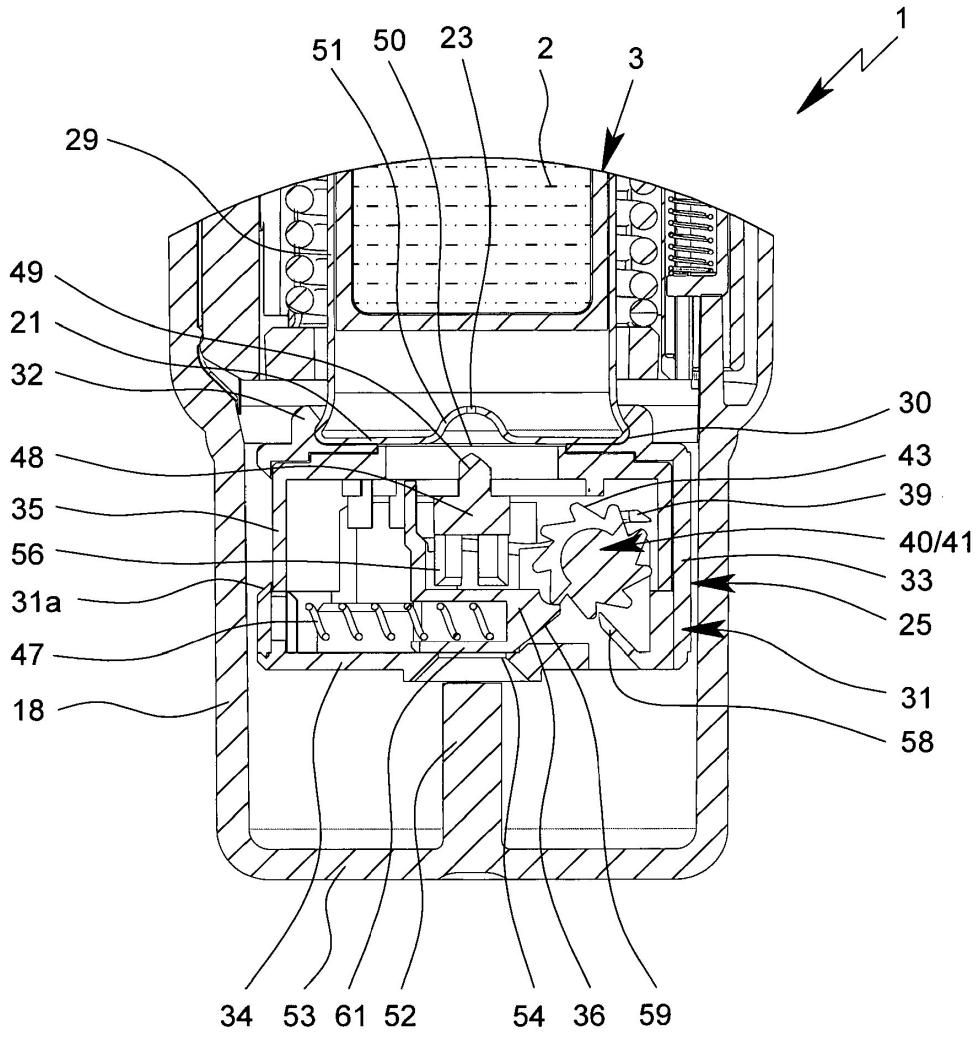

Fig. 15

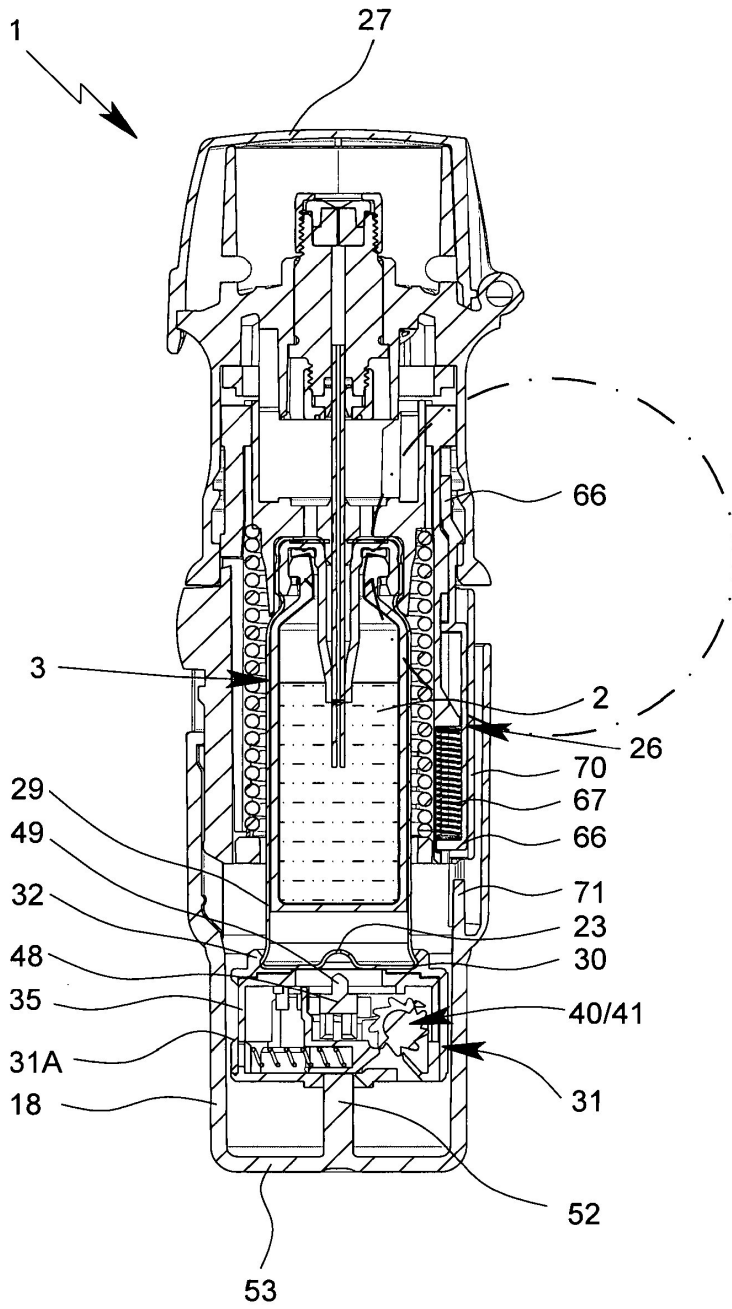

Fig. 16

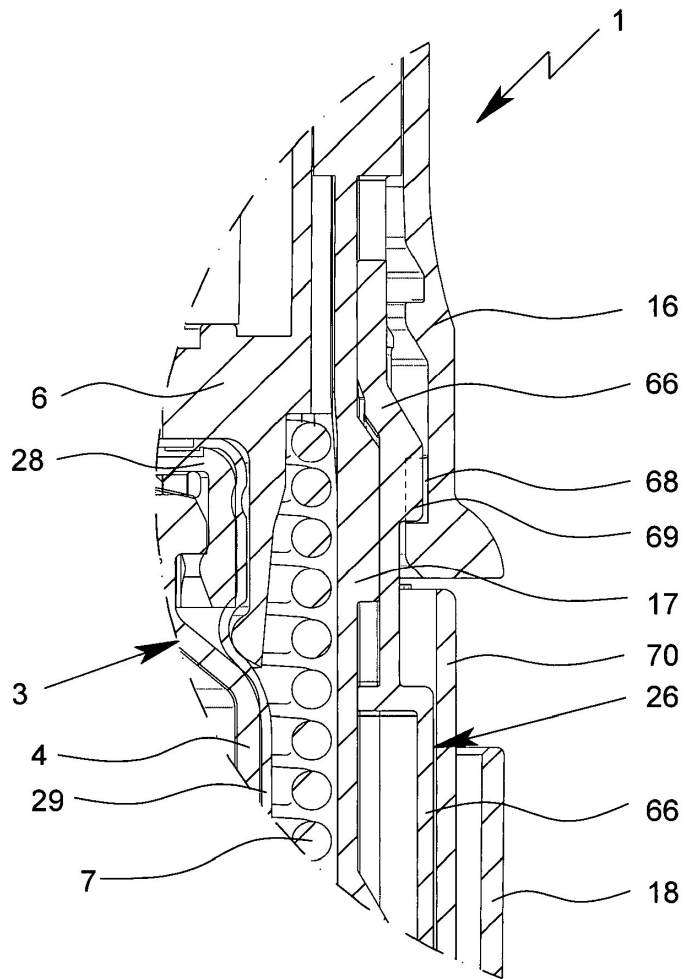

Fig. 17

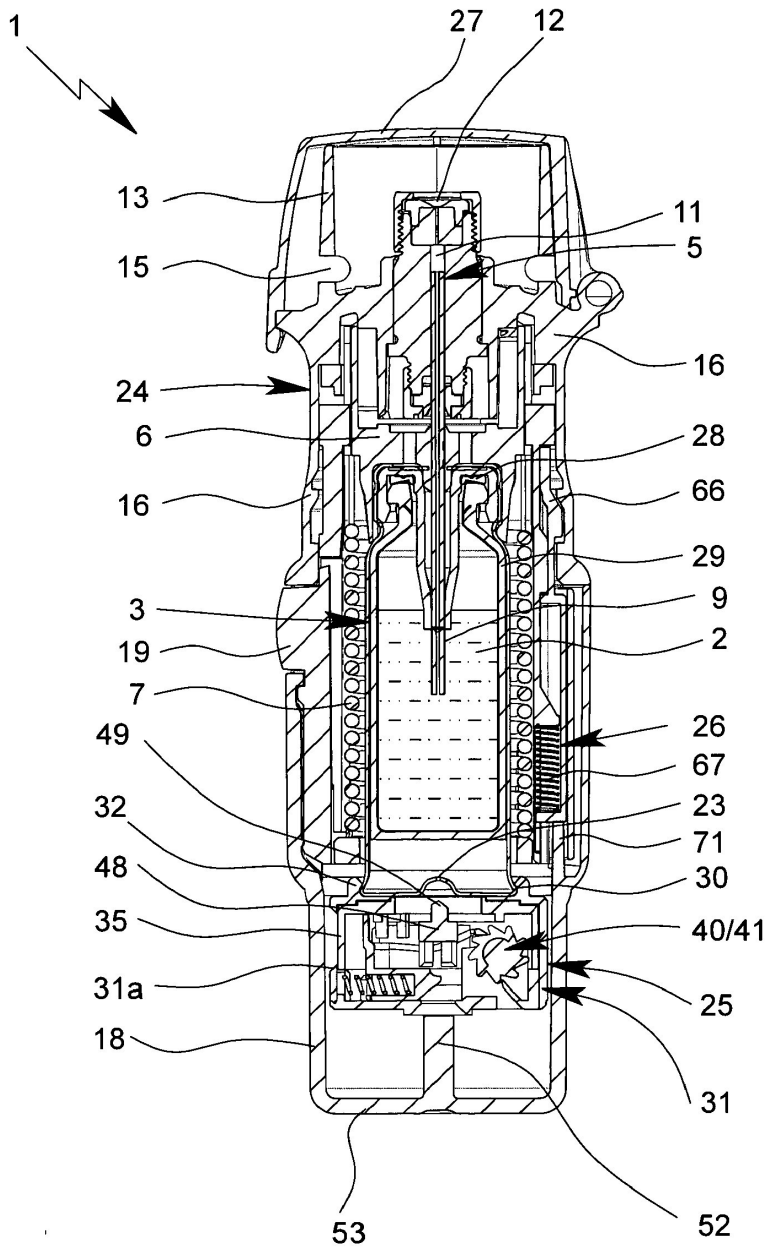

Fig. 18

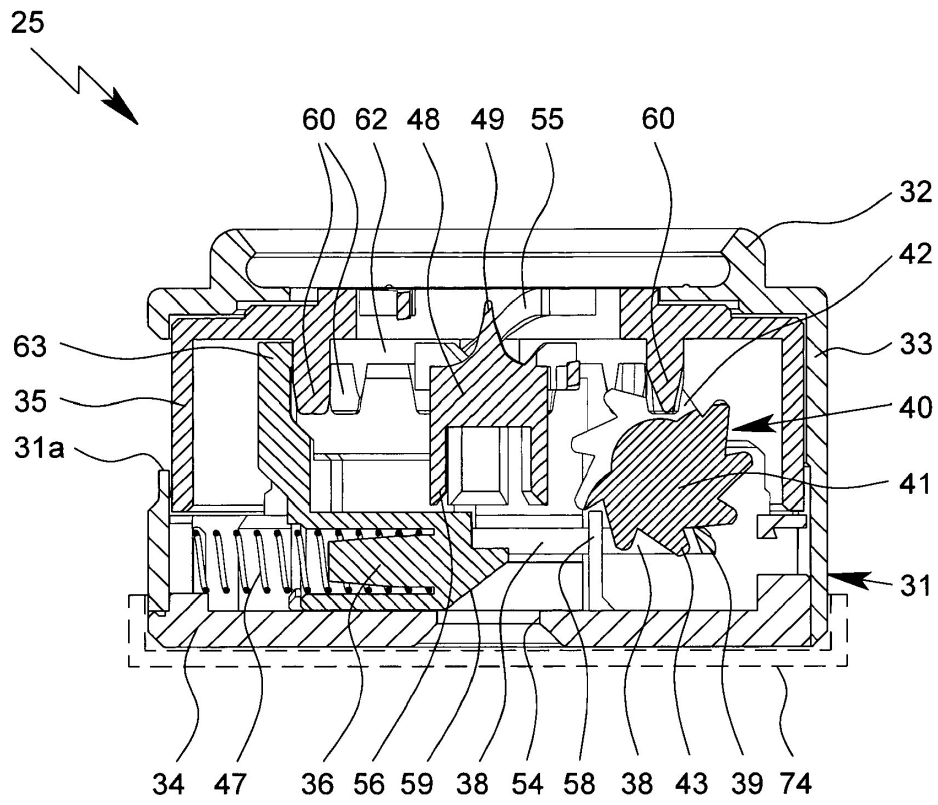

Fig. 19

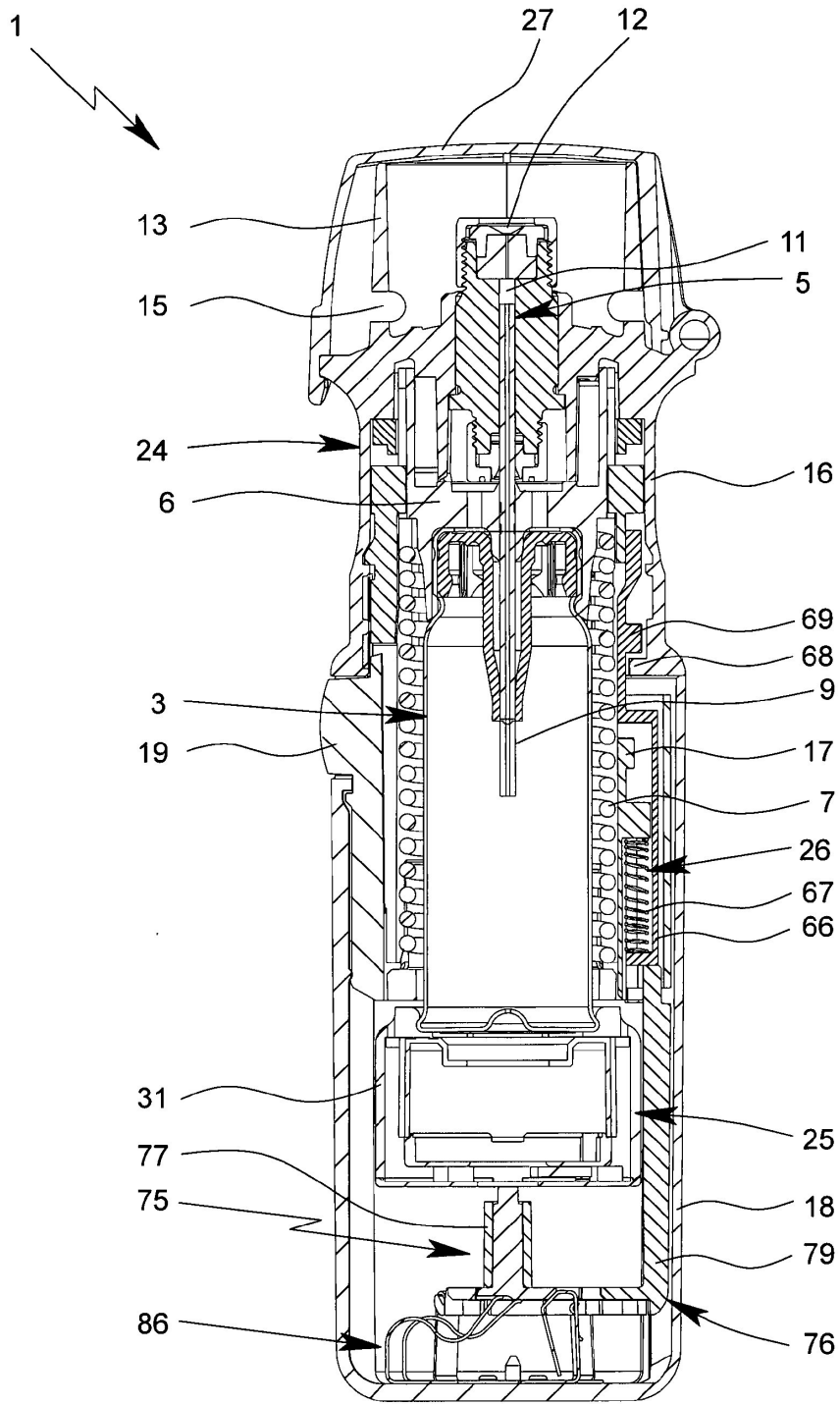

Fig. 21

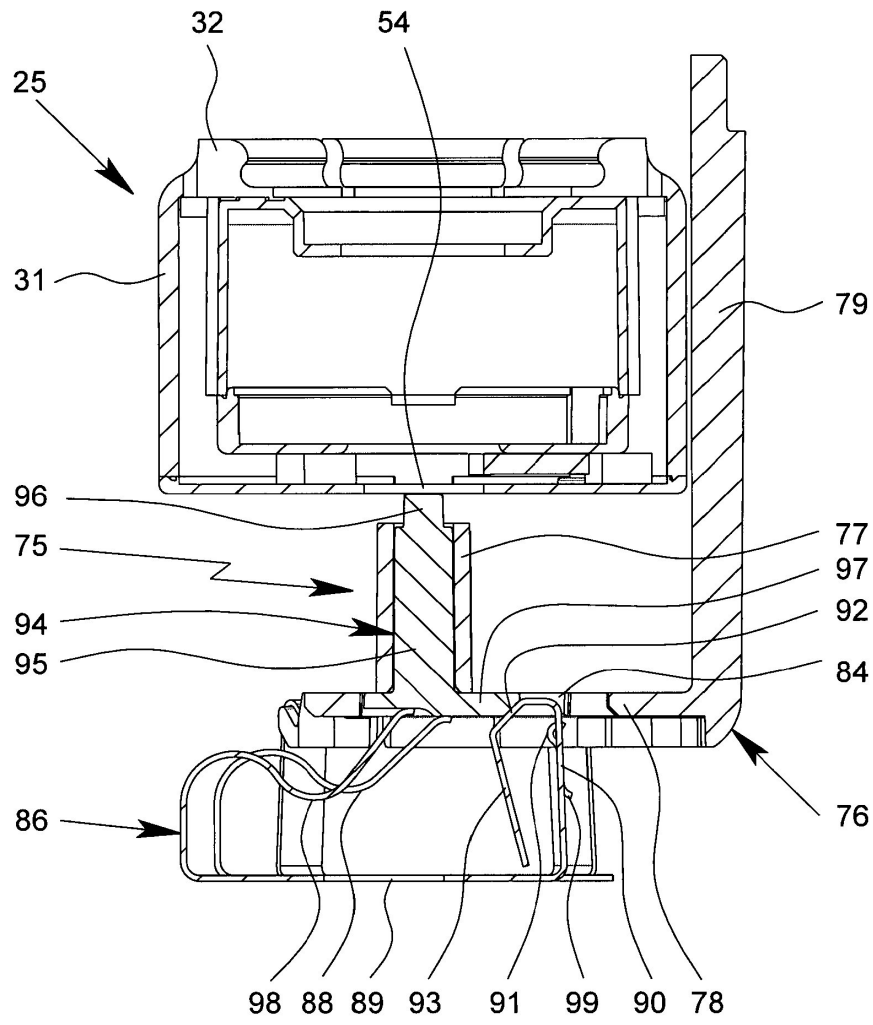

Fig. 22

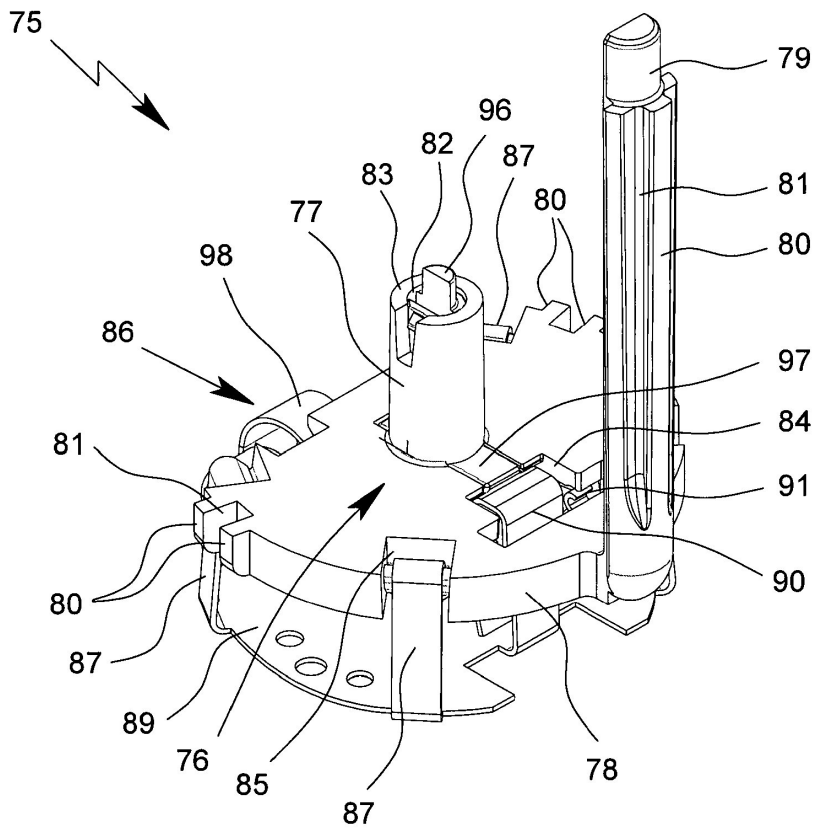

Fig. 23

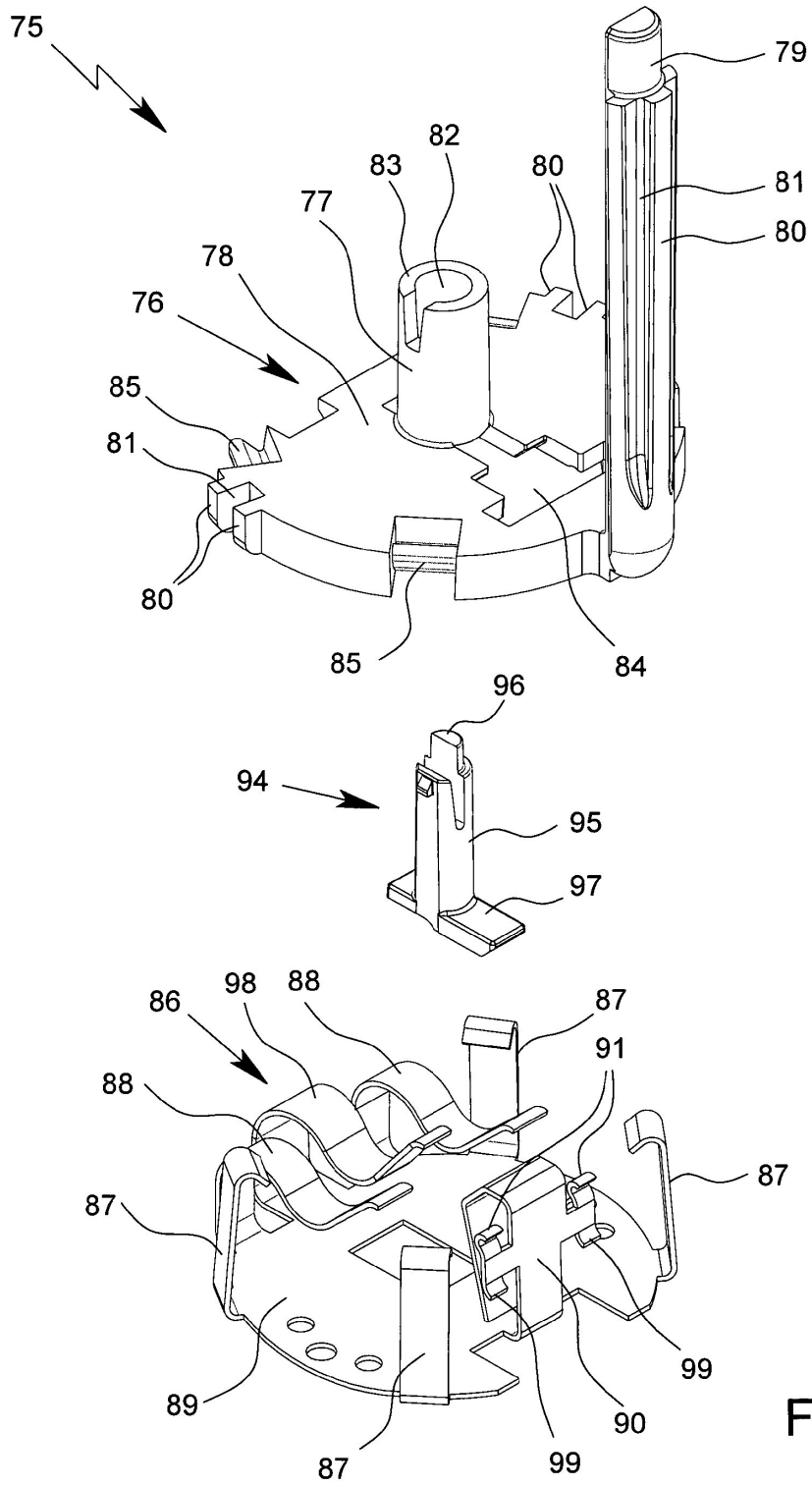

Fig. 24

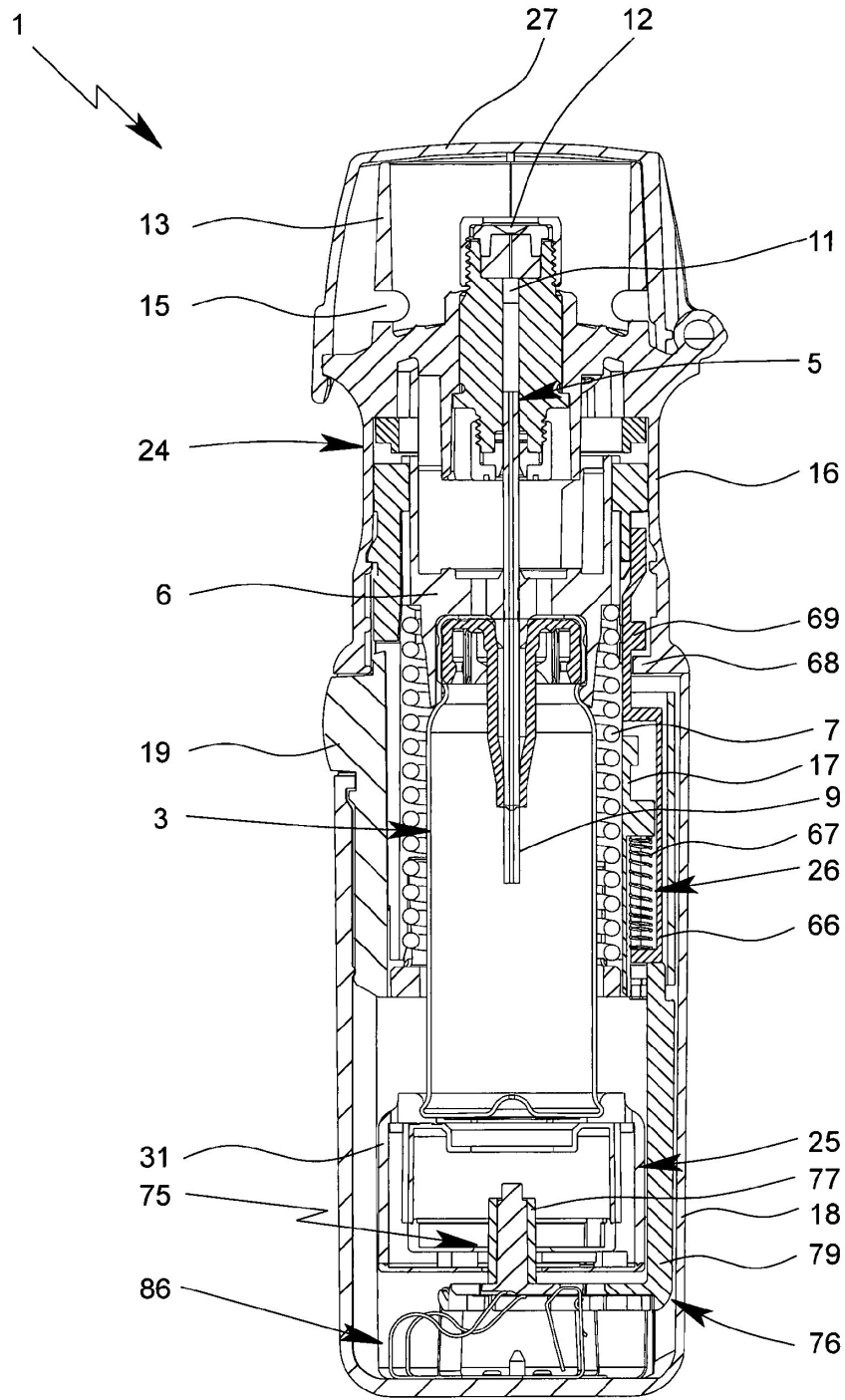

Fig. 25

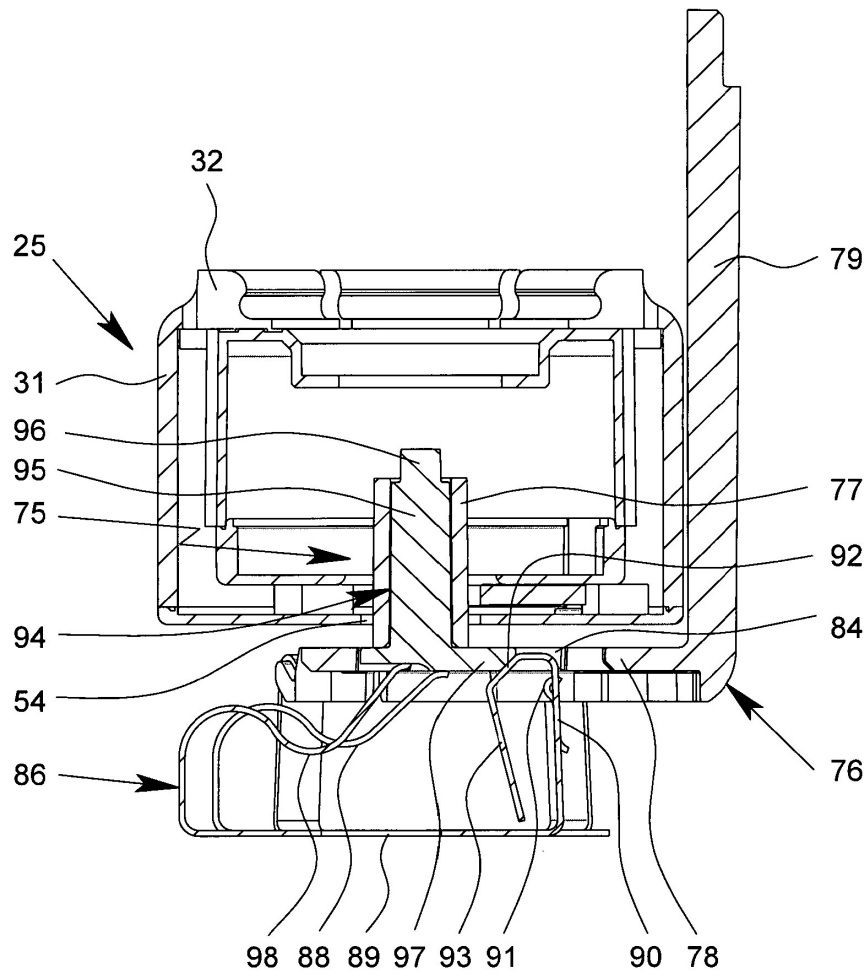

Fig. 26

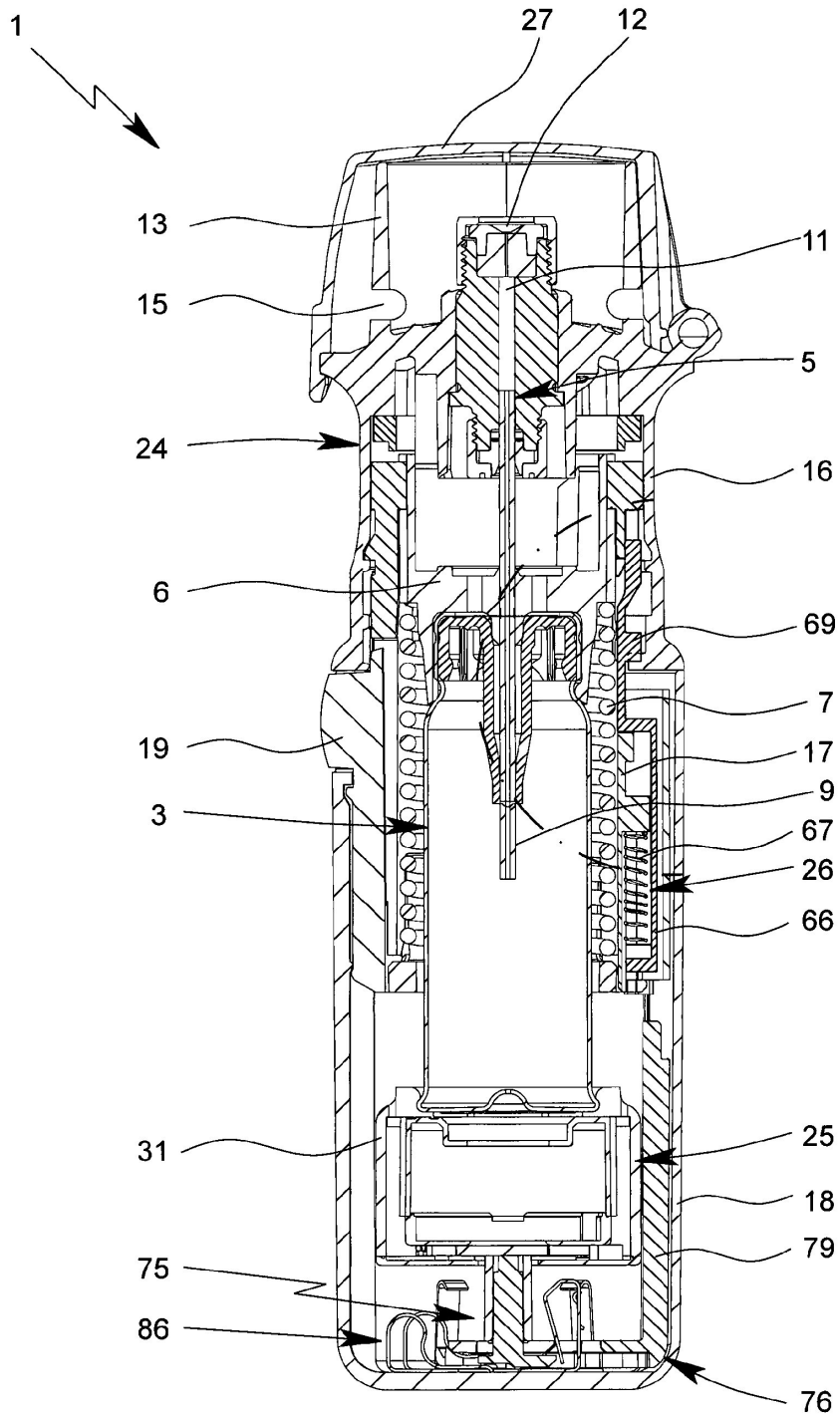

Fig. 27

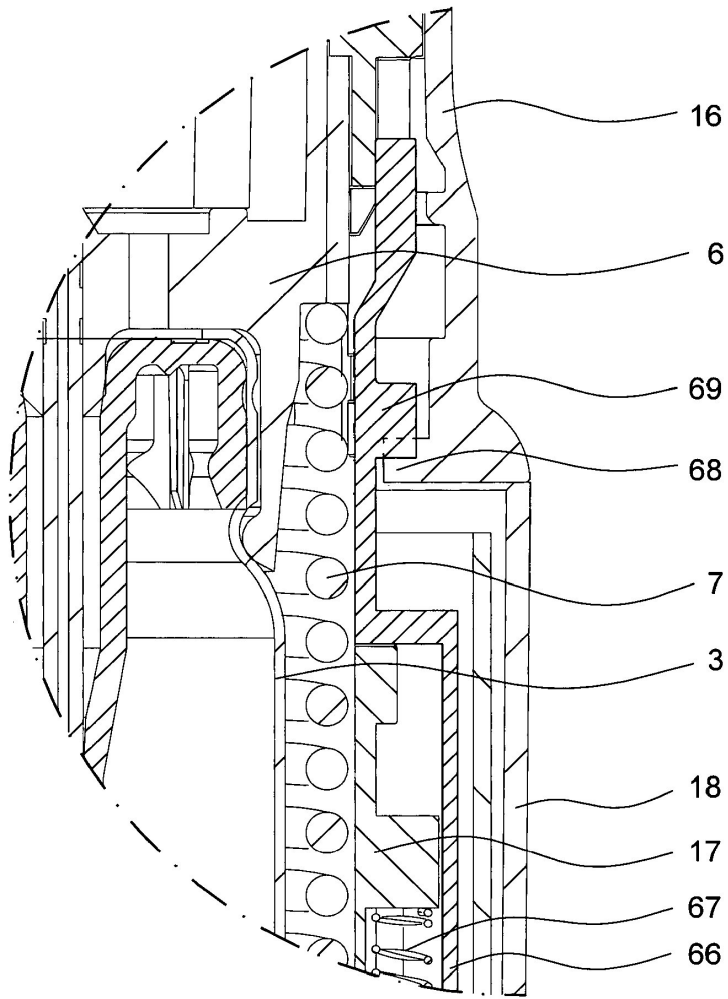

Fig. 28

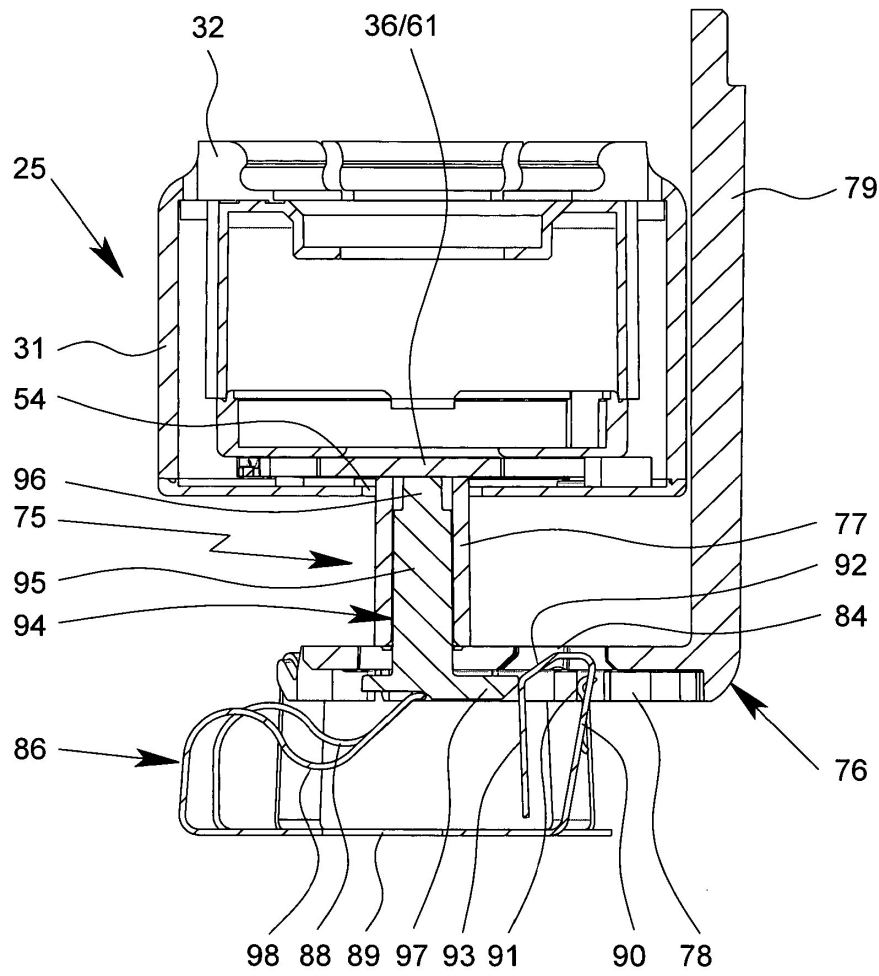

Fig. 29

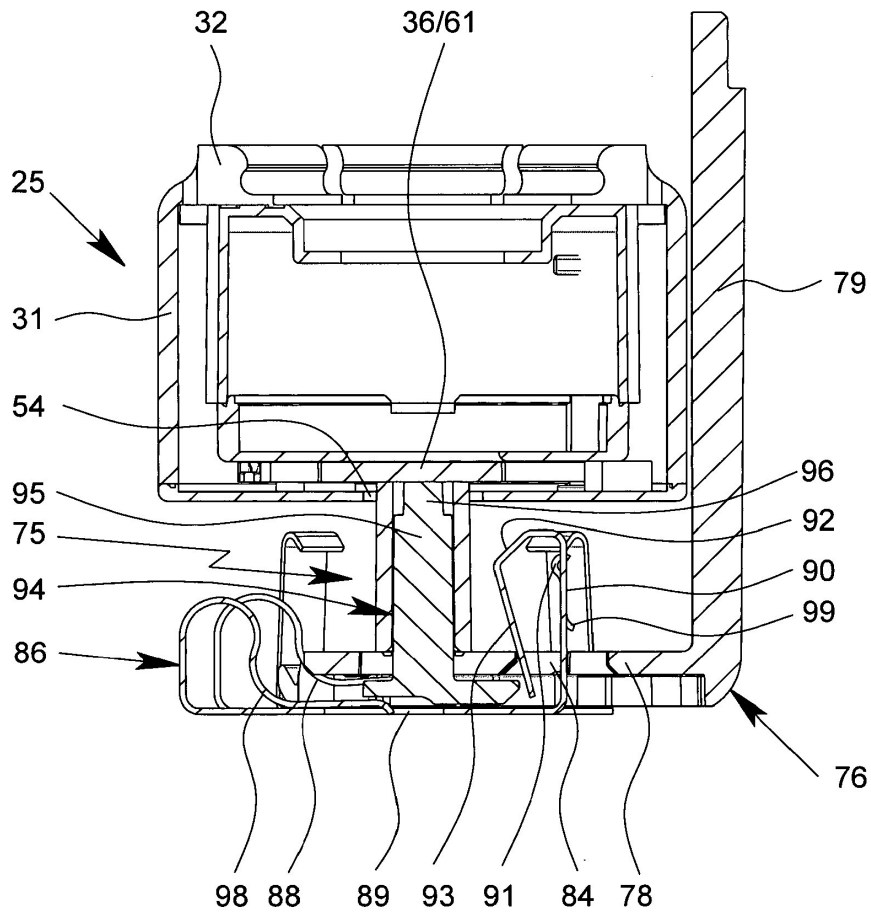

Fig. 30