

DESCRIPTION

Description

1. INTRODUCTION

[0001] The invention relates to dose escalation enzyme replacement therapy using acid sphingomyelinase (ASM) for the treatment of human subjects having acid sphingomyelinase deficiency (ASMD), and, in particular, the non-neurological manifestations of Niemann Pick Disease (NPD) , and in certain embodiments, NPD type B.

2. BACKGROUND

[0002] Acid sphingomyelinase, E.C. 3.1.4.12, (ASM) is a lysosomal phosphodiesterase enzyme that hydrolyzes sphingomyelin, a phospholipid storage substance found in the brain, liver, lungs, spleen and lymph nodes, to ceramide and phosphorylcholine. Deficiencies in ASM activity result in the inability of the body to break down sphingomyelin, causing a form of the lysosomal storage disease termed Niemann-Pick disease.

[0003] Niemann-Pick disease is an inherited autosomal recessive lipid storage disorder characterized by excessive accumulation of sphingomyelin in the lysosomes of cells such as macrophages and neurons, which impairs normal cellular function. Niemann-Pick Type A is a rapidly progressive neurodegenerative disease in infants and typically results in death within two to three years of age. Niemann-Pick Type B results in the enlargement of the liver and spleen, and respiratory distress with death generally ensuing by early adulthood. These two forms of Niemann-Pick disease which are both associated with ASM deficiencies are referred to collectively herein as Niemann-Pick disease, or ASM deficiency (ASMD). Other types of Niemann-Pick disease, e.g., Type C, do not involve mutations in the ASM gene and are not directly attributable to the function of ASM. The nature of the biochemical and molecular defects that underlie the remarkable clinical heterogeneity of the A and B subtypes remains unknown. Although patients with both subtypes have residual ASM activity (about 1 to 10% of normal), biochemical analysis cannot reliably distinguish the two phenotypes. Moreover, the clinical course of Type B NPD is highly variable, and it is not presently possible to correlate disease severity with the level of residual ASM activity.

[0004] NPD occurs more frequently among individuals of Ashkenazi Jewish ancestry than in the general population. It is estimated that the incidence of the type A disease among Ashkenazi Jews is about 1 in 40,000, a gene frequency (q) of about 1 in 200, and a heterozygote carrier frequency (2 pq) of 1 in 100 (Goodman, 1979, in "Genetic Disorders Among The Jewish

People", John Hopkins Univ. Press, Baltimore, pp. 96-100). The heterozygote carrier incidence of type B NPD in the Ashkenazi Jewish population is less frequent (Goodman, supra). The combined heterozygote carrier frequency for types A and B NPD has been estimated to be about 1 in 70 among individuals of Ashkenazi Jewish descent. Although the enzymatic diagnosis of affected patients with either type A or B NPD can be made reliably (Spence and Callahan, supra), the enzymatic detection of obligate heterozygotes has proven problematic, particularly using peripheral leukocytes as the enzyme source. Presumably, the occurrence of neutral sphingomyelinases in some sources and/or the presence of residual ASM activity resulting from the mutant allele have contributed to the inability to reliably discriminate carriers for either disease subtype. Even the use of cultured skin fibroblasts, which do not express the neutral sphingomyelinase, has not provided unambiguous results with heterozygotes. In epidemiologic studies conducted in individual countries, the combined incidence of Niemann-Pick A and B disease in several countries in the world is estimated to range from 1 in 167,000 to 1 in 250,000 newborns (Miekle et al., 1999 JAMA 281(3):249-254; Poorthuis et al., 1999 Hum Genet 105:151-156; Pinto et al., 2004 Euro. J. Hum. Gene. 12:87-92). The heterozygote carrier rate is believed to range from 1 in 200 to 1 in 250 individuals.

[0005] WO 2007/084737 A2 discloses acid sphingomyelinase (ASM) for use in the treatment of Niemann-Pick A or B disease, whereby ASM is to be administered via intraventricular delivery. Dodge et al. (Exp. Neurol. 2009; 215(2): 349-57) describes that intracerebroventricular infusion of ASM corrects CNS manifestations in a mouse model of Niemann-Pick A disease. Ziegler et al. (Mol. Genet. Metab. 2009; 97(1): 35-42) discloses that pulmonary delivery by intranasal instillation of recombinant human ASM (rhASM) into ASM deficient mice improved the clearance of lysosomal sphingomyelin from the lungs. Miranda et al. (FASEB J. 2000; 14(13): 1988-95) describes that infusion of rhASM into ASM deficient mice resulted into visceral but not neurological correction of the pathophysiology. Simonaro et al. (Am. J. Hum. Genet. 2002; 71(6): 1413-9) discloses mutations in the gene encoding ASM in patients with Niemann-Pick disease, including H421Y, Δ R608, R496L and L302P.

[0006] Enzyme replacement therapy has been used for other lysosomal storage diseases. Enzyme replacement therapy attempts to supplement the deficient enzyme activity with exogenously supplied enzyme. In the case of enzyme replacement therapy for Niemann-Pick disease, the goal would be to enable the affected individual to process sphingomyelin and avoid its buildup within the lysosomes. To be effective, such therapy initially would require a sufficiently large amount of the replacement enzyme to break down the accumulated sphingomyelin as well as continued administration of replacement enzyme to avoid further accumulation of sphingomyelin.

3. SUMMARY

[0007] The invention provides a recombinant human acid sphingomyelinase (rhASM) for use in a method of treating an acid sphingomyelinase deficiency (ASMD) in a human subject in need thereof, the method comprising the following steps in the following order:

1. a. administering to the human subject at least one initial dose of 0.025 mg/kg to 0.05 mg/kg of said rhASM; and
2. b. administering to the human subject an escalating dose regimen at the following doses: (i) 0.1 mg/kg of said rhASM, (ii) 0.3 mg/kg of said rhASM, and (iii) 0.6 mg/kg of said rhASM, wherein each dose is administered at least once before elevating the dose to the next level, and wherein each dose is administered two weeks after the administration of the previous dose.

[0008] In some embodiments, the dose of 0.1 mg/kg is administered once before elevating the dose to the next level. In some embodiments, the dose of 0.3 mg/kg is administered twice before elevating the dose to the next level. In some embodiments, the dose of 0.6 mg/kg is administered twice before elevating the dose to the next level.

[0009] In some embodiments, the method further comprises the following dose: (iv) 1 mg/kg of said rhASM. In some embodiments, the method further comprises the following dose: (v) 2 mg/kg of said rhASM. In some embodiments, the method further comprises the following dose: (vi) 3 mg/kg of said rhASM.

[0010] In some embodiments, the method further comprises administering a maintenance dose of said rhASM to the human subject. In some embodiments, the maintenance dose is administered every two weeks.

[0011] In some embodiments, the maintenance dose is the highest dose tolerated. In some embodiments, the maintenance dose is 1 mg/kg to 3 mg/kg of said rhASM. In some embodiments, the maintenance dose is 3 mg/kg of said rhASM.

[0012] In some embodiments, the dose for a subject with a body mass index (BMI) > 30 is calculated based on a calculated body weight corresponding to a BMI of 30 using the subject's height.

[0013] In some embodiments, the ASMD is Niemann Pick Disease (NPD) type A. In some embodiments, the ASMD is NPD type B.

[0014] In some embodiments, the human subject has a mutation in the gene encoding acid sphingomyelinase. In some embodiments, the mutation is a missense mutation. In some embodiments, the mutation is L302P, H421Y, or R496L. In some embodiments, the mutation is a deletion mutation. In some embodiments, the mutation is Δ R608.

[0015] In some embodiments, the doses are administered intravenously.

[0016] In some embodiments, the human subject is a human child.

[0017] The invention relates to dose escalation enzyme replacement therapy for the treatment

of human subjects having ASMD - particularly subjects having non-neurological manifestations of NPD, and in particular embodiments, NPD type B. More particularly, the enzyme, ASM, is administered to such patients at an initial low, non-toxic dose that is then escalated in subsequent administrations. The highest dose of ASM tolerated by the patient can then be used as a maintenance dose. Alternatively, a therapeutically effective dose less than the highest dose tolerated can be used as a maintenance dose.

[0018] The invention is based, in part, on the discovery that doses of ASM that would be required to clear accumulated sphingomyelin substrate in human subjects, *i.e.*, ASMD patients or Niemann-Pick patients, result in toxic side effects (including clinical signs of toxicity). This is especially surprising in the less severe form of ASMD, NPD type B patients who are deficient but have at least some enzyme activity.

[0019] More particularly, treatment of NPD would require doses high enough to achieve adequate distribution of the ASM enzyme in organs of pathology (*e.g.*, in particular, the liver, spleen, lungs, heart, kidney and brain). Studies in an ASM knockout mouse model (ASKMO mice) showed that the majority of recombinant human ASM (rhASM) administered distributes to the liver and spleen where it reduces substrate, but to a much lesser extent in lung, heart and brain (Miranda et al. FASEB 2000, 14:1988; *see also*, Figure 9B of He et al., 1999, *Biochimica et Biophysica Acta* 1432: 251-264). In subsequent studies using higher doses of rhASM in the ASMKO mouse model, substrate was reduced and toxicity was not observed at doses ≤ 3.0 mg/kg; in fact, clinical symptoms of toxicity was not observed until doses ≥ 10 mg/kg were used. See, "Dose Responsive Toxicological Findings Following Intravenous Administration of Recombinant Human Acid Sphingomyelinase (rhASM) to Acid Sphingomyelinase Knock-out (ASKMO) Mice. C. Nickerson, J. Murray, A. Vitsky, M. Hawes, S. Ryan, P. Ewing, B. Thurberg, L. Andrews. Dept Pharm/Tox, Pathology, Genzyme Corp., Framingham, MA., American Society of Human Genetics 2005; and Elevations of Pro-Inflammatory Cytokines and Decreases in Cardiovascular Hemodynamics Following Intravenous Administration of Recombinant Human Acid Sphingomyelinase (rhASM) to Acid Sphingomyelinase Knock-out (ASKMO) Mice. J. Murray, A.M. D'Angona, C. Nickerson, A. Vitsky, M. Hawes, S. Ryan, P. Ewing, B. Thurberg, L. Andrews. Dept. Pharmacology/Toxicology & Pathology, Genzyme Corp., Framingham, MA., Society of Toxicology 2006.

[0020] Based on these ASKMO data, we treated non-neuronopathic ASMD human subjects with a conservative maximum dose of 1.0 mg/kg rhASM as described in Section 6, *infra*. Quite unexpectedly, toxicity in the human subjects, including the onset of related adverse events with clinical symptoms, was observed using doses as low as 0.3 mg/kg! This result was especially surprising, since the ASM enzyme is absent in the knock out mouse model which should reflect a more severe condition than in these human subjects having at least some enzyme activity and relatively mild disease.

[0021] While not intended to be bound by any theory, the toxic side effects that occur with ASM treatment may result from breakdown of stored sphingomyelin substrate in the ASMD patient and release of the product, ceramide that is pro-apoptotic and induces a pro-inflammatory cytokine response and hyperbilirubinemia. To address this issue, we have developed a regimen

to allow for the safe administration of high doses of the ASM enzyme required to achieve adequate distribution in organs of pathology. In accordance with this regimen, initial treatment with ASM at very low doses is used to achieve a slow degradation of the stored substrate which is accompanied by fewer side effects. As the substrate is depleted in the subject (as the storage substrate is "debulked"), the dose can be escalated safely.

[0022] In accordance with this protocol, a low, non-toxic dose of the ASM enzyme is initially administered to a NPD disease patient and the dose is escalated over time. As the dose of the ASM enzyme is escalated, the patient can be monitored for total bilirubin concentration, the production of acute phase reactants, the production of inflammatory mediators, and related adverse events. The administration of a low dose of ASM and the escalation of the dose facilitates the debulking of the accumulated sphingomyelin. Once the patient is debulked, higher doses may be safely administered to the patient to ensure adequate distribution of the ASM enzyme to target organs (e.g., liver, spleen, lungs, heart, kidney, brain, bone marrow, skeleton, joints, etc.). In certain embodiments, the maximum dose tolerated by the patient can be used as the maintenance dose. In some embodiments, based upon a patient's condition, the maintenance dose may be increased or decreased over time.

[0023] In certain embodiments, treatment of the patient is monitored by measuring the plasma sphingomyelin levels, plasma ceramide levels, the production of "acute phase reactants" and inflammatory mediators that are a measure of inflammatory responses, bilirubin concentrations (total, direct, and indirect), and/or other biochemical markers to ensure a stable response before elevating the dose to the next level. These markers include, but are not limited to C-reactive protein (CRP) or high sensitivity CRP (hs-CRP), cytokines (e.g., IL-8, IL-6), calcitonin and ferritin. In specific embodiments, the patient may be monitored for one or more related adverse events, which may include, but are not limited to, constitutional symptoms (e.g., fever, nausea, vomiting, pain, myalgia) and jaundice.

[0024] Doses less than 1mg/kg are preferable for initiating treatment. The initial dose is successively elevated until a therapeutic dose is achieved. Such dose escalation can be used to determine the highest tolerated dose. For example, once the patient is debulked of the accumulated sphingomyelinase substrate, the dose may be further escalated until toxicity is observed. The maintenance dose can be adjusted accordingly, and can be continually and periodically readjusted depending on the status of the patient.

[0025] Generally, the present invention relates to an ASM for use in a method for treating a human subject having an acid sphingomyelinase deficiency, the method comprising: (a) a regimen for debulking accumulated sphingomyelin substrate in the human subject comprising: (i) administering an initial low non-toxic dose of ASM to the human subject; (ii) administering successively higher doses of ASM to the human subject, and monitoring the subject for one or more adverse side effects after each successive dose as indicated by elevated bilirubin or a related adverse event; and (b) a maintenance regimen comprising administering a dose equal to or less than the highest dose tolerated by the subject as the maintenance dose for the subject.

[0026] Further, the present invention relates to an ASM for use in a method for treating a human subject having an acid sphingomyelinase deficiency, the method comprising administering rhASM after the initial doses in an escalating dose regimen at the following sequential doses: 0.1 mg/kg; 0.3 mg/kg; 0.6 mg/kg; and 1.0 mg/kg, wherein each dose of rhASM is administered at least once, and each dose is administered at two week intervals. In some embodiments the patient is monitored for toxic side effects before elevating the dose to the next level.

[0027] In another specific embodiment the invention relates to an acid sphingomyelinase (ASM) for use in a method of treating of an acid sphingomyelinase deficiency in a human subject prepared to be administered: (a) in a regimen for debulking accumulated sphingomyelin substrate comprising: (i) administration of an initial low non-toxic dose of acid sphingomyelinase (ASM) as described above; (ii) administration of successively higher doses of ASM as described above, and monitoring the subject for one or more adverse side effects after each successive dose as indicated by elevated bilirubin or a related adverse event; and (b) in a maintenance regimen comprising administration of a dose equal to or less than the highest dose tolerated by the subject as the maintenance dose for the subject.

[0028] In another specific embodiment, the invention relates to a recombinant human ASM for use in a method of treating an acid sphingomyelinase deficiency in a human subject prepared to be administered in an escalating dose regimen at the following sequential doses: 0.1 mg/kg; 0.3 mg/kg; 0.6 mg/kg; and 1.0 mg/kg, wherein each dose of is administered at least twice, and each dose is administered at two week intervals, and wherein the subject is monitored for toxic side effects before elevating the dose to the next level.

3.1. TERMINOLOGY

[0029] As used herein, the terms "about" and "approximately" are used interchangeably in the context of a given value to refer to a range around a given value, wherein the resulting value is substantially the same as the expressly recited value. In a specific embodiment "about" means within 10%, 15%, 25% of a given value or range.

[0030] As used herein, the term "elderly human" refers to a human 65 years or older.

[0031] As used herein, the term "human adult" refers to a human that is 18 years or older.

[0032] As used herein, the term "human child" refers to a human that is 1 year to 18 years old.

[0033] As used herein, the term "human infant" refers to a newborn to 1 year old year human.

[0034] As used herein, the term "human toddler" refers to a human that is 1 year to 3 years old.

[0035] As used herein, the term "adverse event" refers to "any untoward medical occurrence in

a patient or clinical investigation subject administered a pharmaceutical product" as defined in the Clinical Data Interchange Standards Consortium Study Data Tabulation Model standard terminology v. 3.1.1. A "related adverse event" is an adverse event that has a causal relationship with treatment.

[0036] As used herein, the term "maintenance dose(s)" and the like refers to a dosage administered to ASMD patients to maintain the desired therapeutic effect. In specific embodiments, the maintenance dose(s) maintains one, two, three, four or more the following desired therapeutic effects: (i) a reduction in spleen volume as assessed by techniques known in the art, e.g., MRI; (ii) a reduction in liver sphingomyelin levels as assessed by techniques known in the art, e.g., biochemical analysis and/or histomorphometric analysis of liver samples; (iii) an increase in exercise capacity as assessed by techniques known in the art, e.g., maximum workload by cycle ergometry, including percent predicted maximum workload, peak oxygen consumption and carbon dioxide production; (iv) an increase in pulmonary function as assessed by techniques known in the art, e.g., techniques described in American Thoracic Society, 1991, Am. Rev. Respir. Dis. 144: 1202-1218, such as diffusing capacity (DLco), percent predicted forced vital capacity (FVC) as measured by, e.g., spirometric techniques, forced expiratory volume within 1 second (FEV₁) as measured by, e.g., spirometric techniques, and total lung capacity; (v) a decrease in bronchial alveolar lavage (BAL) sphingomyelin; (vi) a decrease in liver volume as assessed by techniques known in the art, e.g., MRI; (vii) an improvement in lung appearance as assessed by techniques known in the art, e.g., high resolution computed tomography (CT) scan or chest X-ray; (viii) a decrease in sphingomyelin concentration in the liver, skin, plasma and dried blood spot (DBS) as measured by, e.g., tandem mass spectrometry; (ix) a reduction or the amelioration of the severity of ASMD and/or a symptom associated therewith; (x) a reduction in the duration of a symptom associated with ASMD; (xi) the prevention in the recurrence of a symptom associated with ASMD; (xii) a reduction in hospitalization of a subject; (xiii) a reduction in hospitalization length; (xiv) an increase in the survival of a subject; (xv) a reduction in mortality; (xvi) a decrease in hospitalization rate; (xvii) a reduction in the number of symptoms associated with ASMD; (xviii) an increase in symptom-free survival of ASMD patients; (xix) an improvement in neurological function (e.g., psychomotor function, social responsiveness, etc.); (xx) an improvement in lung clearance as measured by, e.g., BAL cell count and profile; (xxi) a decrease in serum levels of chitotriosidase; (xxii) a decrease in serum levels of chemokine (c-c) motif ligand 18 (CCL18); (xxiii) an improvement in lipid profile (e.g., HDL, LDL, cholesterol, triglycerides, and total cholesterol:HDL ratio); and (xxiv) improved quality of life as assessed by, e.g., a questionnaire. In certain embodiments, the maintenance dose is the highest or maximum dose tolerated by a patient.

[0037] In some examples, the maintenance dose is a dose of between 0.5 mg/kg to 1.5 mg/kg, 0.75 mg/kg to 1.25 mg/kg, 1 mg/kg to 2.5 mg/kg, 1 mg/kg to 2.75 mg/kg, 1.5 mg/kg to 2.5 mg/kg, 1.5 mg/kg to 2.75 mg/kg, 2 mg/kg to 2.5 mg/kg, 2 mg/kg to 2.75 mg/kg, 2.5 mg/kg to 2.75 mg/kg, 2.5 mg/kg to 3 mg/kg, 3 mg/kg to 4 mg/kg, 3 mg/kg to 5 mg/kg, 4 mg/kg to 5 mg/kg, 2 mg/kg to 5 mg/kg or 5 mg/kg to 10 mg/kg of ASM. In certain embodiments, the maintenance dose is a dose of between 5 mg/kg to 15 mg/kg, 10 mg/kg to 15 mg/kg, 10 mg/kg to 20 mg/kg, 15 mg/kg to 20 mg/kg, 20 mg/kg to 30 mg/kg, 25 mg/kg to 50 mg/kg, 30 mg/kg to 40 mg/kg, 30

mg/kg to 45 mg/kg or 40 mg/kg to 50 mg/kg of ASM. In some embodiments, the maintenance dose is 0.75 mg/kg, 0.80 mg/kg, 0.85 mg/kg, 0.90 mg/kg, 0.95 mg/kg, 1 mg/kg, 1.1 mg/kg, 1.2 mg/kg, 1.25 mg/kg, 1.3 mg/kg, 1.4 mg/kg, 1.5 mg/kg, 1.75 mg/kg, or 2 mg/kg of ASM. In certain embodiments, the maintenance dose is 2.5 mg/kg, 2.75 mg/kg, 3 mg/kg, 3.25 mg/kg, 3.5 mg/kg, 3.75 mg/kg, 4 mg/kg, 4.25 mg/kg, 4.5 mg/kg, 4.75 mg/kg, 5 mg/kg, 5.5 mg/kg, 6 mg/kg, 6.5 mg/kg, 7 mg/kg, 7.5 mg/kg, 8 mg/kg, 8.5 mg/kg, 9 mg/kg, 9.5 mg/kg or 10 mg/kg of ASM. In some embodiments, the maintenance dose is 11 mg/kg, 12 mg/kg, 13 mg/kg, 14 mg/kg, 15 mg/kg, 20 mg/kg, 25 mg/kg, 30 mg/kg, 35 mg/kg, 40 mg/kg, 45 mg/kg or 50 mg/kg of ASM. In some embodiments, the maintenance dose is at least 1 mg/kg, at least 2 mg/kg, at least 3 mg/kg, at least 4 mg/kg, at least 5 mg/kg, at least 6 mg/kg, at least 7 mg/kg, at least 8 mg/kg of ASM with the highest dose being 10 mg/kg of ASM. In certain embodiments, the maintenance dose is at least 10 mg/kg, at least 15 mg/kg, at least 20 mg/kg, at least 25 mg/kg, at least 30 mg/kg, or at least 35 mg/kg of ASM with the highest dose being 50 mg/kg.

[0038] As used herein, the term "non-toxic dose(s)" and the like refers to a dosage administered to ASMD patients without resulting in one, two, three or all of the following: (i) a moderate or severe related adverse event as defined by a clinical symptom that interferes with normal daily functioning and requires additional monitoring, intervention, or treatment, or, an abnormal laboratory value or procedural result of clinical concern that requires further monitoring, treatment, or investigation. See, e.g., the Clinical Data Interchange Standards Consortium Study Data Tabulation Model standard terminology v.3.1.1; (ii) a total bilirubin value of greater than 1.5 mg/dL, 1.75 mg/dL, 2.0 mg/dL, 2.1 mg/dL, 2.2 mg/dL, 2.3 mg/dL, 2.4 mg/dL, 2.5 mg/dL, 2.6 mg/dL, 2.7 mg/dL, 2.75 mg/dL, 2.8 mg/dL, 2.9 mg/dL, 3.0 mg/dL, 3.1 mg/dL, 3.2 mg/dL, 3.3 mg/dL, 3.4 mg/dL, 3.5 mg/dL, 3.6 mg/dL, 3.7 mg/dL, 3.8 mg/dL, 3.9 mg/dL or 4 mg/dL or in the range of 2.1 mg/dL to 2.5 mg/dL, 2.1 mg/dL to 3.0 mg/dL, or 2.1 mg/dL to 4 mg/dL that lasts for greater than 18 hours, 24 hours, 36 hours, 48 hours or 72 hours, 5 days, one week, two weeks or three weeks after administration of the dose of ASM; (iii) a plasma ceramide concentration of greater than 8.2 µg/mL, 8.3 µg/mL, 8.4 µg/mL, 8.5 µg/mL, 8.75 µg/mL, 9 µg/mL, 9.5 µg/mL, 10 µg/mL, 11 µg/mL, 12 µg/mL, 13 µg/mL, 14 µg/mL, 15 µg/mL, 16 µg/mL, 17 µg/mL, 18 µg/mL, 19 µg/mL, 20 µg/mL, 25 µg/mL, 30 µg/mL, 35 µg/mL, 40 µg/mL, 45 µg/mL, 50 µg/mL, 55 µg/mL, 60 µg/mL, 65 µg/mL, 70 µg/mL, 75 µg/mL, or 80 µg/mL, or in the range of 8.2 µg/mL to 10 µg/mL, 8.5 µg/mL to 10 µg/mL, 9 µg/mL to 12 µg/mL, 10 µg/mL to 12 µg/mL, 10 µg/mL to 15 µg/mL, 10 µg/mL to 20 µg/mL, 15 µg/mL to 20 µg/mL, or 20 µg/mL to 30 µg/mL 6 hours, 8 hours, 10 hours, 12 hours, 16 hours, 18 hours, 24 hours, 36 hours, 48 hours or 72 hours after administration of the dose of ASM; or (iv) an acute phase response/reaction. The "non-toxic dose" of ASM may vary depending upon, e.g., the stability of the enzyme used, the activity of the enzyme used, and/or the route of administration of the enzyme. For example, the dose of a modified ASM enzyme with increased activity may be lower than the dosage of an unmodified ASM. One skilled in the art would be able to adjust the dose of enzyme administered based on the stability of the enzyme, the activity of the enzyme, and/or the route of administration of the enzyme.

[0039] An acute phase reaction is an early reaction (generally, e.g., within 12 to 72 hours) following administration of ASM that is indicative of an inflammatory response. An acute phase response can be assessed by a change in the concentration of an acute phase reactant (such as, e.g., CRP/hs-CRP, ferritin, fibrinogen, iron or transferrin), a change in the percentage of

neutrophils, a change in prothrombin time, or a change in partial thromboplastin time. In a specific embodiment, an increase in CRP/hs-CRP concentration 6 hours, 8 hours, 12 hours, 18 hours, 24 hours, 36 hours, 48 hours or 72 hours after administration of a dose of ASM relative to a patient's CRP/hs-CRP concentration prior to administration of ASM can be utilized as a measurement of an acute phase response. In another specific embodiment, a plasma CRP/hs-CRP concentration that is greater than the normal plasma CRP/hs-CRP concentration 6 hours, 8 hours, 12 hours, 16 hours, 18 hours, 24 hours, 36 hours, 48 hours or 72 hours after administration of the dose of ASM can be utilized as a measurement of an acute phase response. In certain embodiments, a plasma CRP/hs-CRP concentration of greater than approximately 8.1 mg/L, 8.2 mg/L, 8.3 mg/L, 8.4 mg/L, 8.5 mg/L, 9 mg/L, 9.5 mg/L, 10 mg/L, 11 mg/L, or 12 mg/L, or in the range of 8.5 mg/L to 10 mg/L, or 8.5 mg/dL to 12 mg/L, or 10 mg/L to 12 mg/L 6 hours, 8 hours, 12 hours, 16 hours, 18 hours, 24 hours, 36 hours, 48 hours or 72 hours after administration of the dose of ASM can be used as a measurement of an acute phase response.

[0040] In a specific embodiment, an increase in ferritin concentration 6 hours, 8 hours, 12 hours, 16 hours, 18 hours, 24 hours, 36 hours, 48 hours or 72 hours after administration of a dose of ASM relative to a patient's ferritin concentration prior to administration of ASM can be used as a measurement of an acute phase response. In another specific embodiment, a plasma ferritin concentration that is greater than the normal plasma ferritin concentration 6 hours, 8 hours, 12 hours, 18 hours, 24 hours, 36 hours, 48 hours or 72 hours after administration of the dose of ASM can be used as a measurement of an acute phase response. In certain embodiments, a plasma ferritin concentration of greater than approximately 300 ng/mL, 325 ng/mL, 350 ng/mL, 375 ng/mL, 400 ng/mL, 425 ng/mL, 450 ng/mL, 475 ng/mL, 500 ng/mL, 525 ng/mL, 550 ng/mL, 575 ng/mL, 600 ng/mL, 625 ng/mL, 650 ng/mL, 675 ng/mL, 700 ng/mL, 725 ng/mL, 750 ng/mL, 775 ng/mL, 800 ng/mL, 850 ng/mL, 900 ng/mL, 950 ng/mL, 1000 ng/mL, 1050 ng/mL, 1100 ng/mL, 1150 ng/mL, or 1200 ng/mL or in the range of 600 ng/mL to 800 ng/mL, 650 ng/mL to 850 ng/mL, 600 ng/mL to 1000 ng/mL, 600 ng/mL to 1200 ng/mL, 800 ng/mL to 1000 ng/mL, 900 ng/mL to 1000 ng/mL, or 1000 ng/mL to 1200 ng/mL 6 hours, 8 hours, 12 hours, 16 hours, 18 hours, 24 hours, 36 hours, 48 hours or 72 hours after administration of the dose of ASM can be used as a measurement of an acute phase response.

[0041] In a specific embodiment, an increase in plasma or serum IL-8 concentration 6 hours, 8 hours, 12 hours, 16 hours, 18 hours, 24 hours, 36 hours, 48 hours or 72 hours after administration of a dose of ASM relative to a patient's IL-8 concentration prior to administration of ASM can be used as a measurement of an acute phase response. In another specific embodiment, a plasma or serum IL-8 concentration that is greater than the normal plasma IL-8 concentration 6 hours, 8 hours, 12 hours, 18 hours, 24 hours, 36 hours, 48 hours or 72 hours after administration of the dose of ASM can be used as a measurement of an acute phase response. In certain embodiments, a plasma IL-8 concentration of greater than approximately 24 pg/mL, 50 pg/mL, 75 pg/mL, 100 pg/mL, 200 pg/mL, 300 pg/mL, 400 pg/mL, 500 pg/mL, 600 pg/mL, 700 pg/mL, 800 pg/mL, or 900 pg/mL, 6 hours, 8 hours, 12 hours, 16 hours, 18 hours, 24 hours, 36 hours, 48 hours or 72 hours after administration of the dose of ASM can be used as a measurement of an acute phase response.

[0042] In a specific embodiment, an increase in plasma or serum IL-6 concentration 6 hours, 8 hours, 12 hours, 16 hours, 18 hours, 24 hours, 36 hours, 48 hours or 72 hours after administration of a dose of ASM relative to a patient's IL-6 concentration prior to administration of ASM can be used as a measurement of an acute phase response. In another specific embodiment, a plasma or serum IL-6 concentration that is greater than the normal plasma or serum IL-6 concentration 6 hours, 8 hours, 12 hours, 18 hours, 24 hours, 36 hours, 48 hours or 72 hours after administration of the dose of ASM can be used as a measurement of an acute phase response. In certain embodiments, a plasma IL-6 concentration of greater than approximately 4.4 pg/mL, 6 pg/mL, 8 pg/mL, 10 pg/mL, 15 pg/mL, 20 pg/mL, 25 pg/mL, or 30 pg/mL, 6 hours, 8 hours, 12 hours, 16 hours, 18 hours, 24 hours, 36 hours, 48 hours or 72 hours after administration of the dose of ASM can be used as a measurement of an acute phase response.

[0043] In a specific embodiment, an increase in plasma or serum calcitonin concentration 6 hours, 8 hours, 12 hours, 16 hours, 18 hours, 24 hours, 36 hours, 48 hours or 72 hours after administration of a dose of ASM relative to a patient's calcitonin concentration prior to administration of ASM can be used as a measurement of an acute phase response. In another specific embodiment, a plasma or serum calcitonin concentration that is greater than the normal plasma calcitonin concentration 6 hours, 8 hours, 12 hours, 18 hours, 24 hours, 36 hours, 48 hours or 72 hours after administration of the dose of ASM can be used as a measurement of an acute phase response. In certain embodiments, a plasma calcitonin concentration of greater than approximately 9.4 pg/mL, 20 pg/mL, 30 pg/mL, 40 pg/mL, 50 pg/mL, 75 pg/mL, 100 pg/mL, 150 pg/mL, 200 pg/mL, or 250 pg/mL, 6 hours, 8 hours, 12 hours, 16 hours, 18 hours, 24 hours, 36 hours, 48 hours or 72 hours after administration of the dose of ASM can be used as a measurement of an acute phase response.

[0044] In a specific embodiment, an increase in fibrinogen concentration 6 hours, 8 hours, 12 hours, 16 hours, 18 hours, 24 hours, 36 hours, 48 hours or 72 hours after administration of a dose of ASM relative to a patient's fibrinogen concentration prior to administration of ASM can be used as a measurement of an acute phase response. In another specific embodiment, a plasma fibrinogen concentration that is greater than the normal plasma fibrinogen concentration 6 hours, 8 hours, 12 hours, 16 hours, 18 hours, 24 hours, 36 hours, 48 hours or 72 hours after administration of the dose of ASM can be used as a measurement of an acute phase response. In certain embodiments, a plasma fibrinogen concentration of greater than approximately 350 mg/dL, 375 mg/dL, 400 mg/dL, 425 mg/dL, or 450 mg/dL, or in the range of 350 mg/dL to 400 mg/dL, 350 mg/dL to 450 mg/dL or 400 mg/dL to 450 mg/dL 6 hours, 8 hours, 12 hours, 16 hours, 18 hours, 24 hours, 36 hours, 48 hours or 72 hours after administration of the dose of ASM can be used as a measurement of an acute phase response.

[0045] In one embodiment, an increase in the percentage of neutrophils of total white blood cells 6 hours, 8 hours, 12 hours, 16 hours, 18 hours, 24 hours, 36 hours, 48 hours or 72 hours after administration of a dose of ASM relative to a patient's percentage of neutrophils of total white blood cells prior to administration of ASM can be utilized as a measurement of an acute phase response. In another embodiment, an increase in the percentage of neutrophils of total

white blood cells that is greater than the normal percentage of neutrophils of total white blood cells concentration 6 hours, 8 hours, 12 hours, 16 hours, 18 hours, 24 hours, 36 hours, 48 hours or 72 hours after administration of the dose of ASM can be utilized as a measurement of an acute phase response. In certain embodiments, an increase in the percentage of neutrophils of total white blood cells that is 70%, 75%, 80%, 85%, 90%, 95% or greater 6 hours, 8 hours, 12 hours, 16 hours, 18 hours, 24 hours, 36 hours, 48 hours or 72 hours after administration of the dose of ASM can be utilized as a measurement of an acute phase response.

[0046] As used herein, the term "low, non-toxic dose(s)" and the like in the context of the initial dose or doses administered to a subject refers to a dosage that is the first dose or doses of ASM administered to a subject to treat ASMD that is non-toxic. In certain examples, a low, non-toxic dose(s) is a dose of 0.001 mg/kg to 0.01 mg/kg, 0.001 mg/kg to 0.01 mg/kg, 0.001 mg/kg to 0.05 mg/kg, 0.001 mg/kg to 0.1 mg/kg, 0.001 mg/kg to 0.5 mg/kg, 0.05 mg/kg to 0.275 mg/kg, 0.075 mg/kg to 0.275 mg/kg, 0.05 mg/kg to 0.2 mg/kg, 0.075 mg/kg to 0.2 mg/kg, 0.1 mg/kg to 0.275 mg/kg, 0.1 mg/kg to 0.25 mg/kg, 0.1 mg/kg to 1 mg/kg, 0.5 mg/kg to 1 mg/kg, 0.75 mg/kg to 1 mg/kg, 0.1 mg/kg to 2 mg/kg, 0.5 mg/kg to 2 mg/kg, 0.75 mg/kg to 2 mg/kg, 1 mg/kg to 2 mg/kg or 1.25 mg/kg to 2 mg/kg, 1.5 mg/kg to 2 mg/kg or 1.75 mg/kg to 2 mg/kg of ASM. In the context of the invention, a low, non-toxic dose is a dose of 0.025 mg/kg, or 0.05 mg/kg of ASM. Other exemplary doses are doses of 0.001 mg/kg, 0.005 mg/kg, 0.0075 mg/kg, 0.01 mg/kg, 0.0125 mg/kg, 0.075 mg/kg, 0.1 mg/kg, 0.125 mg/kg, 0.15 mg/kg, 0.175 mg/kg, 0.2 mg/kg, 0.225 mg/kg, 0.25 mg/kg, 0.275 mg/kg, 0.3 mg/kg, 0.4 mg/kg, 0.5 mg/kg, 0.6 mg/kg, 0.7 mg/kg, 0.75 mg/kg, 0.8 mg/kg, 0.9 mg/kg or 1 mg/kg of ASM.

[0047] The terms "subject" and "patient" are used herein interchangeably to refer to a human. In a specific embodiment, the human has or has been diagnosed as having an ASMD.

[0048] As used herein, the term "therapeutically effective" in the context of administering a dose of ASM to a subject refers to the amount of ASM that results in a beneficial or therapeutic effect. In specific embodiments, the term "therapeutically effective" in context of administering a dose of ASM to a subject refers to the amount of ASM refers which is sufficient to achieve at least one, two, three, four or more of the following effects: (i) a reduction in spleen volume as assessed by techniques known in the art, e.g., MRI; (ii) a reduction in liver sphingomyelin levels as assessed by techniques known in the art, e.g., biochemical analysis and/or histomorphometric analysis of liver samples; (iii) an increase in exercise capacity as assessed by techniques known in the art, e.g., maximum workload by cycle ergometry, including percent predicted maximum workload, peak oxygen consumption and carbon dioxide production; (iv) an increase in pulmonary function as assessed by techniques known in the art, e.g., techniques described in American Thoracic Society, 1991, Am. Rev. Respir. Dis. 144: 1202-1218, such as diffusing capacity (DLco), percent predicted forced vital capacity (FVC) as measured by, e.g., spirometric techniques, forced expiratory volume within 1 second (FEV₁) as measured by, e.g., spirometric techniques, and total lung capacity; (v) a decrease in bronchial alveolar lavage (BAL) sphingomyelin; (vi) a decrease in liver volume as assessed by techniques known in the art, e.g., MRI; (vii) an improvement in lung appearance as assessed by techniques known in the art, e.g., high resolution CT scan or chest X-ray; (viii) a decrease in sphingomyelin concentration

in the skin, plasma and dried blood spot (DBS) as measured by, e.g., tandem mass spectrometry; (ix) a reduction or the amelioration of the severity of ASMD and/or a symptom associated therewith; (x) a reduction in the duration of a symptom associated with ASMD; (xi) the prevention in the recurrence of a symptom associated with ASMD; (xii) a reduction in hospitalization of a subject; (vi) a reduction in hospitalization length; (xiii) an increase in the survival of a subject; (xiv) a reduction in mortality; (xv) a decrease in hospitalization rate; (xvi) a reduction in the number of symptoms associated with ASMD; (xvii) an increase in symptom-free survival of ASMD patients; (xviii) an improvement in neurological function (e.g., psychomotor function, social responsiveness, etc.); (xix) an improvement in lung clearance as measured by, e.g., BAL cell count and profile; (xx) a decrease in serum levels of chitotriosidase; (xxi) a decrease in serum levels of CCL18; (xxii) an improvement in lipid profile (e.g., HDL, LDL, cholesterol, triglycerides, and total cholesterol:HDL ratio); and (xxiii) improved quality of life as assessed by, e.g., a questionnaire.

[0049] As used herein, the terms "therapies" and "therapy" can refer to any protocol(s), method(s), compositions, formulations, and/or agent(s) that can be used in the treatment, management, or amelioration of ASMD or condition or symptom associated therewith. In certain embodiments, the terms "therapies" and "therapy" refer to biological therapy, supportive therapy, and/or other therapies useful in treatment, management, prevention, or amelioration of ASMD or condition or symptom associated therewith. In embodiments, the term "therapy" refers to a therapy that does one, two or more of the following: (i) enhances the delivery of ASM to sites of pathology, (ii) enhances the activity of ASM, and (iii) enhances the stability of ASM. In certain embodiments, the term "therapy" refers to a therapy other than ASM. In specific embodiments, an "additional therapy" and "additional therapies" refer to a therapy other than ASM.

[0050] As used herein, the term "toxic effect(s)" and the like refers one, two, three or all of the following subsequent to the administration of a dose(s) of ASM: (i) a moderate or severe related adverse event as defined by a clinical symptom that interferes with normal daily functioning and requires additional monitoring, intervention, or treatment, or, an abnormal laboratory value or procedural result of clinical concern that requires further monitoring, treatment, or investigation. See, e.g., the Clinical Data Interchange Standards Consortium Study Data Tabulation Model standard terminology v.3.1.1; (ii) a total bilirubin value of greater than 1.5 mg/dL, 1.75 mg/dL, 2.0 mg/dL, 2.1 mg/dL, 2.2 mg/dL, 2.3 mg/dL, 2.4 mg/dL, 2.5 mg/dL, 2.6 mg/dL, 2.7 mg/dL, 2.75 mg/dL, 2.8 mg/dL, 2.9 mg/dL, 3.0 mg/dL, 3.1 mg/dL, 3.2 mg/dL, 3.3 mg/dL, 3.4 mg/dL, 3.5 mg/dL, 3.6 mg/dL, 3.7 mg/dL, 3.8 mg/dL, 3.9 mg/dL or 4 mg/dL or in the range of 2.1 mg/dL to 2.5 mg/dL, 2.1 mg/dL to 3.0 mg/dL, or 2.1 mg/dL to 4 mg/dL that lasts for greater than 16 hours, 18 hours, 24 hours, 36 hours, 48 hours or 72 hours, 5 days, one week, two weeks or three weeks after administration of the dose of ASM; (iii) a plasma ceramide concentration of greater 8.2 µg/mL, 8.3 µg/mL, 8.4 µg/mL, 8.5 µg/mL, 8.75 µg/mL, 9 µg/mL, 9.5 µg/mL, 10 µg/mL, 11 µg/mL, 12 µg/mL, 13 µg/mL, 14 µg/mL, 15 µg/mL, 16 µg/mL, 17 µg/mL, 18 µg/mL, 19 µg/mL, 20 µg/mL, 25 µg/mL, 30 µg/mL, 35 µg/mL, 40 µg/mL, 45 µg/mL, 50 µg/mL, 55 µg/mL, 60 µg/mL, 65 µg/mL, 70 µg/mL, 75 µg/mL, or 80 µg/mL, or in the range of 8.2 µg/mL to 10 µg/mL, 8.5 µg/mL to 10 µg/mL, 9 µg/mL to 12 µg/mL, 10 µg/mL to 12 µg/mL, 10 µg/mL to 15 µg/mL, 10 µg/mL to 20 µg/mL, 15 µg/mL to 20 µg/mL, or 20 µg/mL to 30 µg/mL 6 hours, 8 hours, 10 hours, 12

hours, 16 hours, 18 hours, 24 hours, 36 hours, 48 hours or 72 hours after administration of the dose of ASM; or (iv) an acute phase response.

[0051] An acute phase response can be assessed by a change in the concentration of an acute phase reactant (such as, *e.g.*, C-reactive protein, ferritin, albumin, IL-8, IL-6, calcitonin, fibrinogen, iron or transferrin), a change in the percentage of neutrophils, a change in prothrombin time, or a change in partial thromboplastin time. In a specific embodiment, an increase in CRP/hs-CRP concentration 6 hours, 8 hours, 12 hours, 18 hours, 24 hours, 36 hours, 48 hours or 72 hours after administration of a dose of ASM relative to a patient's CRP/hs-CRP concentration prior to administration of ASM can be utilized as a measurement of an acute phase response. In another specific embodiment, a plasma CRP/hs-CRP concentration that is greater than the normal plasma CRP/hs-CRP concentration 6 hours, 8 hours, 12 hours, 16 hours, 18 hours, 24 hours, 36 hours, 48 hours or 72 hours after administration of the dose of ASM can be utilized as a measurement of an acute phase response. In certain embodiments, a plasma CRP/hs-CRP concentration of greater than approximately 8.1 mg/L, 8.2 mg/L, 8.3 mg/L, 8.4 mg/L, 8.5 mg/L, 8.6 mg/L, 8.7 mg/L, 8.8 mg/L, 8.8 mg/L, 8.9 mg/L, 9 mg/L, 9.5 mg/L, 10 mg/L, 11 mg/L, or 12 mg/L, or in the range of 8.5 mg/L to 10 mg/L, or 8.5 mg/L to 12 mg/L, or 10 mg/L to 12 mg/L 6 hours, 8 hours, 12 hours, 16 hours, 18 hours, 24 hours, 36 hours, 48 hours or 72 hours after administration of the dose of ASM can be used as a measurement of an acute phase response.

[0052] In a specific embodiment, an increase in ferritin concentration 6 hours, 8 hours, 12 hours, 16 hours, 18 hours, 24 hours, 36 hours, 48 hours or 72 hours after administration of a dose of ASM relative to a patient's ferritin concentration prior to administration of ASM can be used as a measurement of an acute phase response. In another specific embodiment, a plasma ferritin concentration that is greater than the normal plasma ferritin concentration 6 hours, 8 hours, 12 hours, 18 hours, 24 hours, 36 hours, 48 hours or 72 hours after administration of the dose of ASM can be used as a measurement of an acute phase response. In certain embodiments, a plasma ferritin concentration of greater than approximately 600 ng/mL, 625 ng/mL, 650 ng/mL, 675 ng/mL, 700 ng/mL, 725 ng/mL, 750 ng/mL, 775 ng/mL, 800 ng/mL, 850 ng/mL, 900 ng/mL, 950 ng/mL, 1000 ng/mL, 1050 ng/mL, 1100 ng/mL, 1150 ng/mL, or 1200 ng/mL or in the range of 600 ng/mL to 800 ng/mL, 650 ng/mL to 850 ng/mL, 600 ng/mL to 1000 ng/mL, 600 ng/mL to 1200 ng/mL, 800 ng/mL to 1000 ng/mL, 900 ng/mL to 1000 ng/mL, or 1000 ng/mL to 1200 ng/mL 6 hours, 8 hours, 12 hours, 16 hours, 18 hours, 24 hours, 36 hours, 48 hours or 72 hours after administration of the dose of ASM can be used as a measurement of an acute phase response.

[0053] In a specific embodiment, an increase in fibrinogen concentration 6 hours, 8 hours, 12 hours, 16 hours, 18 hours, 24 hours, 36 hours, 48 hours or 72 hours after administration of a dose of ASM relative to a patient's fibrinogen concentration prior to administration of ASM can be used as a measurement of an acute phase response. In another specific embodiment, a plasma fibrinogen concentration that is greater than the normal plasma fibrinogen concentration 6 hours, 8 hours, 12 hours, 16 hours, 18 hours, 24 hours, 36 hours, 48 hours or 72 hours after administration of the dose of ASM can be used as a measurement of an acute phase response.

In certain embodiments, a plasma fibrinogen concentration of greater than approximately 350 mg/dL, 375 mg/dL, 400 mg/dL, 425 mg/dL, or 450 mg/dL, or in the range of 350 mg/dL to 400 mg/dL, 350 mg/dL to 450 mg/dL or 400 mg/dL to 450 mg/dL 6 hours, 8 hours, 12 hours, 16 hours, 18 hours, 24 hours, 36 hours, 48 hours or 72 hours after administration of the dose of ASM can be used as a measurement of an acute phase response.

[0054] In a specific embodiment, a decrease in albumin concentration 6 hours, 8 hours, 12 hours, 18 hours, 24 hours, 36 hours, 48 hours or 72 hours after administration of a dose of ASM relative to a patient's albumin concentration prior to administration of ASM can be utilized as a measurement of an acute phase response. In certain embodiments, a decrease in the following magnitude of albumin concentration of 0.2, 0.4, 0.6, 1, 1.5, 2.0 g/dL from a normal range of 3.5 to 5.0 g/dL 6 hours, 8 hours, 12 hours, 16 hours, 18 hours, 24 hours, 36 hours, 48 hours or 72 hours after administration of the dose of ASM can be used as a measurement of an acute phase response.

[0055] In a specific embodiment, a decrease in ferritin concentration 6 hours, 8 hours, 12 hours, 18 hours, 24 hours, 36 hours, 48 hours or 72 hours after administration of a dose of ASM relative to a patient's ferritin concentration prior to administration of ASM can be utilized as a measurement of an acute phase response. In certain embodiments, a decrease in the following magnitude of ferritin concentration of 20, 40, 60, 80, 100, 120, 140, 160 mcg/dL from a normal range of 60 to 170 mcg/dL 6 hours, 8 hours, 12 hours, 16 hours, 18 hours, 24 hours, 36 hours, 48 hours or 72 hours after administration of the dose of ASM can be used as a measurement of an acute phase response.

[0056] In a specific embodiment, a decrease in transferrin concentration 6 hours, 8 hours, 12 hours, 18 hours, 24 hours, 36 hours, 48 hours or 72 hours after administration of a dose of ASM relative to a patient's transferrin concentration prior to administration of ASM can be utilized as a measurement of an acute phase response. In certain embodiments, a decrease in the following magnitude of transferrin concentration of 20, 40, 60, 80, 100, 120, 140, 160, 180 mg/dL from a normal range of 202 to 336 mg/dL 6 hours, 8 hours, 12 hours, 16 hours, 18 hours, 24 hours, 36 hours, 48 hours or 72 hours after administration of the dose of ASM can be used as a measurement of an acute phase response.

[0057] In one embodiment, an increase in the percentage of neutrophils of total white blood cells 6 hours, 8 hours, 12 hours, 16 hours, 18 hours, 24 hours, 36 hours, 48 hours or 72 hours after administration of a dose of ASM relative to a patient's percentage of neutrophils of total white blood cells prior to administration of ASM can be utilized as a measurement of an acute phase response. In another embodiment, an increase in the percentage of neutrophils of total white blood cells that is greater than the normal percentage of neutrophils of total white blood cells concentration 6 hours, 8 hours, 12 hours, 16 hours, 18 hours, 24 hours, 36 hours, 48 hours or 72 hours after administration of the dose of ASM can be utilized as a measurement of an acute phase response. In certain embodiments, an increase in the percentage of neutrophils of total white blood cells that is 70%, 75%, 80%, 85%, 90%, 95% or greater 6 hours, 8 hours, 12 hours, 16 hours, 18 hours, 24 hours, 36 hours, 48 hours or 72 hours after administration of the dose of ASM can be utilized as a measurement of an acute phase response.

4. BRIEF DESCRIPTION OF THE DRAWINGS

[0058]

Figure 1 is a graphic representation of the protocol design.

Figure 2 is a chart showing the demography and baseline characteristics of the patients enrolled in the protocol described below.

Figures 3A, 3B, and 3C are graphs depicting the plasma levels of ceramide (Figure 3A) and the plasma levels of sphingomyelin (Figure 3B), and the sphingomyelin level in dried blood spot (Figure 3C) over time in different patients being administered different doses of rhASM. The right axis of the graphs depict the patient number and the dosage of rhASM.

Figure 4 is a graph depicting the total bilirubin levels determined over time in different patients being administered different doses of rhASM during the protocol. The right axis of the graph depicts the patient number and the dosage of rhASM.

Figures 5A-5G are graphs depicting the levels of CRP/hs-CRP (Figure 5A), percent neutrophils (Figure 5B), fibrinogen (Figure 5C), ferritin (Figure 5D), IL-8 (Figure 5E), IL-6 (Figure 5F), and calcitonin (Figure 5G) determined over time in different patients being administered different doses of rhASM during the protocol. The right axis of the graphs depict the patient number and the dosage of rhASM.

Figure 6 is a chart of treatment emergent adverse events for four patients each on a different dose of rhASM, which events were considered to be related (possibly, probably, or definitely) to treatment.

Figure 7 is a diagram showing the primary treatment period, consisting of-dose escalation and dose maintenance phases, of the Phase 2 rhASM repeat dose protocol in patients with ASMD.

5. DETAILED DESCRIPTION OF THE INVENTION

[0059] The invention provides a recombinant human acid sphingomyelinase (rhASM) for use in a. method of treating an acid sphingomyelinase deficiency (ASMD) in a human subject in need thereof, the method comprising the following steps in the following order:

1. a. administering to the human subject at least one initial dose of 0.025 mg/kg to 0.05 mg/kg of said rhASM; and
2. b. administering to the human subject an escalating dose regimen at the following doses: (i) 0.1 mg/kg of said rhASM, (ii) 0.3 mg/kg of said rhASM, and (iii) 0.6 mg/kg of said rhASM, wherein each dose is administered at least once before elevating the dose to the

next level, and wherein each dose is administered two weeks after the administration of the previous dose.

[0060] The invention generally relates to dose escalation enzyme replacement therapy for use in a method of treating human subjects having ASMD - particularly subjects having non-neurological manifestations of NPD, and in certain embodiments, NPD type B. More particularly, the enzyme, ASM, is administered to such patients at an initial low, non-toxic dose that is then escalated in subsequent administrations. The highest dose of ASM tolerated by the patient can then be used as a maintenance dose. Alternatively, a therapeutically effective dose less than the highest dose tolerated can be used as a maintenance dose.

[0061] Treatment of NPD requires doses high enough to achieve adequate distribution of the ASM enzyme in organs of pathology (e.g., the spleen, lungs, heart, kidney and brain). Following intravenous administration of recombinant human ASM in ASMKO mice, most of the ASM activity distributes to the liver with small amounts of ASM enzymatic activity detected in other organs of pathology, such as the spleen, heart, kidney and lung (see, e.g., Figure 9B of He et al., 1999, *Biochimica et Biophysica Acta* 1432: 251-264). Thus very high doses would be required to ensure distribution and delivery of the administered enzyme to the lung, heart and kidney in patients afflicted with ASMD or Niemann-Pick disease.

[0062] Studies in an ASM knockout mouse model (ASKMO mice) showed that the majority of rhASM administered distributes to the liver and spleen where it reduces substrate, but to a much lesser extent in lungs, heart and brain (Miranda et al. *FASEB* 2000, 14:1988). In subsequent studies using higher doses of rhASM in the ASMKO mouse model, substrate was reduced and toxicity was not observed at doses ≤ 3.0 mg/kg; in fact, clinical symptoms of toxicity were not observed until doses ≥ 10 mg/kg were used. See, "Dose Responsive Toxicological Findings Following Intravenous Administration of Recombinant Human Acid Sphingomyelinase (rhASM) to Acid Sphingomyelinase Knock-out (ASKMO) Mice," C. Nickerson, J. Murray, A. Vitsky, M. Hawes, S. Ryan, P. Ewing, B. Thurberg, L. Andrews. Dept Pharm/Tox, Pathology, Genzyme Corp., Framingham, MA., *American Society of Human Genetics* 2005; and "Elevations of Pro-Inflammatory Cytokines and Decreases in Cardiovascular Hemodynamics Following Intravenous Administration of Recombinant Human Acid Sphingomyelinase (rhASM) to Acid Sphingomyelinase Knock-out (ASKMO) Mice," J. Murray, A.M. D'Angona, C. Nickerson, A. Vitsky, M. Hawes, S. Ryan, P. Ewing, B. Thurberg, L. Andrews. Dept. Pharmacology/Toxicology & Pathology, Genzyme Corp., Framingham, MA., *Society of Toxicology* 2006

[0063] Based on these ASKMO data, we treated non-neuronopathic ASMD human subjects with a conservative maximum dose of 1.0 mg/kg as described in Section 6, *infra*. Quite unexpectedly, toxicity in the human subjects, including the onset of adverse events with clinical symptoms, was observed using doses as low as 0.3 mg/kg! This result was especially surprising, since the ASM enzyme is absent in the knock out mouse model which should reflect a more severe condition than the human subjects who have at least some enzyme activity and relatively mild disease.

[0064] Without being bound by any theory, the administration of high doses of ASM to NPD patients can result in the hydrolysis of large amounts of sphingomyelin into large concentrations of ceramide, which may produce the toxic side effects observed in those NPD patients. The ASM enzyme hydrolyzes sphingomyelin, which is a major component of the plasma membrane of cells (see, e.g., Milaus et al., 2010 FEBS Letters 584: 1887-1894), into ceramide and phosphocholine. Ceramide is known to play a role in cell death and is known to be a pro-apoptotic agent (see, e.g., Smith and Schuchman, 2008, FASEB 22: 3419-3431).

[0065] Moreover, unlike other lysosomal enzymes associated with characterized lysosomal storage diseases, ASM hydrolyzes sphingomyelin at the neutral pH found in the plasma and the acidic pH found in the lysosome (see, e.g., Schissel et al., 1998. J. Biol. Chem. 273: 2738-2746). The ability of the ASM enzyme to function in the plasma can result in the hydrolysis of sphingomyelin found in lipoproteins and the plasma membrane of cells, which can increase the amount of the breakdown product, ceramide, which may cause the toxic side effects observed in NPD patients administered high doses of ASM enzyme.

[0066] To solve the problem of achieving adequate distribution of the ASM enzyme to the organs of pathology while avoiding or minimizing the toxicity associated with administering high doses of the enzyme, the inventors develop the regimens described herein, in which a low, non-toxic dose of the ASM enzyme is initially administered to a NPD patient and the dose is escalated over time. As the dose of the ASM enzyme is escalated, the patient can be monitored for total/direct/indirect bilirubin concentrations, the production of acute phase reactants, the production of inflammatory mediators, and related adverse events. The administration of a low dose of ASM and the escalation of the enzyme facilitates the debulking of the accumulated sphingomyelin. Once the patient is debulked, higher doses of the ASM enzyme may be safely administered to the patient to ensure adequate distribution of the ASM enzyme to target organs (e.g., liver, spleen, lungs, heart, kidney, brain, bone marrow, skeleton, joints, etc.). In certain embodiments, the maximum dose tolerated by the patient can be used as the maintenance dose. Alternatively, a therapeutically effective dose less than the highest dose tolerated can be used as a maintenance dose. In some embodiments, based upon a patient's condition, the maintenance dose may be increased or decreased.

[0067] In certain embodiments, treatment of the patient can be monitored by measuring the plasma sphingomyelin levels, plasma ceramide levels, the production of "acute phase reactants" and inflammatory mediators that are a measure of inflammatory responses, bilirubin concentrations (total, direct or indirect) and/or other biochemical markers to ensure a stable response before elevating the dose to the next level. These markers include, but are not limited to CRP/hs-CRP, cytokines (e.g., 1L-8, 1I-6), calcitonin, and ferritin. In specific embodiments, the patient may be monitored for one or more related adverse events which may include, but is not limited to constitutional symptoms (e.g., fever, nausea, vomiting, pain, myalgia and jaundice).

5.1. DOSE ESCALATION PROTOCOL

[0068] Methods are described for treating ASMD involving the administration of one or more initial, low non-toxic doses of ASM to a subject to reduce the amount of sphingomyelin that has accumulated in the subject. After a certain period of time, the dose of ASM can be escalated until the highest dosage tolerated by the subject that is therapeutically effective is achieved. Once this dosage is identified, it can be used as the maintenance dose to treat the subject. The maintenance dose can be administered weekly, biweekly, or monthly to the subject to treat ASMD. In some embodiments, a subject receiving a maintenance dose is monitored every 3 months, every 6 months or yearly for one, two, three or all of the following: (i) a related adverse events; (ii) total/direct/indirect bilirubin concentrations; (iii) plasma ceramide concentration; or (iv) an acute phase response. If the subject experiences a related adverse event of moderate intensity (e.g., a related moderate adverse event), a total bilirubin concentration greater than the total bilirubin value for a human without ASMD (e.g., a healthy human), a plasma ceramide concentration greater than the plasma ceramide concentration of a human without ASMD (e.g., a healthy human), or an acute phase response, then the dose administered to the subject can be evaluated by a physician or other medical professional to determine whether the dose should be adjusted.

[0069] Provided is an ASM for use in a method for treating a human subject having an acid sphingomyelinase deficiency, comprises: (a) a regimen for debulking accumulated sphingomyelin substrate in the human subject comprising: (i) administering an initial low non-toxic dose of 0.025 mg/kg to 0.05 mg/kg of ASM to the human subject; (ii) administering successively higher doses of 0.1 mg/kg, 0.3 mg/kg and 0.6 mg/kg, repeated at least once, of ASM to the human subject, and monitoring the subject for one or more adverse side effects after each successive dose as indicated by elevated bilirubin or a related adverse event; and (b) a maintenance regimen comprising administering a dose equal to or less than the highest dose tolerated by the subject as the maintenance dose for the subject. In certain aspects of the disclosure, the initial dose ranges is from 0.1 mg/kg to 0.5 mg/kg or 0.1 mg/kg to 1 mg/kg of ASM. In some embodiments, the successively higher doses are administered one, two, three or four weeks after the previous dose. In certain embodiments, the successively higher dose is approximately 0.1 mg/kg, 0.2 mg/kg, 0.3 mg/kg, 0.4 mg/kg, 0.5 mg/kg, 0.6 mg/kg, 0.7 mg/kg, 0.8 mg/kg, 0.9 mg/kg or 1 mg/kg higher than the previous dose. In some aspects, the successively higher dose is approximately 1.2 mg/kg, 1.5 mg/kg, 1.75 mg/kg, 2 mg/kg, 3 mg/kg, 4 mg/kg or 5 mg/kg higher than the previous dose. In some embodiments, the successively higher dose is 0.1 to 0.5 mg/kg, 0.1 mg/kg to 1 mg/kg or 0.5 mg/kg to 1 mg/kg higher than the previous dose. In some aspects, the successively higher dose is approximately 0.5 mg/kg to 2 mg/kg, 1 mg/kg to 2 mg/kg, 2 mg/kg to 4 mg/kg or 2 mg/kg to 5 mg/kg higher than the previous dose. In certain embodiments, the highest dose tolerated by the subject is 1 mg/kg to 2.5 mg/kg. In some embodiments, the highest dose is administered to the human subject as a maintenance dose.

[0070] Further provided is an ASM for use in a method for treating a human subject having ASMD, comprises: (a) a debulking ASM administration to reduce the amount of sphingomyelin that has accumulated in the human subject, wherein the debulking ASM administration comprises: (i) administering a low, non-toxic dose of 0.025 mg/kg to 0.05 mg/kg of ASM to the human subject; and (ii) administering successively higher doses of 0.1 mg/kg, 0.3 mg/kg and 0.6

mg/kg, repeated at least once, of ASM to the human if the human subject does not manifest one or more adverse side effects as indicated by elevated total bilirubin concentration, elevated plasma ceramide concentration, the production of acute phase reactants, the production of inflammatory mediators, or an adverse event (e.g., such as defined by the Clinical Data Interchange Standards Consortium Study Data Tabulation Model standard terminology v.3.1.1); and (b) a maintenance ASM administration, wherein the maintenance ASM administration comprises repeated administration of a maintenance dose of ASM to the human subject. In some embodiments, the patient is monitored for a period of time after administration of a dose of ASM (e.g., 6 hours, 12 hours, 16 hours, 24 hours, 48 hours, 72 hours, weekly, or up until the next dose) for one or more adverse side effects or total bilirubin. In certain embodiments, the maintenance dose that is administered may be adjusted during the course of treatment of the patient. In some embodiments, the maintenance dose administered to the subject is the highest dose tolerated by the subject.

[0071] In other aspects disclosed herein, a method for treating ASMD comprises administering to a subject in need thereof an initial low, non-toxic dose of ASM (e.g., a dose of 0.1 mg/kg, 0.2 mg/kg, 0.3 mg/kg, 0.4 mg/kg, 0.5 mg/kg, 0.6 mg/kg, 0.7 mg/kg, 0.8 mg/kg, 0.9 mg/kg, 1 mg/kg, 0.1 mg/kg to 0.5 mg/kg, or 0.5 to 1 mg/kg of ASM) and after a certain period of time (e.g., 3 days, 1 week, 2 weeks, or 3 weeks) successively increasing the dose of ASM administered to the subject until the level of ASM activity in one or more organs of pathology is at least 5%, 6%, 7%, 8%, 9%, 10%, 12%, 15%, 20%, 25%, 30%, 35%, 40%, 50%, 75%, 80%, 85%, 90%, 95% or more of the activity of ASM in the corresponding organ in a subject(s) without ASMD (e.g., a healthy subject or population of 5, 10, 15, 20, 30, 40, 50, 75, 100, 150, 175 or more subjects) as measured by techniques known in the art, such as, e.g., the technique described in He et al., 2003, Analytical Biochemistry 314: 116-120. In another aspect, a method for treating ASMD comprises administering to a subject in need thereof a dose of 0.1 mg/kg of ASM and after a certain period of time (e.g., 3 days, 1 week, 2 weeks, or 3 weeks) successively increasing the dose of ASM administered to the subject until the level of ASM activity in one or more of the following organs of pathology is 5% to 10%, 5% to 15%, 5% to 20%, 10% to 15%, 10% to 20%, 15% to 20%, 15% to 25%, 25% to 50%, 50% to 75%, or 75% to 95% of the normal activity of ASM in the corresponding organ in a subject(s) without ASMD (e.g., a healthy subject or population of 5, 10, 15, 20, 30, 40, 50, 75, 100, 150, 175 or more subjects) as measured by techniques known in the art, such as, e.g., the technique described in He et al., 2003, Analytical Biochemistry 314: 116-120. In certain embodiments, the dose is successively increased if the total bilirubin concentration is less than or equal to 2.0 mg/dL or 2.1 mg/dL and the subject does not experience a moderate or severe related adverse event. In specific embodiments, the activity of ASM in normal healthy subjects is estimated to be approximately 20 to 40 units/mg of protein for the brain, heart, kidney, and liver based upon the activity of ASM in similar organs in healthy mice using the assay described in Horinouchi et al., 1995, Nature Genetics 10: 288-293. In certain embodiments, the activity of ASM in normal healthy subjects is estimated to be approximately 15 to 25 units/mg of protein for the lung and 10 to 15 units/mg of protein for the spleen based upon the activity of ASM in similar organs in healthy mice using the assay described in Horinouchi et al., 1995, Nature Genetics 10: 288-293. In certain embodiments, once the ASM activity reaches normal or a certain percentage of normal in one or more organs

of pathology, a dose equal to or less than the highest dose tolerated by the subject can be administered to the subject as the maintenance dose. Over time, the maintenance dose may be adjusted depending on the health of the subject. Depending upon a subject's circumstances, the maintenance dose may be increased or decreased.

[0072] In one embodiment an ASM for use in a method for treating ASMD comprises: (a) administering to a human in need thereof an initial low, non-toxic dose in the range of 0.025 to 0.05 mg/kg of ASM; and (b) administering successively higher doses of 0.1 mg/kg, 0.3 mg/kg and 0.6 mg/kg, repeated at least once, of ASM if the human does not manifest one, two, three or four of the following side-effects after the administration of a dose of ASM: (i) a severe related adverse event as defined by, e.g., the Clinical Data Interchange Standards Consortium Study Data Tabulation Model standard terminology v.3.1.1; (ii) a total bilirubin value of greater than 1.5 mg/dL, 1.75 mg/dL, 2.0 mg/dL, 2.1 mg/dL, 2.2 mg/dL, 2.3 mg/dL, 2.4 mg/dL, 2.5 mg/dL, 2.6 mg/dL, 2.7 mg/dL, 2.75 mg/dL, 2.8 mg/dL, 2.9 mg/dL, 3.0 mg/dL, 3.1 mg/dL, 3.2 mg/dL, 3.3 mg/dL, 3.4 mg/dL, 3.5 mg/dL, 3.6 mg/dL, 3.7 mg/dL, 3.8 mg/dL, 3.9 mg/dL or 4 mg/dL, or in the range of 2.1 mg/dL to 2.5 mg/dL, 2.1 mg/dL to 3.0 mg/dL, or 2.1 mg/dL to 4 mg/dL that lasts for greater than 18 hours, 24 hours, 36 hours, 48 hours or 72 hours, 5 days, one week, two weeks or three weeks after administration of the dose of ASM; (iii) a plasma ceramide concentration of greater 8.2 µg/mL, 8.3 µg/mL, 8.4 µg/mL, 8.5 µg/mL, 8.75 µg/mL, 9 µg/mL, 9.5 µg/mL, 10 µg/mL, 11 µg/mL, 12 µg/mL, 13 µg/mL, 14 µg/mL, 15 µg/mL, 16 µg/mL, 17 µg/mL, 18 µg/mL, 19 µg/mL, 20 µg/mL, 25 µg/mL, 30 µg/mL, 35 µg/mL, 40 µg/mL, 45 µg/mL, 50 µg/mL, 55 µg/mL, 60 µg/mL, 65 µg/mL, 70 µg/mL, 75 µg/mL, or 80 µg/mL, or in the range of 8.2 µg/mL to 10 µg/mL, 8.5 µg/mL to 10 µg/mL, 9 µg/mL to 12 µg/mL, 10 µg/mL to 12 µg/mL, 10 µg/mL to 15 µg/mL, 10 µg/mL to 20 µg/mL, 15 µg/mL to 20 µg/mL, or 20 µg/mL to 30 µg/mL 6 hours, 8 hours, 10 hours, 12 hours, 16 hours, 18 hours, 24 hours, 36 hours, 48 hours or 72 hours after administration of the dose of ASM; or (iv) an acute phase response. In accordance with this embodiment, the human in need thereof can be administered successively higher doses of ASM so long the human does not manifest any one or more of items (i) to (iv). In the event that the human manifests any one or more of items (i) to (iv), then depending on the severity the manifestation, the same dose that resulted in the manifestation of items (i) to (iv) may be repeated or the dose may be decreased to the previous dose.

[0073] Further disclosed is a method for treating ASMD comprises: (a) administering to a human in need thereof an initial dose of 0.1 mg/kg of ASM; (b) monitoring one or more of the following in the human subsequent to the administration of the dose of ASM: (i) total bilirubin concentration, (ii) the manifestation of a related adverse event; (iii) an acute phase response; or (iv) plasma ceramide concentration; (c) determining whether to adjust (e.g., increase or decrease) or maintain the dose of ASM based on one or more of items (i) to (iv); and (d) repeating steps (b) and (c) following the administration of the dose of ASM determined in the previous step (c). Further disclosed a method for treating ASMD comprises: (a) administering to a human in need thereof two initial doses of 0.1 mg/kg of ASM 2 to 4 weeks apart; (b) monitoring one or more of the following in the human subsequent to the administration of each dose of ASM: (i) total bilirubin concentration, (ii) the manifestation of a related adverse event; (iii) an acute phase response; or (iv) plasma ceramide concentration; (c) determining whether to adjust (e.g., increase or decrease) or maintain the dose of ASM based on one or more of items

(i) to (iv); and (d) repeating steps (b) and (c) following the administration of the dose of ASM determined in the previous step (c). In accordance with this disclosure, the human can be administered a higher dose of ASM one or more times 2 to 4 weeks apart if the initial dose of 0.1 mg/kg or the adjusted dose determined in step (c) results in: (i) a total bilirubin concentration of less than or equal to 2.0 mg/dL before the deadline for administering another dose of ASM; (ii) no related adverse events or only mild related adverse events; (iii) a plasma ceramide within the normal range 6 hours, 8 hours, 12 hours, 16 hours, 18 hours, 24 hours, 48 hours, or 72 hours administration the last dose of ASM; or (iv) no acute phase response or an acute phase response that is not statistically significant. However, the dose can be maintained or decreased if the initial dose of 0.1 mg/kg or the adjusted dose determined in step (c) results in: (i) a total bilirubin concentration of 2.1 mg/dL or greater before the deadline for administering another dose of ASM; (ii) a related adverse event; (iii) a plasma ceramide above the normal range 6 hours, 8 hours, 12 hours, 16 hours, 18 hours, 24 hours, 48 hours, or 72 hours administration the last dose of ASM; or (iv) an acute phase response that is statistically significant.

[0074] Further disclosed is a method for treating ASMD comprises: (A) administering to a human in need thereof two initial doses of 0.1 mg/kg 2 weeks apart; (B) monitoring either (i) total bilirubin concentration, (ii) the manifestation of a related adverse event, (iii) both (i) and (ii) in the human subsequent to the administration of each initial dose of ASM; (C) determining whether to adjust (e.g., increase or decrease) or maintain the dose of ASM based on one or more of items (i) to (iii), and (D) repeating steps (B) and (C) following the administration of the dose of ASM determined in the previous step (C), wherein (a) the dose administered to the human is increased if the total bilirubin concentration is less than or equal to 2.0 mg/dL or the human presents with a mild related adverse event; (b) the human continues to receive the current dose 1 to 4 times 2 to 4 weeks apart if the total bilirubin concentration is 2.1 mg/dL to 3.1 mg/dL or the human presents with a moderate related adverse event and this dose is maintained if the total bilirubin concentration remains greater than 2.0 mg/dL subsequent to the last administered dose; (c) the dose administered to the human is decreased or no longer administered ASM if the total bilirubin concentration is greater than 3 mg/dL or the human presents with severe related adverse events.

[0075] In another aspect, a method for treating ASMD comprises: (A) administering to a human in need thereof two initial doses of 0.3 mg/kg 2 weeks apart; (B) monitoring either (i) total bilirubin concentration, (ii) the manifestation of a related adverse event, (iii) both (i) and (ii) in the human subsequent to the administration of each dose of ASM; (C) determining whether to adjust (e.g., increase or decrease) or maintain the dose of ASM based on one or more of items (i) to (iii), and (D) repeating steps (B) and (C) following the administration of the dose of ASM determined in the previous step (C), wherein (a) the dose administered to the human is increased if the total bilirubin concentration is less than or equal to 2.0 mg/dL or the human presents with a mild related adverse event; (b) the human continues to receive the current dose 1 to 4 times 2 to 4 weeks apart if the total bilirubin concentration is 2.1 mg/dL to 3.1 mg/dL or the human presents with a moderate related adverse event and this dose is maintained if the total bilirubin concentration remains greater than 2.0 mg/dL subsequent to the last administered dose; (c) the dose administered to the human is decreased or no longer administered ASM if

the total bilirubin concentration is greater than 3 mg/dL or the human presents with severe related adverse events.

[0076] In a specific embodiment, an ASM for use in a method for treating ASMD comprises administering to a subject in need thereof a dose of 0.1 mg/kg of ASM and after two weeks a dose of 0.3 mg/kg of ASM every two weeks. In another specific embodiment, the method for treating ASMD comprises administering to a subject in need thereof a dose of 0.1 mg/kg of ASM, a dose of 0.3 mg/kg of ASM two weeks after the administration of the 0.1 mg/kg dose of ASM, and a dose of 0.6 mg/kg of ASM two weeks after the administration of the dose of 0.3 mg/kg of ASM. In another specific embodiment, an ASM for use in a method for treating ASMD comprises administering to a subject in need thereof a dose of 0.1 mg/kg of ASM, a dose of 0.3 mg/kg of ASM two weeks after the administration of the 0.1 mg/kg dose of ASM, a dose of 0.6 mg/kg of ASM two weeks after the administration of the dose of 0.3 mg/kg of ASM, and a dose of 1 mg/kg of ASM two weeks after the administration of the dose of 0.6 mg/kg of ASM. In certain embodiments, each dose may be repeated at least two, and preferably two to four times before escalating the dose to the next level. In accordance with these embodiments, the dose is only escalated if the total bilirubin value is equal to or less than 2.0 mg/dL and/or the subject experiences a mild related adverse event. The dose is not escalated if the total bilirubin value is between 2.1 and 3 mg/dL and/or the subject experiences a moderate related adverse event. The dose is reduced to a previously tolerated dose if the total bilirubin value is greater than 3.0 mg/dL of total bilirubin and/or the subject experiences a serious related adverse event.

[0077] In specific embodiments, a patient is treated for ASMD in accordance with the protocol described in Section 8 or 9 *et seq.*, *infra*, or an analogous protocol.

[0078] In some cases, a method for treating ASMD comprises administering to a subject in need thereof a dose of 0.1 mg/kg, 0.2 mg/kg, 0.3 mg/kg, 0.4 mg/kg, 0.5 mg/kg., 0.6 mg/kg, 0.7 mg/kg, 0.8 mg/kg, 0.9 mg/kg, 1 mg/kg, or 0.1 mg/kg to 0.5 mg/kg, or 0.1 mg/kg to 1 mg/kg of ASM and after a certain period of time (*e.g.*, 3 days, 1 week, 2 weeks, 3 weeks or 4 weeks) successively increasing the dose of ASM administered to the subject if total bilirubin concentration is less than or equal to 2.1 mg/dL and the subject does not experience a moderate or severe related adverse event. In some embodiments, the dose of ASM is successively increased until the maximum or highest dose tolerated by the subject which is therapeutically effective is achieved. In certain embodiments, such highest or maximum dose tolerated is administered until such time as the accumulated sphingomyelin in the organs of pathology is debulked after which a maintenance dose that is lower than the maximum dose tolerated which is still therapeutically effective is administered to the subject. In some embodiments, the maintenance dose is scaled back over time as the patient's condition improves.

[0079] In a specific embodiment, the highest dose tolerated that is therapeutically effective is the highest dosage that is effective in the treatment of ASMD without causing one, two or more severe related adverse events or related adverse events as defined by, *e.g.*, the Clinical Data Interchange Standards Consortium Study Data Tabulation Model standard terminology v.3.1.1. In another embodiment, the highest dose tolerated that is therapeutically effective is the highest dosage that is effective in the treatment of ASMD without causing an increase in the total

bilirubin concentration relative to a patient's total bilirubin concentration prior to administration of ASM, which increase lasts for greater than two days, three days, five days, one week, two weeks, or three weeks. In another embodiment, the highest dose tolerated that is therapeutically effective is the highest dosage that is effective in the treatment of ASMD without causing a total bilirubin concentration of greater than normal total bilirubin concentrations that lasts for greater than 18 hours, 24 hours, 36 hours, 48 hours or 72 hours, 5 days, one week, two weeks or three weeks after administration of the dose of ASM. The normal total bilirubin concentration in a human without ASMD (e.g., a healthy human) is less than approximately 1.2 mg/dL. In certain embodiments, the highest dose tolerated that is therapeutically effective is the highest dosage that is effective in the treatment of ASMD without causing a total bilirubin concentration that is greater than approximately 1.5 mg/dL, 1.75 mg/dL, 2.0 mg/dL, 2.1 mg/dL, 2.2 mg/dL, 2.3 mg/dL, 2.4 mg/dL, 2.5 mg/dL, 2.6 mg/dL, 2.7 mg/dL, 2.75 mg/dL, 2.8 mg/dL, 2.9 mg/dL, 3.0 mg/dL, 3.1 mg/dL, 3.2 mg/dL, 3.3 mg/dL, 3.4 mg/dL, 3.5 mg/dL, 3.6 mg/dL, 3.7 mg/dL, 3.8 mg/dL, 3.9 mg/dL or 4 mg/dL or in the range of 2.1 mg/dL to 2.5 mg/dL, 2.1 mg/dL to 3.0 mg/dL, or 2.1 mg/dL to 4 mg/dL that lasts for greater than 18 hours, 24 hours, 36 hours, 48 hours or 72 hours, 5 days, one week, two weeks or three weeks after administration of the dose of ASM.

[0080] In another embodiment, the highest dose tolerated is the highest dosage that is effective in the treatment of ASMD without resulting in a plasma ceramide concentration that is greater than the normal plasma ceramide concentration 6 hours, 8 hours, 12 hours, 16 hours, 18 hours, 24 hours, 36 hours, 48 hours or 72 hours after administration of the dose of ASM. The normal plasma ceramide concentration in a human without ASMD (e.g., a healthy human) is approximately 1.5 to 8 µg/mL. In certain embodiments, the highest dose tolerated is the highest dosage that is effective in the treatment of ASMD without resulting in a plasma ceramide concentration of greater than approximately 8.2 µg/mL, 8.3 µg/mL, 8.4 µg/mL, 8.5 µg/mL, 8.75 µg/mL, 9 µg/mL, 9.5 µg/mL, 10 µg/mL, 11 µg/mL, 12 µg/mL, 13 µg/mL, 14 µg/mL, 15 µg/mL, 16 µg/mL, 17 µg/mL, 18 µg/mL, 19 µg/mL, 20 µg/mL, 25 µg/mL, 30 µg/mL, 35 µg/mL, 40 µg/mL, 45 µg/dm, 50 µg/mL, 55 µg/mL, 60 µg/mL, 65 µg/mL, 70 µg/mL, 75 µg/mL, or 80 µg/mL, or in the range of 8.2 µg/mL to 10 µg/mL, 8.5 µg/mL to 10 µg/mL, 9 µg/mL to 12 µg/mL, 10 µg/mL to 12 µg/mL, 10 µg/mL to 15 µg/mL, 10 µg/mL to 20 µg/mL, 15 µg/mL to 20 µg/mL, or 20 µg/mL to 30 µg/mL 6 hours, 8 hours, 10 hours, 12 hours, 16 hours, 18 hours, 24 hours, 36 hours, 48 hours or 72 hours after administration of the dose of ASM.

[0081] In another embodiment, the highest dose tolerated that is therapeutically effective is the highest dosage that is effective in the treatment of ASMD without causing an acute phase response. An acute phase response can be assessed by a change in the concentration of an acute phase reactant, a change in prothrombin time, a change in partial thromboplastin time, or a change in the percentage of neutrophils. For example, an acute phase response can be assessed by an increase in one or more of the following factors following ASM administration to subject relative to those factors prior to administration of ASM to the subject or relative to those factors in a human without ASMD (e.g., a healthy human): the percentage of neutrophils, the prothrombin time (PT), the partial thromboplastin time (PTT), the total bilirubin concentration, C-reactive protein (CRP/hs-CRP) concentration, serum amyloid A (SAA), serum amyloid P

component, angiotensin converting enzyme (ACE), ferritin concentration, IL-6 concentration, IL-8 concentration, calcitonin concentration, albumin concentration, or fibrinogen concentration. An acute phase response can also be assessed by a decrease in iron concentration or albumin concentration following ASM administration to a subject relative to the iron concentration or albumin concentration in the subject prior to ASM administration or relative to the iron concentration or albumin concentration in a human without ASMD (e.g., a healthy human).

[0082] In a specific embodiment, the highest dose tolerated that is therapeutically effective is the highest dosage that is effective in the treatment of ASMD without causing an increase in CRP/hs-CRP concentration 6 hours, 8 hours, 12 hours, 16 hours, 18 hours, 24 hours, 36 hours, 48 hours or 72 hours after administration of the dose of ASM relative to a patient's CRP/hs-CRP concentration prior to administration of ASM. In another specific embodiment, the highest dose tolerated that is therapeutically effective is the highest dosage that is effective in the treatment of ASMD without resulting in a plasma CRP/hs-CRP concentration that is greater than the normal plasma CRP/hs-CRP concentration 6 hours, 8 hours, 12 hours, 16 hours, 18 hours, 24 hours, 36 hours, 48 hours or 72 hours after administration of the dose of ASM. The normal plasma CRP/hs-CRP concentration in a human without ASMD (e.g., a healthy human) is less than approximately 8 mg/L. In certain embodiments, the highest dose tolerated that is therapeutically effective is the highest dosage that is effective in the treatment of ASMD without causing a plasma CRP/hs-CRP concentration of greater than approximately 8.1 mg/L, 8.2 mg/L, 8.3 mg/L, 8.4 mg/L, 8.5 mg/L, 8.6 mg/L, 8.7 mg/L, 8.8 mg/L, 8.8 mg/L, 8.9 mg/L, 9 mg/L, 9.5 mg/L, 10 mg/L, 11 mg/L, or 12 mg/L, or in the range of 8.5 mg/L to 10 mg/L, or 8.5 mg/L to 12 mg/L, or 10 mg/L to 12 mg/L 6 hours, 8 hours, 12 hours, 16 hours, 18 hours, 24 hours, 36 hours, 48 hours or 72 hours after administration of the dose of ASM.

[0083] In a specific embodiment, the highest dose tolerated that is therapeutically effective is the highest dosage that is effective in the treatment of ASMD without causing an increase in ferritin concentration 6 hours, 8 hours, 12 hours, 16 hours, 18 hours, 24 hours, 36 hours, 48 hours or 72 hours after administration of the dose of ASM relative to a patient's ferritin concentration prior to administration of ASM. In another specific embodiment, the highest dose tolerated that is therapeutically effective is the highest dosage that is effective in the treatment of ASMD without resulting in a plasma ferritin concentration that is greater than the normal plasma ferritin concentration 6 hours, 8 hours, 12 hours, 16 hours, 18 hours, 24 hours, 36 hours, 48 hours or 72 hours after administration of the dose of ASM. The normal plasma ferritin concentration in a human without ASMD (e.g., a healthy human) is 10 to 30 ng/mL. In certain embodiments, the highest dose tolerated that is therapeutically effective is the highest dosage that is effective in the treatment of ASMD without causing a plasma ferritin concentration of greater than approximately 300 ng/mL, 325 ng/mL, 350 ng/mL, 375 ng/mL, 400 ng/mL, 425 ng/mL, 450 ng/mL, 475 ng/mL, 500 ng/mL, 525 ng/mL, 550 ng/mL, 575 ng/mL, 600 ng/mL, 625 ng/mL, 650 ng/mL, 675 ng/mL, 700 ng/mL, 725 ng/mL, 750 ng/mL, 775 ng/mL, 800 ng/mL, 850 ng/mL, 900 ng/mL, 950 ng/mL, 1000 ng/mL, 1050 ng/mL, 1100 ng/mL, 1150 ng/mL, or 1200 ng/mL or in the range of 600 ng/mL to 800 ng/mL, 650 ng/mL to 850 ng/mL, 600 ng/mL to 1000 ng/mL, 600 ng/mL to 1200 ng/mL, 800 ng/mL to 1000 ng/mL, 900 ng/mL to 1000 ng/mL, or 1000 ng/mL, or 1000 ng/mL to 1200 ng/mL 6 hours, 8 hours, 12 hours, 16 hours, 18 hours, 24 hours, 36 hours, 48 hours or 72 hours after administration of the dose of ASM can be used as a

measurement of an acute phase response.

[0084] In a specific embodiment, an increase in plasma or serum IL-8 concentration 6 hours, 8 hours, 12 hours, 16 hours, 18 hours, 24 hours, 36 hours, 48 hours or 72 hours after administration of a dose of ASM relative to a patient's IL-8 concentration prior to administration of ASM can be used as a measurement of an acute phase response. In another specific embodiment, a plasma or serum IL-8 concentration that is greater than the normal plasma IL-8 concentration 6 hours, 8 hours, 12 hours, 18 hours, 24 hours, 36 hours, 48 hours or 72 hours after administration of the dose of ASM can be used as a measurement of an acute phase response. In certain embodiments, a plasma IL-8 concentration of greater than approximately 24 pg/mL, 50 pg/mL, 75 pg/mL, 100 pg/mL, 200 pg/mL, 300 pg/mL, 400 pg/mL, 500 pg/mL, 600 pg/mL, 700 pg/mL, 800 pg/mL, or 900 pg/mL 6 hours, 8 hours, 12 hours, 16 hours, 18 hours, 24 hours, 36 hours, 48 hours or 72 hours after administration of the dose of ASM can be used as a measurement of an acute phase response.

[0085] In a specific embodiment, an increase in plasma or serum IL-6 concentration 6 hours, 8 hours, 12 hours, 16 hours, 18 hours, 24 hours, 36 hours, 48 hours or 72 hours after administration of a dose of ASM relative to a patient's IL-6 concentration prior to administration of ASM can be used as a measurement of an acute phase response. In another specific embodiment, a plasma or serum IL-6 concentration that is greater than the normal plasma or serum IL-6 concentration 6 hours, 8 hours, 12 hours, 18 hours, 24 hours, 36 hours, 48 hours or 72 hours after administration of the dose of ASM can be used as a measurement of an acute phase response. In certain embodiments, a plasma IL-6 concentration of greater than approximately 4.4 pg/mL, 6 pg/mL, 8 pg/mL, 10 pg/mL, 15 pg/mL, 20 pg/mL, 25 pg/mL, or 30 pg/mL 6 hours, 8 hours, 12 hours, 16 hours, 18 hours, 24 hours, 36 hours, 48 hours or 72 hours after administration of the dose of ASM can be used as a measurement of an acute phase response.

[0086] In a specific embodiment, an increase in plasma or serum calcitonin concentration 6 hours, 8 hours, 12 hours, 16 hours, 18 hours, 24 hours, 36 hours, 48 hours or 72 hours after administration of a dose of ASM relative to a patient's calcitonin concentration prior to administration of ASM can be used as a measurement of an acute phase response. In another specific embodiment, a plasma or serum calcitonin concentration that is greater than the normal plasma calcitonin concentration 6 hours, 8 hours, 12 hours, 18 hours, 24 hours, 36 hours, 48 hours or 72 hours after administration of the dose of ASM can be used as a measurement of an acute phase response. In certain embodiments, a plasma calcitonin concentration of greater than approximately 9.4 pg/mL, 20 pg/mL, 30 pg/mL, 40 pg/mL, 50 pg/mL, 75 pg/mL, 100 pg/mL, 150 pg/mL, 200 pg/mL, or 250 pg/mL, 6 hours, 8 hours, 12 hours, 16 hours, 18 hours, 24 hours, 36 hours, 48 hours or 72 hours after administration of the dose of ASM can be used as a measurement of an acute phase response.

[0087] In a specific embodiment, the highest dose tolerated that is therapeutically effective is the highest dosage that is effective in the treatment of ASMD without causing an increase in fibrinogen concentration 6 hours, 8 hours, 12 hours, 18 hours, 24 hours, 36 hours, 48 hours or

72 hours after administration of the dose of ASM relative to a patient's fibrinogen concentration prior to administration of ASM. In another specific embodiment, the highest dose tolerated that is therapeutically effective is the highest dosage that is effective in the treatment of ASMD without resulting in a plasma fibrinogen concentration that is greater than the normal plasma fibrinogen concentration 6 hours, 8 hours, 12 hours, 16 hours, 18 hours, 24 hours, 36 hours, 48 hours or 72 hours after administration of the dose of ASM. The normal plasma fibrinogen concentration in a human without ASMD (e.g., a healthy human) is 150 mg/dL to 300 mg/dL. In certain embodiments, the highest dose tolerated that is therapeutically effective is the highest dosage that is effective in the treatment of ASMD without causing a plasma fibrinogen concentration of greater than approximately 350 mg/dL, 375 mg/dL, 400 mg/dL, 425 mg/dL, or 450 mg/dL, or in the range of 350 mg/dL to 400 mg/dL, 350 mg/dL to 450 mg/dL or 400 mg/dL to 450 mg/dL, 6 hours, 8 hours, 12 hours, 16 hours, 18 hours, 24 hours, 36 hours, 48 hours or 72 hours after administration of the dose of ASM.

[0088] In a specific aspect, the highest dose tolerated that is therapeutically effective is the highest dosage that is effective in the treatment of ASMD without causing an increase in the percentage of neutrophils of total white blood cells 6 hours, 8 hours, 12 hours, 16 hours, 18 hours, 24 hours, 36 hours, 48 hours or 72 hours after administration of the dose of ASM relative to a patient's percentage of neutrophils of total white blood cells prior to administration of ASM. In another specific aspect, the highest dose tolerated that is therapeutically effective is the highest dosage that is effective in the treatment of ASMD without resulting in a percentage of neutrophils of total white blood cells that is greater than the normal percentage of neutrophils of total white blood cells concentration 6 hours, 8 hours, 12 hours, 16 hours, 18 hours, 24 hours, 36 hours, 48 hours or 72 hours after administration of the dose of ASM. The normal percentage of neutrophils of total white blood cells in a human without ASMD (e.g., a healthy human) is 45 % to 60%. In certain aspects, the highest dose tolerated that is therapeutically effective is the highest dosage that is effective in the treatment of ASMD without causing an increase in the percentage of neutrophils of total white blood cells that is 70%, 75%, 80%, 85%, 90%, 95% or greater 6 hours, 8 hours, 12 hours, 18 hours, 24 hours, 36 hours, 48 hours or 72 hours after administration of the dose of ASM.

[0089] In another embodiment, the highest dose tolerated that is therapeutically effective is the highest dosage that is effective in the treatment of ASMD without causing an increase in antibodies to the administered ASM. In another embodiment, the highest dose tolerated that is therapeutically effective is the highest dosage that is effective in the treatment of ASMD without causing a hypersensitivity reaction. In another embodiment, the highest dose tolerated that is therapeutically effective is the highest dosage that is effective in the treatment of ASMD without causing cytokine release syndrome.

[0090] In certain embodiments, the highest dose tolerated by a subject that is therapeutically effective is 1 mg/kg to 2.5 mg/kg, 2 mg/kg to 3 mg/kg, 3 mg/kg to 5 mg/kg, 5 mg/kg to 10 mg/kg, 10 mg/kg to 15 mg/kg, 15 mg/kg to 20 mg/kg, 15 mg/kg to 25 mg/kg, 20 mg/kg to 30 mg/kg, or 25 mg/kg to 50 mg/kg. In some embodiments, the highest dose tolerated by a subject that is therapeutically effective is 1 mg/kg, 2 mg/kg, 3 mg/kg, 4 mg/kg, 5 mg/kg, 6 mg/kg, 7 mg/kg, 8 mg/kg, 9 mg/kg, 10 mg/kg, 11 mg/kg, 12 mg/kg, 13 mg/kg, 14 mg/kg, or 15 mg/kg. In certain

embodiments, the highest dose tolerated by a subject that is therapeutically effective is 20 mg/kg, 25 mg/kg, 30 mg/kg, 35 mg/kg, 40 mg/kg, 45 mg/kg, or 50 mg/kg.

[0091] In a specific embodiment, the highest dose tolerated that is therapeutically effective is the highest dosage that is effective in the treatment of ASMD without causing one, two or more severe related adverse events or related adverse events as defined by, *e.g.*, the Clinical Data Interchange Standards Consortium Study Data Tabulation Model standard terminology v.3.1.1. In another embodiment, the highest dose tolerated that is therapeutically effective is the highest dosage that is effective in the treatment of ASMD without causing an increase in the total bilirubin concentration relative to a patient's total bilirubin concentration prior to administration of ASM, which increase lasts for greater than two days, three days, five days, one week, two weeks, or three weeks. In another embodiment, the highest dose tolerated that is therapeutically effective is the highest dosage that is effective in the treatment of ASMD without causing a total bilirubin concentration of greater than normal total bilirubin concentrations that lasts for greater than 18 hours, 24 hours, 36 hours, 48 hours or 72 hours, 5 days, one week, two weeks or three weeks after administration of the dose of ASM. The normal total bilirubin concentration in a human without ASMD (*e.g.*, a healthy human) is less than approximately 1.2 mg/dL. In certain embodiments, the highest dose tolerated that is therapeutically effective is the highest dosage that is effective in the treatment of ASMD without causing a total bilirubin concentration that is greater than approximately 1.5 mg/dL, 1.75 mg/dL, 2.0 mg/dL, 2.1 mg/dL, 2.2 mg/dL, 2.3 mg/dL, 2.4 mg/dL, 2.5 mg/dL, 2.6 mg/dL, 2.7 mg/dL, 2.75 mg/dL, 2.8 mg/dL, 2.9 mg/dL, 3.0 mg/dL, 3.1 mg/dL, 3.2 mg/dL, 3.3 mg/dL, 3.4 mg/dL, 3.5 mg/dL, 3.6 mg/dL, 3.7 mg/dL, 3.8 mg/dL, 3.9 mg/dL or 4 mg/dL or in the range of 2.1 mg/dL to 2.5 mg/dL, 2.1 mg/dL to 3.0 mg/dL, or 2.1 mg/dL to 4 mg/dL that lasts for greater than 18 hours, 24 hours, 36 hours, 48 hours or 72 hours, 5 days, one week, two weeks or three weeks after administration of the dose of ASM.

[0092] In another embodiment, the highest dose tolerated is the highest dosage that is effective in the treatment of ASMD without resulting in a plasma ceramide concentration that is greater than the normal plasma ceramide concentration 6 hours, 8 hours, 12 hours, 16 hours, 18 hours, 24 hours, 36 hours, 48 hours or 72 hours after administration of the dose of ASM. The normal plasma ceramide concentration in a human without ASMD (*e.g.*, a healthy human) is approximately 1.5 to 8 µg/mL. In certain embodiments, the highest dose tolerated is the highest dosage that is effective in the treatment of ASMD without resulting in a plasma ceramide concentration of greater than approximately 8.2 µg/mL, 8.3 µg/mL, 8.4 µg/mL, 8.5 µg/mL, 8.75 µg/mL, 9 µg/mL, 9.5 µg/mL, 10 µg/mL, 11 µg/mL, 12 µg/mL, 13 µg/mL, 14 µg/mL, 15 µg/mL, 16 µg/mL, 17 µg/mL, 18 µg/mL, 19 µg/mL, 20 µg/mL, 25 µg/mL, 30 µg/mL, 35 µg/mL, 40 µg/mL, 45 µg/mL, 50 µg/mL, 55 µg/mL, 60 µg/mL, 65 µg/mL, 70 µg/mL, 75 µg/mL, or 80 µg/mL, or in the range of 8.2 µg/mL to 10 µg/mL, 8.5 µg/mL to 10 µg/mL, 9 µg/mL to 12 µg/mL, 10 µg/mL to 12 µg/mL, 10 µg/mL to 15 µg/mL, 10 µg/mL to 20 µg/mL, 15 µg/mL to 20 µg/mL, or 20 µg/mL to 30 µg/mL 6 hours, 8 hours, 10 hours, 12 hours, 16 hours, 18 hours, 24 hours, 36 hours, 48 hours or 72 hours after administration of the dose of ASM.

[0093] In another embodiment, the highest dose tolerated that is therapeutically effective is the

highest dosage that is effective in the treatment of ASMD without causing an acute phase response. An acute phase response can be assessed by a change in the concentration of an acute phase reactant, a change in prothrombin time, a change in partial thromboplastin time, or a change in the percentage of neutrophils. For example, an acute phase response can be assessed by an increase in one or more of the following factors following ASM administration to subject relative to those factors prior to administration of ASM to the subject or relative to those factors in a human without ASMD (e.g., a healthy human): the percentage of neutrophils, the prothrombin time (PT), the partial thromboplastin time (PTT), the total bilirubin concentration, C-reactive protein (CRP/hs-CRP) concentration, serum amyloid A (SAA), serum amyloid P component, angiotensin converting enzyme (ACE), ferritin concentration, albumin concentration or fibrinogen concentration. An acute phase response can also be assessed by a decrease in iron concentration or albumin concentration following ASM administration to a subject relative to the iron concentration or albumin concentration in the subject prior to ASM administration or relative to the iron concentration or albumin concentration in a human without ASMD (e.g., a healthy human).

[0094] In a specific embodiment, the highest dose tolerated that is therapeutically effective is the highest dosage that is effective in the treatment of ASMD without causing an increase in CRP/hs-CRP concentration 6 hours, 8 hours, 12 hours, 16 hours, 18 hours, 24 hours, 36 hours, 48 hours or 72 hours after administration of the dose of ASM relative to a patient's CRP/hs-CRP concentration prior to administration of ASM. In another specific embodiment, the highest dose tolerated that is therapeutically effective is the highest dosage that is effective in the treatment of ASMD without resulting in a plasma CRP/hs-CRP concentration that is greater than the normal plasma CRP/hs-CRP concentration 6 hours, 8 hours, 12 hours, 16 hours, 18 hours, 24 hours, 36 hours, 48 hours or 72 hours after administration of the dose of ASM. The normal plasma CRP/hs-CRP concentration in a human without ASMD (e.g., a healthy human) is less than approximately 8 mg/L. In certain embodiments, the highest dose tolerated that is therapeutically effective is the highest dosage that is effective in the treatment of ASMD without causing a plasma CRP/hs-CRP concentration of greater than approximately 8.1 mg/L, 8.2 mg/L, 8.3 mg/L, 8.4 mg/L, 8.5 mg/L, 8.6 mg/L, 8.7 mg/L, 8.8 mg/L, 8.8 mg/L, 8.9 mg/L, 9 mg/L, 9.5 mg/L, 10 mg/L, 11 mg/L, or 12 mg/L, or in the range of 8.5 mg/L to 10 mg/L, or 8.5 mg/L to 12 mg/L, or 10 mg/L to 12 mg/L 6 hours, 8 hours, 12 hours, 16 hours, 18 hours, 24 hours, 36 hours, 48 hours or 72 hours after administration of the dose of ASM.

[0095] In a specific embodiment, the highest dose tolerated that is therapeutically effective is the highest dosage that is effective in the treatment of ASMD without causing an increase in ferritin concentration 6 hours, 8 hours, 12 hours, 16 hours, 18 hours, 24 hours, 36 hours, 48 hours or 72 hours after administration of the dose of ASM relative to a patient's ferritin concentration prior to administration of ASM. In another specific embodiment, the highest dose tolerated that is therapeutically effective is the highest dosage that is effective in the treatment of ASMD without resulting in a plasma ferritin concentration that is greater than the normal plasma ferritin concentration 6 hours, 8 hours, 12 hours, 16 hours, 18 hours, 24 hours, 36 hours, 48 hours or 72 hours after administration of the dose of ASM. The normal plasma ferritin concentration in a human without ASMD (e.g., a healthy human) is 10 to 30 ng/mL. In certain embodiments, the highest dose tolerated that is therapeutically effective is the highest dosage

that is effective in the treatment of ASMD without causing a plasma ferritin concentration of greater than approximately 600 ng/mL, 625 ng/mL, 650 ng/mL, 675 ng/mL, 700 ng/mL, 725 ng/mL, 750 ng/mL, 775 ng/mL, 800 ng/mL, 850 ng/mL, 900 ng/mL, 950 ng/mL, 1000 ng/mL, 1050 ng/mL, 1100 ng/mL, 1150 ng/mL, or 1200 ng/mL or in the range of 600 ng/mL to 800 ng/mL, 650 ng/mL to 850 ng/mL, 600 ng/mL to 1000 ng/mL, 600 ng/mL to 1200 ng/mL, 800 ng/mL to 1000 ng/mL, 900 ng/mL to 1000 ng/mL, or 1000 ng/mL to 1200 ng/mL 6 hours, 8 hours, 12 hours, 16 hours, 18 hours, 24 hours, 36 hours, 48 hours or 72 hours after administration of the dose of ASM.

[0096] In a specific embodiment, the highest dose tolerated that is therapeutically effective is the highest dosage that is effective in the treatment of ASMD without causing an increase in fibrinogen concentration 6 hours, 8 hours, 12 hours, 18 hours, 24 hours, 36 hours, 48 hours or 72 hours after administration of the dose of ASM relative to a patient's fibrinogen concentration prior to administration of ASM. In another specific embodiment, the highest dose tolerated that is therapeutically effective is the highest dosage that is effective in the treatment of ASMD without resulting in a plasma fibrinogen concentration that is greater than the normal plasma fibrinogen concentration 6 hours, 8 hours, 12 hours, 16 hours, 18 hours, 24 hours, 36 hours, 48 hours or 72 hours after administration of the dose of ASM. The normal plasma fibrinogen concentration in a human without ASMD (*e.g.*, a healthy human) is 150 mg/dL to 300 mg/dL. In certain embodiments, the highest dose tolerated that is therapeutically effective is the highest dosage that is effective in the treatment of ASMD without causing a plasma fibrinogen concentration of greater than approximately 350 mg/dL, 375 mg/dL, 400 mg/dL, 425 mg/dL, or 450 mg/dL, or in the range of 350 mg/dL to 400 mg/dL, 350 mg/dL to 450 mg/dL or 400 mg/dL to 450 mg/dL, 6 hours, 8 hours, 12 hours, 16 hours, 18 hours, 24 hours, 36 hours, 48 hours or 72 hours after administration of the dose of ASM.

[0097] In a specific embodiment, the highest dose tolerated that is therapeutically effective is the highest dosage that is effective in the treatment of ASMD without causing an increase in the percentage of neutrophils of total white blood cells 6 hours, 8 hours, 12 hours, 16 hours, 18 hours, 24 hours, 36 hours, 48 hours or 72 hours after administration of the dose of ASM relative to a patient's percentage of neutrophils of total white blood cells prior to administration of ASM. In another specific embodiment, the highest dose tolerated that is therapeutically effective is the highest dosage that is effective in the treatment of ASMD without resulting in a percentage of neutrophils of total white blood cells that is greater than the normal percentage of neutrophils of total white blood cells concentration 6 hours, 8 hours, 12 hours, 16 hours, 18 hours, 24 hours, 36 hours, 48 hours or 72 hours after administration of the dose of ASM. The normal percentage of neutrophils of total white blood cells in a human without ASMD (*e.g.*, a healthy human) is 45 % to 60%. In certain aspects, the highest dose tolerated that is therapeutically effective is the highest dosage that is effective in the treatment of ASMD without causing an increase in the percentage of neutrophils of total white blood cells that is 70%, 75%, 80%, 85%, 90%, 95% or greater 6 hours, 8 hours, 12 hours, 18 hours, 24 hours, 36 hours, 48 hours or 72 hours after administration of the dose of ASM.

[0098] In another embodiment, the highest dose tolerated that is therapeutically effective is the

highest dosage that is effective in the treatment of ASMD without causing an increase in antibodies to the administered ASM. In another embodiment, the highest dose tolerated that is therapeutically effective is the highest dosage that is effective in the treatment of ASMD without causing a hypersensitivity reaction. In another embodiment, the highest dose tolerated that is therapeutically effective is the highest dosage that is effective in the treatment of ASMD without causing cytokine release syndrome.

[0099] In certain embodiments, the highest dose tolerated by a subject that is therapeutically effective is 1 mg/kg to 2.5 mg/kg, 2 mg/kg to 3 mg/kg, 3 mg/kg to 5 mg/kg, 5 mg/kg to 10 mg/kg, 10 mg/kg to 15 mg/kg, 15 mg/kg to 20 mg/kg, 15 mg/kg to 25 mg/kg, 20 mg/kg to 30 mg/kg, or 25 mg/kg to 50 mg/kg. In some embodiments, the highest dose tolerated by a subject that is therapeutically effective is 1 mg/kg, 2 mg/kg, 3 mg/kg, 4 mg/kg, 5 mg/kg, 6 mg/kg, 7 mg/kg, 8 mg/kg, 9 mg/kg, 10 mg/kg, 11 mg/kg, 12 mg/kg, 13 mg/kg, 14 mg/kg, or 15 mg/kg. In certain embodiments, the highest dose tolerated by a subject that is therapeutically effective is 20 mg/kg, 25 mg/kg, 30 mg/kg, 35 mg/kg, 40 mg/kg, 45 mg/kg, or 50 mg/kg.

[0100] In certain embodiments, a dose of ASM described herein is administered every 3 days, every 4 days, every 5 days, every 6 days, every week, every 8 days, every 9 day, every 10 days, every 11 days, every 12 days, every 13 days, every 2 weeks, every 3 weeks, every 4 weeks, or every 5 weeks to a subject. In some embodiments, a dose of ASM described herein is administered every 3 to 5 days, every 3 to 7 days, every 5 to 7 days, every 5 to 10 days, every 5 to 14 days, every 7 to 14 days, every 2 to 4 weeks, or every 3 to 5 weeks to a subject. In certain embodiments, the frequency of administration of a dose of ASM changes as the dose is adjusted. For example, a dose of 0.3 mg/kg may be administered every week or two weeks and a dose of 1 mg/kg may be administered every two weeks or three weeks.

[0101] In some embodiments, a dose of ASM (e.g., a maintenance dose) is administered to a subject for a period for 12 weeks, 20 weeks, 25 weeks, 30 weeks, 35 weeks, 40 weeks, 45 weeks, 50 weeks, 52 weeks, 1 year, 1.5 years, 2 years, 2.5 years, 3 years, 3.5 years, 4 years or until the patient experiences a related adverse event, a total bilirubin value greater than the bilirubin value for a human without ASMD (e.g., a healthy human), a plasma ceramide concentration greater than the plasma ceramide concentration of a human without ASMD (e.g., a healthy human), or an acute phase response.

[0102] In certain embodiments, an initial low non-toxic dose of ASM is administered every 3 days, every 4 days, every 5 days, every 6 days, every week, every 8 days, every 9 day, every 10 days, every 11 days, every 12 days, every 13 days, every 2 weeks, every 3 weeks, every 4 weeks, or every 5 weeks to a subject. In some embodiments, a dose of ASM described herein is administered every 3 to 5 days, every 3 to 7 days, every 5 to 7 days, every 5 to 10 days, every 5 to 14 days, every 7 to 14 days, every 2 to 4 weeks, or every 3 to 5 weeks to a subject. In certain embodiments, the initial low non-toxic dose of ASM is administered for a period of 4 weeks, 6 weeks, 8 weeks, 12 weeks, 14 weeks or longer.

[0103] According to the invention, a successive increase in the dose of ASM is approximately 0.2 mg/kg, 0.3 mg/kg, 0.4 mg/kg, or 1 mg/kg, higher than the previous dose. In some cases, a

successive increase in the dose of ASM 0.1 to 0.5 mg/kg, 0.1 mg/kg to 1 mg/kg, 0.5 mg/kg to 1 mg/kg, 0.5 mg/kg to 2 mg/kg, 1 mg/kg to 2 mg/kg, 2 mg/kg to 4 mg/kg or 2 mg/kg to 5 mg/kg higher than the previous dose.

[0104] Doses of ASM described herein can be administered by any route that is useful in achieving a therapeutic effect. Specific routes of administration of doses of ASM include, but are not limited to, intravenous, intraventricular, intradermal, transdermal, subcutaneous, intramuscular, intranasal, inhalation, intrapulmonary, topical, transmucosal, intracranial, intrathecal, epidural and intra-synovial. In one embodiment, a dose of ASM is administered systemically (e.g., parenterally) to a subject in need thereof. In another embodiment, a dose of ASM is administered locally to a subject in need thereof.

[0105] The dose of ASM enzyme that is effective in treating the somatic (non-central nervous system) manifestations of ASMD is not able to effectively cross the blood-brain barrier. Thus, in specific embodiments, ASM is administered to a patient intraventricularly or intrathecally to the brain of a NPD patient. See, e.g., U.S. Patent Application Publication No. 2009/0130079 and 2009/0123451, for methods for intraventricular delivery of lysosomal storage enzymes to the brain. In certain embodiments, the ASM is administered to a patient intracerebraventricularly. See, e.g., Dodge et al., 2009, *Experimental Neurology* 215: 349-357, for methods for intracerebraventricular infusion of ASM. In some embodiments, the ASM is administered to a patient by indirect intraparenchymal injections. See, e.g., Yang et al., 2007, *Experimental Neurology* 207: 258-266. In some embodiments, a modified form of ASM that targets the enzyme to the brain, such as described in Section 5.2, *infra*, is administered to a patient to treat ASMD.

[0106] Only a small percentage of the ASM enzyme administered to a patient reaches the lung. Thus, in specific embodiments, ASM is administered to the lungs of a patient. In certain embodiments, ASM is administered by intranasal or inhalation to a patient. See, e.g., Ziegler et al., 2009, *Molecular Genetics and Metabolism* 97: 35-42, for information regarding the intranasal administration of ASM. In some embodiments, a modified form of ASM that targets the enzyme to the lung, such as described in Section 5.2, *infra*, is administered to a patient to treat ASMD. In certain embodiments, the ASM is administered to a patient using a nebulizer. Delivery of ASM to the lungs may occur by intrapulmonary injection through a bronchoscope, a metered-dose inhaler, or a nebulizer.

[0107] In certain embodiments, the ASM enzyme is administered systemically to a patient as well as locally administered to specific organs, such the brain and lung. In some embodiments, the locally administration of the ASM enzyme supplements the systemic administration of the enzyme. In specific embodiments, the ASM enzyme is administered locally to, e.g., the brain or lungs, after the accumulated sphingomyelin in the patient has been debulked by systemic administration (e.g., intravenous administration).

[0108] In certain embodiments, a patient is genotyped prior to the administration of ASM. In some embodiments, the glycosylation pattern of the ASM expressed by a patient is determined

prior to administration of ASM. The administration of ASM that is similar/compatible with that endogenously expressed by a patient may reduce the potential for immunogenicity.

[0109] In certain embodiments, the activity of endogenously expressed ASM is determined prior to the administration of ASM. The activity of endogenously expressed ASM can be measured in DBS and in cultured fibroblasts using techniques known to one of skill in the art.

[0110] In a specific embodiment an ASM for use in the methods for treating ASMD provided herein reduce spleen volume as assessed by techniques known in the art, *e.g.*, MRI. In another specific embodiment an ASM for use in the methods for treating ASMD provided herein reduce liver sphingomyelin levels as assessed by techniques known in the art, *e.g.*, biochemical analysis and/or histomorphometric analysis of liver samples. In another specific embodiment an ASM for use in the methods for treating ASMD provided herein increase exercise capacity as assessed by techniques known in the art, *e.g.*, maximum workload by cycle ergometry, including percent predicted maximum workload, peak oxygen consumption, and carbon dioxide production. In another specific embodiment an ASM for use in the methods for treating ASMD provided herein increase in pulmonary function as assessed by techniques known in the art, *e.g.*, DLco, FVC, FEV, and/or TLC. In another specific embodiment an ASM for use in the methods for treating ASMD provided herein decrease in bronchial alveolar lavage (BAL) sphingomyelin. In another specific embodiment, the methods for treating ASMD provided herein decrease in liver volume as assessed by techniques known in the art, *e.g.*, MRI. In another specific embodiment an ASM for use in the methods for treating ASMD provided herein improve lung appearance as assessed by techniques known in the art, *e.g.*, high resolution CT scan or chest X-ray. In another specific embodiment an ASM for use in the methods for treating ASMD provided herein improve lung clearance. In another specific embodiment an ASM for use in the methods for treating ASMD provided herein decrease in sphingomyelin concentration in the liver, skin, plasma and DBS. In another specific embodiment, the methods for treating ASMD provided herein reduce serum chitotriosidase levels. In another specific embodiment an ASM for use in the methods for treating ASMD provided herein reduce serum CCL18 levels. In another specific embodiment an ASM for use in the methods for treating ASMD provided herein improve a patient's lipid profile (*e.g.*, decrease cholesterol). In another specific embodiment an ASM for use in the methods for treating ASMD provided herein reduce or ameliorate the severity of ASMD and/or a symptom associated therewith. In another specific embodiment an ASM for use in the methods for treating ASMD provided herein reduce the duration of a symptom associated with ASMD. In another specific embodiment an ASM for use in the methods for treating ASMD provided herein prevent the recurrence of a symptom associated with ASMD. In another specific embodiment an ASM for use in the methods for treating ASMD provided herein a reduces hospitalization of a subject. In another specific embodiment an ASM for use in the methods for treating ASMD provided herein reduces hospitalization length. In another specific embodiment an ASM for use in the methods for treating ASMD provided herein increases the survival of a subject. In another specific embodiment an ASM for use in the methods for treating ASMD provided herein reduces the mortality of subject. In another specific embodiment an ASM for use in the methods for treating ASMD provided herein decreases hospitalization rate of a subject. In another specific embodiment an ASM for use in the methods for treating ASMD provided herein reduces the number of symptoms associated with ASMD. In another specific

embodiment an ASM for use in the methods for treating ASMD provided herein increases symptom-free survival of ASMD patients. In another specific embodiment an ASM for use in the methods for treating ASMD provided herein improve in neurological function (e.g., psychomotor function, social responsiveness, etc.) of a subject.

[0111] In another specific embodiment an ASM for use in the methods for treating ASMD provided herein improve a patient's quality of life. In certain specific embodiments an ASM for use in the method for treating ASMD provided herein improve a patient's quality of life as assessed by, e.g., the Brief Fatigue Inventory (BFI; Mendoza et al., 1999, Cancer 85(5): 1186-1196), the Brief Pain Inventory-Short Form (BPI-SF; Cleeland et al., 1994, Ann Acad Med Singapore 23(2): 129-138), the ASM-Health Assessment Questionnaire, which is a composite of the BFI, BPI-SF, and Short Form-36 Health Survey, the Chronic Respiratory Disease Questionnaire Self-Administered Standardized (CRQ-SAS; Schunemann et al., 2005, Eur. Respir. J. 25: 31-40) to assess dyspnea and fatigue, and the Activity Measure for Post-Acute Care (AM-PAC), a computer-adaptive test that assesses functional motilities (e.g., mobility, self-care, and applied cognition).

Acid spHingomyelinase enzyme

[0112] ASM refers to any form the acid sphingomyelinase enzyme that retains the ability to hydrolyze sphingomyelin to ceramide and phosphorylcholine as assessed by techniques known to one of skill in the art, such as those described in U.S. Patent Nos. 4,039,388, 4,082,781, 5,686,240, and 7,563,591, and International Publication Nos. WO 2007/078806 and WO 2006/058385. In a specific embodiment, an acid sphingomyelinase enzyme has the ability to hydrolyze sphingomyelin to ceramide and phosphorylcholine in the fluorescence-based, high-performance liquid chromatographic assay described in He et al., 2003, Analytical Biochemistry 314: 116-120. In a specific embodiment, an acid sphingomyelinase has at least 30%, 35%, 40%, 45%, 50%, 75%, 80%, 85%, 80%, 90%, 95% or 98%, or 30% to 50%, 40% to 50%, 50% to 75%, 50% to 90%, 75% to 80%, 75% to 90%, 75% to 95%, or 85% to 95% of the activity of ASM-1 (SEQ ID NO: 1, *infra*) as measured by, e.g., the assay described in He et al., 2003, Analytical Biochemistry 314: 116-120.

[0113] In a specific embodiment, the ASM is a human ASM. There are various isoforms of human ASM resulting from alternative splicing. One of the human ASM isoforms, human ASM isoform 1 (sometimes referred to as ASM-1), has the amino acid sequence found at UniProtKB/Swiss-Prot Accession No. P17405-1. Another human ASM isoform, human isoform 2 (sometimes referred to as ASM-2), has the amino acid sequence found at UniProtKB/Swiss-Prot. Accession No. P17405-2. A third human ASM isoform, human isoform 3 (sometimes referred to as ASM-3), has the amino acid sequence found at UniProtKB/Swiss-Prot. Accession No. P17405-3. The amino acid sequence of ASM-1, which is the most abundant isoform, is provided below:

```
10      20      30      40      50      60
MPRYGASLRQ SCPRSGREQG QDGTAGAPGL LWMGLVLALA LALALALSDS RVLWAPAEAH
```

```

70      80      90      100     110     120
PLSPQGHPAR LHRIVPRLRD VFGWGNLTCP ICKGLFTAIN LGLKKEPNVA RVGSVAIKLC

130     140     150     160     170     180
NLLKIAPPAV CQSIVHLFED DMVEVWRRSV LSPSEACGLL LGSTCGHWDI FSSWNISLPT

190     200     210     220     230     240
VPKPPPKPPS PPAPGAPVSR ILFLTDLHWD HDYLEGTDPD CADPLCCRRG SGLPPASRPG

250     260     270     280     290     300
AGYWGEYSKC DLPLRTLLESL LSGLGPAAGPF DMVYWTGDIP AHDVWHQTRQ DQLRALTTVT

310     320     330     340     350     360
ALVRKFLGPV PVYPAVGNHE STPVNSFPPP FIEGNHSSRW LYEAMAKAWE PWLPAEALRT

370     380     390     400     410     420
LRIGGFYALS PYPGLRLISL NMNFCSSRENF WLLINSTDPA GQLQWLVGEL QAAEDRGDKV

430     440     450     460     470     480
HIIGHIPPGH CLKSWSWNYR RIVARYENTL AAQFFGHTHV DEFEVYDEE TLSRPLAVAF

490     500     510     520     530     540
LAPSATTYIG LNPGYRVYQI DGNYSGSSHV VLDHETYILN LTQANIPGAI PHWQLLYRAR

550     560     570     580     590     600
ETYGLPNTLP TAWHNLVYRM RGDMLFQTF WFLYHKGHPP SEPCGTPCRL ATLCAQLSAR

610     620
ADSPALCRHL MPDGSLPEAQ SLWPRPLFC

```

(**SEQ ID NO:1**). ASM-2 differs from ASM-1 in that amino acid residues 363 to 374 of ASM-1 (*i.e.*, IGGFYALSPYPG (**SEQ ID NO:2**)) are replaced with amino acids YLSSVETQEGKR (**SEQ ID NO:3**) and amino acid residues 375 to 418 of ASM-1 are missing from ASM-2. ASM-3 differs from ASM-1 in that amino acid residues 363 to 418 of ASM-1 are missing from ASM-3. To the extent that ASM-2 and ASM-3 have enzymatic activity as measured by, *e.g.*, the assay described in He et al., 2003, Analytical Biochemistry 314: 116-120, they are included as an ASM that could be administered to a subject. In a specific embodiment, to the extent that ASM-2 and ASM-3 have at least 30%, 35%, 40%, 45%, 50%, 75%, 80%, 85%, 80%, 90%, 95% or 98%, or 30% to 50%, 40% to 50%, 50% to 75%, 50% to 90%, 75% to 80%, 75% to 90%, 75% to 95%, or 85% to 95% of the activity of ASM-1 as measured by, *e.g.*, the assay described in He et al., 2003, Analytical Biochemistry 314: 116-120, they are included as an ASM that could be administered to a subject.

[0114] In a specific embodiment, the human ASM has the amino acid sequence of human acid sphingomyelinase disclosed in SEQ ID NO:1, *supra*, the amino acid sequence of a human acid sphingomyelinase disclosed in U.S. Patent No. 6,541,218 (*e.g.*, SEQ ID NO:2 in U.S. Patent No.

6,541,218), or the amino acid sequence disclosed in Figure 3 of Schuchman et al., 1991, J. Biol. Chem. 266: 8531-8539.

[0115] In specific embodiments, the human ASM is the processed mature form. In other embodiments, the human ASM is the immature, unprocessed form. With respect to ASM-1, the immature form is 629 amino acids in length and contains the signal peptide found at amino acid residues 1 to 46. The mature form of ASM-1 lacks that signal peptide and is from amino acid residue 47 to amino acid residue 629. Human ASM-1 contains a saposin B-type domain from amino acid residues 85 to 169. With respect to ASM-1, the following amino acid residues are glycosylated (in particular, N-linked glycosylated): 86, 175, 335, 395, and 520.

[0116] In addition to the isoforms of human ASM, there are various naturally occurring variants of human ASM. For example, naturally occurring variants of the human ASM gene with different numbers of hexanucleotide repeat units occurring within the region of the gene encoding the putative signal peptide of ASM have been identified. See, e.g., Wan and Schuchman, 1995, *Biochimica et Biophysica Acta* 1270: 207-210 which describes the identification of five alleles corresponding to nine, seven, six, five and four hexanucleotide repeats. Further, naturally occurring variants of human ASM with single amino acid variations have been identified. See, e.g., Schuchman et al., 1991, *J. of Biol. Chem* 266: 8531-8539 and Schuchman et al., 1991, *Nucleic Acids Research* 19(11): 3160, for information regarding single polymorphisms. To the extent that any of the naturally occurring variants of human ASM have enzymatic activity as measured by, e.g., the assay described in He et al., 2003, *Analytical Biochemistry* 314: 116-120, they are included as an ASM that could be administered to a subject. In a specific embodiment, to the extent that any of the naturally occurring variants of human ASM have at least 30%, 35%, 40%, 45%, 50%, 75%, 80%, 85%, 80%, 90%, 95% or 98%, or 30% to 50%, 40% to 50%, 50% to 75%, 50% to 90%, 75% to 80%, 75% to 90%, 75% to 95%, or 85% to 95% of the activity of ASM-1 as measured by, e.g., the assay described in He et al., 2003, *Analytical Biochemistry* 314: 116-120, they are included as an ASM that could be administered to a subject.

[0117] Many single nucleotide polymorphisms (SNPs) for the gene encoding human ASM have been identified (see, e.g., the ncbi website: ncbi.nlm.nih.gov/projects/SNP/ for examples of SNPs). To the extent that any of the SNPs in the gene encode of an ASM that has enzymatic activity as measured by, e.g., the assay described in He et al., 2003, *Analytical Biochemistry* 314: 116-120, they are included as an ASM that could be administered to a subject. In a specific embodiment, to the extent that any of the SNPs in the gene encode of an ASM that has at least 30%, 35%, 40%, 45%, 50%, 75%, 80%, 85%, 80%, 90%, 95% or 98%, or 30% to 50%, 40% to 50%, 50% to 75%, 50% to 90%, 75% to 80%, 75% to 90%, 75% to 95%, or 85% to 95% of the activity of ASM-1 as measured by, e.g., the assay described in He et al., 2003, *Analytical Biochemistry* 314: 116-120, they are included as an ASM that could be administered to a subject.

In certain embodiments, the ASM is a modified form of human ASM. In a specific embodiment, the modified form of human ASM is one disclosed in U.S. Patent No. 7,527,956. In another embodiment, the modified form of human ASM is one disclosed in International Publication No. WO 2008/136451. In some specific embodiments, the ASM is a modified form of human ASM that has one, two or more of the following properties: (i) increased targeting to sites of pathology

(e.g., the lung and/or brain) relative to unmodified human ASM, (ii) increased stability relative to unmodified human ASM, and (iii) increased activity relative to unmodified human ASM. Techniques known in the art can be used to measure the stability, activity and targeting of ASM. In a specific embodiment, the techniques described in Gamacho et al., 2008, J. Pharmacol. Exp. Ther. 325: 400-408 for assessing targeting of ASM are used. In another specific embodiment, the techniques described in He et al., 1999, Biochimica et Biophysica Acta 1432: 251-264 or Dhimi et al., 2001, Lab. Invest. 81: 987-999 for assessing stability of the ASM are used. In another specific embodiment, the techniques described in He et al., 2003, Analytical Biochemistry 314: 116-120 for assessing ASM activity are used.

[0118] In one embodiment, the ASM is a modified form of human ASM that has increased enzymatic activity relative to unmodified human ASM, such as ASM-1. See, e.g., Qiu et al., 2003, J. Biol. Chem. 278(35): 32744-32752 and U.S. Patent No. 7,527,956 for a mutant forms of recombinant human ASM with enzymatic activity with higher activity than wild-type recombinant human ASM (such as, e.g., ASM-1). In some embodiments, the ASM has increased enzymatic activity relative to unmodified human ASM (such as, e.g., ASM-1) due to the addition of zinc cations. See, e.g., Schissel et al., 1998, J. Biol. Chem 273: 18250-18259, for a discussion regarding the role of zinc in ASM activity. In another embodiment, the ASM is a modified form of human ASM that has increased affinity for a natural receptor of human ASM (e.g., mannose 6-phosphate or high mannose) relative to unmodified human ASM (such as, e.g., ASM-1). In a specific embodiment, the ASM is conjugated to an oligosaccharide, such as described in U.S. Patent No. 7,001,994 and International Patent Application Publication No. WO 2010/075010 and United States Patent Application Publication No. 2010/0173385, to increase the targeting the enzyme for its natural receptor. In another embodiment, the ASM is a modified form of human ASM that binds to an alternative receptor (e.g., intercellular adhesion molecule (ICAM) -1 which may increase targeting to organs such as the lung) than the natural receptor for ASM. In embodiment, the ASM is a modified form of human ASM that has increased stability relative to unmodified human ASM (such as, e.g., ASM-1).

[0119] In some embodiments, the ASM is conjugated or fused, directly or indirectly, to a targeting moiety, such as insulin-like growth factor (IGF)-I, IGF-II, leptin, granulocyte colony stimulating factor (G-CSF), or a humanized antibody that binds to human insulin receptor (HIR). See, e.g., U.S. Patent Application Publication No. 2009/0029467 and U.S. Patent No. 7,560,424 for a discussion of the use of IGF-I as a targeting moiety for lysosomal storage enzymes, and U.S. Patent No. 7,396,811 for a discussion of the use of IGF-II as a targeting moiety for lysosomal storage enzymes. The targeting moieties IGF-I and IGF-II can facilitate targeting the ASM enzyme to the lysosome. For a discussion of the use of hormones, such as G-CSF and leptin as targeting moieties see, e.g., International Patent Application Publication No. WO 2007/091250 and U.S. Patent Application Publication No. 2010/0183577. See, e.g., U.S. Patent Application Publication No. 2004/0101904, for a discussion of a humanized monoclonal antibody that binds human insulin receptor (HIR) linked to a pharmaceutical agent, such as an enzyme. The targeting moieties G-CSF, leptin and an antibody that binds to HIR can facilitate targeting of the ASM enzyme to the brain.

[0120] In certain embodiments, the ASM is a modified form of ASM (e.g., a modified form of human ASM) with a decrease in activity relative to unmodified ASM (such as, an unmodified human ASM, e.g., ASM-1). In some embodiments, the ASM is a modified form of ASM (e.g., a modified form of human ASM) with an increase in targeting to sites of pathology and a decrease in enzymatic activity relative to unmodified ASM (such as an unmodified human ASM, e.g., ASM-1).

[0121] In certain embodiments, the ASM is a highly phosphorylated form of ASM. See, e.g., U.S. Patent Application Publication No. 2002/0150981 for a discussion of techniques for producing highly phosphorylated forms of lysosomal enzymes.

[0122] The ASM enzyme can be produced by any method known in the art, including but not limited to recombinant DNA methods, cDNA cloning (see, e.g., Schuchman et al., 1991, J. Biol. Chem 266: 8531-8539 and U.S. Patent No. 5,773,278 for cDNA clones of human ASM), genomic cloning, gene activation (see, e.g., U.S. Patent No. 5,641,670 for gene activation techniques), or selected cell lines (e.g., mammalian, yeast, prokaryotic, insect cells (e.g., Sf9, Sf21, *Trichoplusia ni*, *Spodoptera frugiperda* and *Bombyx mori*), and plant cells) that produce high levels of the ASM enzyme. ASM as well as methods for producing ASM are described, e.g., in U.S. Patent Nos. 5,773,278; 6,541,218; 5,686,240; and 7,527,956.

[0123] In a specific embodiment, the ASM is a recombinantly produced ASM (e.g., a recombinantly produced human ASM). Cell expression systems which possess the cellular machinery and elements for the proper processing, i.e., signal cleavage, glycosylation, phosphorylation and protein sorting are preferred. For example, mammalian cell expression systems are preferred for the expression of biologically active enzymes that are properly folded and processed; when administered in humans such expression products should exhibit proper tissue targeting and no adverse immunological reaction.

[0124] In certain embodiments, the ASM (e.g., human ASM) is produced by overexpression of ASM cDNA in mammalian cells. In a specific embodiment, the human ASM is produced by overexpression of human ASM cDNA in Chinese hamster ovary (CHO) cells. See, e.g., He et al., 1999, *Biochimica et Biophysica Acta* 1432: 251-264 for methods for overexpression of human ASM cDNA in CHO cells, and US 6,541,218. In certain embodiments, the human ASM is produced by overexpression of human ASM cDNA in CHO cells that co-express alpha-2,6-sialyltransferase. See, e.g., U.S. Patent No. 5,047,335 which describes CHO cells engineered to express alpha 2,6-sialyltransferase.

[0125] In another specific embodiment, the mammalian cells are human cells. Examples of human cells that may be used to recombinantly express ASM (e.g., human ASM) include, but are not limited to Crucell Per.C6 cells, HT 1080 cells, HeLa cells, HEK 293 cells, 293T cells, WI38 cells, HuT292 cells, LF 1043 (HEL) cells, MRC-5 cells, TMK-1 cells, BT483 cells, Hs578T cells, HTB2 cells, HTB3 cells, HTB4 cells, BT 20 cells, T47D cells, CRL7030 cells, HsS78Bst cells, 721 cells, A2780 cells, A172 cells., A253 cells, COR-L23/R23 cells, COV-434 cells, DU145 cells, DuCaP cells, EM2 cells, Saos-2 cells, U373 cells, WM39 cells, L132 cells, A-5489 cells, G-293 cells, G-401 cells, CAKI-1 cells, RD cells, and YAR cells. Other exemplary human cells that

may be used to express ASM include those human cell lines listed in the Immuno Polymorphism Database of the European Molecular Biology Laboratory, and the database of the U.S. National Institutes of Health, as well as those commercially available form, for example, the American Type Culture Collection, Manassas, Virginia, and Lifeline Cell Technology, Walkersville, Maryland. When using human cell lines for production, rhASM can be produced using cDNAs, gDNAs for hASM or by gene activation techniques such as those described in U.S. Patent No. 5,641,670.

[0126] Examples of other mammalian cells that may be used to produce ASM (e.g., human ASM) include, but are not limited to, Vero cells, VERY cells, BHK cells, COS cells, MDCK cells, or 3T3 cells. In certain embodiments, myeloma cells are used to produce ASM (e.g., human ASM). Non-limiting examples of myeloma cells include NS0 cells, 45.6 TG1.7 cells, AF-2 clone 9B5 cells, AF-2 clone 9B5 cells, J558L cells, MOPC 315 cells, MPC-11 cells, NCI-H929 cells, NP cells, NS0/1 cells, P3 NS1 Ag4 cells, P3/NS1/1-Ag4-1 cells, P3U1 cells, P3X63Ag8 cells, P3X63Ag8.653 cells, P3X63Ag8U.1 cells, RPMI 8226 cells, Sp20-Ag14 cells, U266B1 cells, X63AG8.653 cells, Y3.Ag.1.2.3 cells, and YO cells.

[0127] In some embodiments, a plant cell culture system is used for expression of the ASM. See, e.g., U.S. Patent Nos. 5,929,304; 7,504,560; 6,770,799; 6,551,820; 6,136,320; 6,034,298; 5,914,935; 5,612,487; and 5,484,719, U.S. patent application publication Nos. 2009/0208477, 2009/0082548, 2009/0053762, 2008/0038232, 2007/0275014 and 2006/0204487, and Shoji et al., 2008, Vaccine, 26(23):2930-2934, and D'Aoust et al., 2008, J. Plant Biotechnology, 6(9):930-940 for plant cells and methods for the production of proteins utilizing plant cell culture systems. In particular, U.S. patent application Nos. 2009/0208477, 2008/0038232 and 2006/0204487 describe the expression and production of enzymatically active high mannose lysosomal enzymes using transgenic plant root, particularly carrot cells. In a specific embodiment, carrot cells are engineered to express ASM. In certain embodiments, algae (e.g., *Chlamydomonas reinhardtii*) may be engineered to express ASM (see, e.g., Rasala et al., 2010, Plant Biotechnology Journal (Published online March 7, 2010).

[0128] Tissue and cellular uptake of ASM is mediated by both the high mannose residues (e.g., in macrophages) and by mannose-6-phosphate (e.g., in liver). Thus, production of ASM with altered glycan content and/or phosphorylation may be desired to enhance drug distribution. For example, ASM can be produced by cells having a mutation, e.g., a knockout for, at least one Golgi processing mannosidase. In one embodiment, the mutation reduces the expression of the gene, reduces protein or activity levels, or alters the distribution or other post translational modifications of the mannosidase, e.g., the processing of the carbohydrate chains. In a specific embodiment, the mutation reduces the level of the Golgi processing mannosidase activity. The mutation can be in a class 1 processing mannosidase; a class 2 processing mannosidase; a class 1 processing mannosidase and a class 2 processing mannosidase. Class 1 processing mannosidase includes: Golgi mannosidase IA; Golgi mannosidase IB; Golgi mannosidase IC. Class 2 processing mannosidase includes: Golgi mannosidase II. See, e.g., International Patent Application Publication No. WO 02/15927 and U.S. Patent No. 7,138,262 for methods of producing a high mannose protein.

[0129] In certain embodiments, cells expressing ASM are cultured in the presence of mannosidase inhibitor, such as an antibody, kifunensine, swainsonine, mannostatin, 6-deoxy-1, 4- dideoxy-1,4-imino-D-mannitol (6-deoxy-DIM), or 6-deoxy-6-fluoro-1, 4-dideoxy-1, 4- imino-D-mannitol (6-deoxy-6-fluoro-DIM). The culture of ASM in the presence of such inhibitors may result in the production of a high mannose ASM. In some embodiments, the cells expressing ASM include a nucleic acid sequence, such as an antisense molecule or ribozyme, which can bind to or inactivate a cellular mannosidase nucleic acid sequence, *e.g.*, mRNA, and inhibit expression of the protein. *See, e.g.*, International Patent Application Publication No. WO 02/15927 and U.S. Patent No. 7,138,262 for methods of producing a high mannose protein.

[0130] In certain embodiments, the carbohydrate chains of the ASM enzyme recombinantly expressed are remodeled by sequential treatment with various enzymes, such as neuraminidase, galactosidase and beta.-N acetylglucosaminidase. *See, e.g.*, U.S. Patent No. 5,549,892 for a methods for remodeling carbohydrate chains of a lysosomal enzyme.

[0131] Uptake of ASM, mediated by mannose-6-phosphate (M6P) can be enhanced by modification of ASM to produce highly phosphorylated mannose residues and M6P. For example, ASM can be modified by recombinant technology to introduce additional mannose-6-phosphate to the ASM for enhancing cellular uptake. *See, e.g.*, Matsuoka et al., 2010 *Mole. Ther.*18:1519-1526. In other embodiments, ASM can be coupled to highly phosphorylated oligosaccharide derivatives containing mannose 6-phosphate (M6P). *See, e.g.*, U.S. Patent No. 7,001,994, U.S Patent Application Publication US2010/0173385 and International Publication No. WO2010/075010. In another approach, a yeast culture system can be used for the expression of recombinant ASM that contains additional highly phosphorylated mannose-6-phosphate residues. *See, e.g.*, Akeboshi et al., 2009 *Glycobiology* 19(9):1002-1009.

[0132] Once ASM has been produced, it may be isolated or purified by any method known in the art for isolation or purification of a protein, for example, by chromatography (*e.g.*, ion exchange, high performance liquid chromatography, affinity, particularly by affinity for ASM, by Protein A, and sizing column chromatography), centrifugation, differential solubility, or by any other standard technique for the isolation or purification of proteins. Where the ASM enzyme is secreted by the cultured cells, ASM may be readily recovered from the culture medium. *See, e.g.*, He et al., 1999, *Biochimia et Biophysica Acta* 1432: 251-264 for methods for purifying ASM.

[0133] The ASM enzyme can be formulated for any route of administration (*e.g.*, infusion, subcutaneous, intramuscular, intrathecal, intraventricular, intranasal, inhalation or intradermal). The ASM enzyme can be supplied in a lyophilized form that is reconstituted before use with, *e.g.*, sterile saline (*e.g.*, 0.9 % sodium chloride) or sterile water. Alternatively, the ASM enzyme can be supplied in an aqueous form. In certain embodiments, ASM is administered to a subject in a formulation comprising zinc. In some embodiments, the ASM enzyme is administered to the patient by infusion using, *e.g.*, a syringe pump or an infusion bag with a pump.

[0134] In certain embodiments, ASM is administered to a subject in a carrier, such as liposomes or a polycationic carrier. *See, e.g.*, U.S. Patent No. 5,716,614 for a carriers that can be used to

administered ASM. In some embodiments, the ASM administered to a subject in ICAM-1-target nanocarriers. See, e.g., Muro et al., 2006, Mol. Ther. 13(1): 135-141 for ASM delivery using ICAM-1-targeted nanocarriers.

5.2. PATIENT POPULATIONS

[0135] In specific embodiments, a subject treated for ASMD in accordance with the invention provided herein is a human who has or is diagnosed as having one or more mutations in the gene encoding acid sphingomyelinase. In particular embodiments, a subject treated for ASMD in accordance with the invention provided herein is a human who has or is diagnosed as having Niemann-Pick disease (NPD). In one embodiment, a subject treated for ASMD in accordance with the invention provided herein is a human who has or is diagnosed as having NPD Type A. In another specific embodiment, a subject treated for ASMD in accordance with the invention provided herein is a human who has or is diagnosed as having NPD Type B.

[0136] In certain embodiments, a subject treated for ASMD in accordance with the invention provided herein has one or more mutations in the SMPD1 gene. In some embodiments, the mutation is a missense mutation. In other embodiments, the mutation is a deletion that results in the deletion of one, two or more amino acid residues. In specific embodiments, a subject treated for ASMD in accordance with the invention provided herein has one or more of the mutations

Table 1

Amino Acid Position of ASM-1	Mutation
49	D → V in NPDB
92	C → W in NPDB
103	L → P in NPDA and NPDB
130	V → A in NPDB
137	L → P in NPDB
157	C → R in NPDB
166	G → R in NPDB
176	I → N in NPDB
184	P → L in NPDA/NPDB
196	A → P in NPDB
200	R → C in NPDB
225	L → M in NPDB
225	L → P in NPDB
228	R → C in NPDB
228	R → H in NPDA/NPDB
232	G → D in NPDB
241	A → V in NPDA/NPDB

Amino Acid Position of ASM-1	Mutation
242	G → R in NPDB
244	W → C in NPDB
245	G → S in NPDA and NPDB
246	E → K in NPDA
246	E → Q in NPDA
248	S → R in NPDA and NPDB
251	D → E in NPDA/NPDB
278	D → A in NPDA/NPDB
281	A → T in NPDB
289	R → H in NPDB
292	Q → K in NPDA/NPDB
294	R → Q in NPDA
302	L → P in NPDA
313	Y → H in NPDA
319	H → Y in NPDA
323	P → A in NPDB.
330	P → R in NPDB
341	L → P in NPDA/NPDB
357	A → D in NPDB
367	Y → C in NPDA
371	P → S in NPDB
376	R → H in NPDB
376	R → L in NPDB
379	S → P in NPDB
382	M → I in NPDA
383	N → S in NPDB
389	N → T in NPDA
390	Missing in NPDA.
391	W → G in NPDB
413	A → V in NPDB
421	H → R in NPDA
421	H → Y in NPDB
431	C → R in NPDB
432	L → P in NPDB
435	W → C in NPDB

Amino Acid Position of ASM-1	Mutation
436	S → R in NPDB
446	Y → C in NPDA
450	L → P in NPDA
452	A → V in NPDB
456	G → D in NPDB
463	F → S in NPDA
467	Y → S in NPDA
474	R → W in NPDB
475	P → L in NPDA and NPDB
480	F → L in NPDB
482	A → E in NPDA
485	A → V in NPDB
486	T → A in NPDB
488	Y → N in NPDB
494	G → S in NPDB
496	R → C in NPDB
496	R → H in NPDA
496	R → L in NPDA
514	H → Q in NPDB
515	E → V in NPDB
517	Y → C in NPDA
533	W → R in NPDB
537	Y → H in NPDA
549	L → P in NPDB
563	D → Y in NPDB
576	K → N in NPDB
577	G → S in NPDA
592	Missing in NPDA.
600	R → H in NPDB
600	R → P in NPDB
608	Missing in NPDB

See, e.g., Simonaro et al., 2002, Am. J. Hum. Genet. 71: 1413-1419 for mutations in the acid sphingomyelinase gene (designated SMPD1).

[0137] In certain embodiments, a subject treated for ASMD in accordance with the invention provided herein endogenously expresses ASM with 2 to 5%, 5 to 10%, 5 to 15%, 5 to 20%, 5%

to 30%, or 20% to 30% of the activity of normal, human ASM, *e.g.*, ASM-1. In some embodiments, a subject treated for ASMD in accordance with the invention provided herein endogenously expresses ASM with less than 30%, 25%, 20%, 15%, 10%, 5%, 4%, 3%, 2% or 1% of the activity of normal, human ASM, *e.g.*, ASM-1. See, *e.g.*, U.S. Patent Nos. 4,039,388, 4,082,781, 5,686,240, and 7,563,591, and International Publication Nos. WO 2007/078806 and WO 2006/058385 for techniques that can be used to measure the activity of ASM. In a specific embodiment, the fluorescence-based, high-performance liquid chromatographic assay described in He et al., 2003, *Analytical Biochemistry* 314: 116-120 is used to measure the activity of ASM.

[0138] In certain embodiments, a subject treated for ASMD in accordance with the invention provided herein displays one or more symptoms of NPD. Symptoms of NPD include, but are not limited to, distended abdomens, hepatomegaly, splenomegaly, hepatosplenomegaly, neutropenia, pulmonary disease, lymphadenopathy, the presence of histochemically characteristic NPD foam cells, anemia (*e.g.*, microcytic anemia), thrombocytopenia, recurrent vomiting, chronic constipation, growth failure (*e.g.*, decreased linear growth and body weight), delayed puberty, recurrent bruising, recurrent bleeding, atherogenic lipid profile (high cholesterol, triglycerides, LDL, and low HDL), pain (headache, back, extremities, abdomen), fatigue, early satiety, low endurance, osteopenia, neurological manifestations, and respiratory difficulties (*e.g.*, interstitial lung disease, shortness of breath). Neurological manifestation of NPD include cherry red spot, hypotonia, muscle weakness, psychomotor retardation, spasticity, social unresponsiveness, irritability, and seizures.

[0139] In certain embodiments, a subject treated for ASMD in accordance with the invention provided herein is a human subject that displays two or more clinical features consistent with non-neuropathic NPD. In specific embodiments, a subject treated for ASM in accordance with the invention provided herein is a human subject that displays two or more clinical features consistent with non-neuropathic NPD: thrombocytopenia, anemia, neutropenia, hepatomegaly, splenomegaly, and pulmonary disease. In other embodiments, a subject treated for ASMD in accordance with the invention provided herein is a human subject that displays two or more clinical features consistent with neuropathic NPD.

[0140] In certain embodiments, a subject treated for ASMD in accordance with the invention provided herein is a human with a spleen volume two, three, four, five, six, seven, eight, nine, ten, eleven or twelve times greater than the spleen volume of a healthy human as assessed by techniques known in the art, such as, *e.g.*, magnetic resonance imaging (MRI). In specific embodiments, a subject treated for ASMD in accordance with the invention provided herein is a human with a spleen volume greater than eight times the spleen volume of a healthy human as assessed by techniques known in the art, such as, *e.g.*, MRI. In some embodiments, a subject treated for ASMD in accordance with the invention provided herein is a human with a spleen volume eight to twelve, nine to twelve, ten to twelve, or twelve to fourteen times greater than the spleen volume of a healthy human as assessed by techniques known in the art, such as, *e.g.*, MRI. In specific embodiments, a subject treated for ASMD in accordance with the invention provided herein is a human with a spleen volume ≥ 8 multiples of normal (MN) (*i.e.*, 1.6% of body weight) as assessed by techniques known in the art, such as, *e.g.*, MRI.

[0141] In certain embodiments, a subject treated for ASMD in accordance with the invention provided herein is a human with a diffusing capacity (DLco) between 20% to 80%, 25% to 80%, 30% to 80%, 40% to 80%, 50% to 80%, or 60% to 80% of the predicted DLco of a healthy human. In some embodiments, a subject treated for ASMD in accordance with the invention provided herein is a human with a DLco of between 20% to 90%, 25% to 90%, 30% to 90%, 40% to 90%, 50% to 90%, 60% to 90%, or 70% to 90% of the predicted DLco of a healthy human. DLco measures the rate of diffusion of a diffusion-limited gas (e.g., carbon monoxide) per minute across the alveolocapillary membrane. DLco can be calculated by comparing the amount of carbon monoxide exhaled following a known amount of inhaled carbon monoxide. Techniques known in the art can be used to assess DLco.

[0142] In certain embodiments, a subject treated for ASMD in accordance with the invention provided herein is a human infant. In some embodiments, a subject treated for ASMD in accordance with the invention provided herein is a human that is 2 to 3 months old, 2 to 6 months old, 3 to 6 months old, 4 to 6 months old, 5 to 8 months old, or 6 to 9 months old. In other embodiments, a subject treated for ASMD in accordance with the invention provided herein is a human child. In some embodiments, a subject treated for ASMD in accordance with the invention provided herein is a human that is 1 to 3 years old, 2 to 3 years old, 3 to 5 years old, 4 to 5 years old, 5 to 7 years old, or 6 to 9 years old.

[0143] In certain embodiments, a subject treated for ASMD in accordance with the invention provided herein is a human adult. In other embodiments, a subject treated for ASMD in accordance with the invention described herein is an elderly human. In some embodiments, a subject treated for ASMD in accordance with the invention provided herein is a human that is 10 to 18 years old, 10 to 20 years old, 12 to 20 years old, 15 to 20 years old, 20 to 25 years old, 21 to 25 years old, 21 to 30 years old, 25 to 30 years old, 30 to 35 years old, 35 to 40 years old, 40 to 45 years old, 45 to 50 years old, 50 to 55 years old, 55 to 60 years old, 60 to 65 years old, 65 to 70 years old, 70 to 75 years old, 75 to 80 years old, 80 to 85 years old, 85 to 90 years old, 90 to 95 years old or 95 to 100 years old.

[0144] In specific embodiments, a subject treated for ASMD in accordance with the invention provided herein is a human female. In other embodiments, a subject treated for ASMD in accordance with the invention provided herein is a human male. In certain embodiments, a subject treated for ASMD in accordance with the invention provided herein is a female human that is not pregnant or is not breastfeeding. In other embodiments, a subject treated for ASMD in accordance with the invention provided herein is a female human that is pregnant or will become pregnant, or is breastfeeding.

[0145] In certain embodiments, a subject treated for ASMD in accordance with the invention provided herein is a human that has not had a major organ transplant (e.g., liver or bone marrow transplant). In other embodiments, a subject treated for ASMD in accordance with the invention provided herein is a human that has had a major organ transplant (e.g., liver or bone marrow transplant). In some embodiments, a subject treated for ASMD in accordance with the

invention provided herein is a human that has not had a total or partial splenectomy. In other embodiments, a subject treated for ASMD in accordance with the invention provided herein is a human that has had a total or partial splenectomy.

[0146] In certain embodiments, a subject treated for ASMD in accordance with the invention provided herein is a human that does not have or has not been diagnosed with one or more of the following: active hepatitis B, active hepatitis C, human immunodeficiency virus (HIV) infection, cirrhosis, or significant cardiac disease (e.g., moderate or severe pulmonary hypertension or valvular dysfunction, or less than 50%, less than 40%, less than 30% or less than 20% left ventricular ejection fraction by echocardiography). In other embodiments, a subject treated for ASMD in accordance with the invention provided herein is a human that has or has been diagnosed as having one or more of the following: active hepatitis B, active hepatitis C, an human immunodeficiency virus (HIV) infection, cirrhosis, or significant cardiac disease (e.g., moderate or severe pulmonary hypertension or valvular dysfunction, or less than 50%, less than 40%, less than 30% or less than 20% left ventricular ejection fraction by echocardiography).

[0147] In certain embodiments, a subject treated for ASMD in accordance with the invention provided herein is a human that does not have one or more of the following: an International Normalized Ratio (INR) of greater than 1.25, 1.5, 1.75 or 2, a platelet count of less than 60×10^3 per μL , an alanine aminotransferase (ALT) of greater than 250 IU/L, an aspartate aminotransferase of greater than 250 IU/L, or a total bilirubin greater than 1.5 mg/dL, 1.75 mg/dL or 2 mg/dL. In other embodiments, a subject treated for ASMD in accordance with the invention provided herein is a human that has one or more of the following: an International Normalized Ratio (INR) of greater than 1.25, 1.5, 1.75 or 2, a platelet count of less than 60×10^3 per μL , an alanine aminotransferase (ALT) of greater than 250 IU/L, an aspartate aminotransferase of greater than 250 IU/L, or a total bilirubin greater than 1.5 mg/dL, 1.75 mg/dL or 2 mg/dL.

[0148] In certain embodiments, a subject treated for ASMD in accordance with the invention provided herein is a human that is not taking one or more of the following medications: chlorpromazine, imipramine or desipramine. In other embodiments, a subject treated for ASMD in accordance with the invention provided herein is a human that is taking one or more of the following medications: chlorpromazine, imipramine or desipramine.

[0149] In certain embodiments, a subject treated for ASMD in accordance with the invention provided herein is a human that is not taking herbal supplements or medications that may cause or prolong bleeding (e.g., anti-coagulants, ibuprofen, aspirin, garlic supplements, ginkgo, and ginseng), or have potential hepatotoxicity (e.g., 3-hydroxy-3-methyl glutaryl [HMG]-CoA reductase inhibitors, erythromycin, valproic acid, anti-depressants, kava and echinaecea). In other embodiments, a subject treated for ASMD in accordance with the invention provided herein is a human that is taking one or more of the following herbal supplementals or medications: anti-coagulants, ibuprofen, aspirin, garlic supplements, ginkgo, ginseng, 3-hydroxy-3-methyl glutaryl [HMG]-CoA reductase inhibitors, erythromycin, valproic acid, anti-

depressants, kava and echinaecea.

[0150] In specific embodiments, a subject treated for ASMD in accordance with the invention provided herein is human that meets one, two or more, or all of the criteria for subjects in the working examples in Sections 6, 8, and 9 *et seq.*

5.3. MONITORING TREATMENT

[0151] In accordance with the invention provided herein, a number of parameters (*e.g.*, factors or markers) can be monitored before, during and/or after the administration of a dose of ASM. In certain embodiments, a physical examination is performed prior to administration of ASM and as needed or recommended during the course of treatment with ASM. A physical examination can include the following assessments: general appearance, skin, head, ears, eyes, nose, and throat (HEENT), lymph nodes, heart, lungs, abdomen, extremities/joints, neurological, mental status, and reflexes. In certain embodiments, vital signs, continuous heart rate, respiratory rate, temperature and oxygen saturation can be assessed before, during and/or after the administration of a dose of ASM. Heart rates can be monitored continuously by telemetry beginning, *e.g.*, 6 hours before administration of a dose of ASM up to 72 hours after administration of a dose of ASM.

[0152] In specific embodiments, a complete blood count with differential, blood urea nitrogen (BUN), bicarbonate, creatinine, glucose, uric acid, calcium, phosphate, albumin, total protein, sodium, potassium, chloride, lactate dehydrogenase, creatine kinase, creatine kinase with MB fraction, and urinalysis (including urine color, appearance, specific gravity, pH, protein, glucose, ketones, bilirubin, hemoglobin, and microscopy if indicated) can be performed at the times specified before, during and/or after the administration of a dose of ASM. In certain embodiments, liver tests, coagulation studies, and/or fasting lipid profile can be performed before, during and/or after the administration of a dose of ASM. Liver functions tests can include assessing concentrations of alanine aminotransferase (ALT), aspartate aminotransferase (AST), alkaline phosphatase (AP), gamma-glutamyl transferase (GGT) and total and direct bilirubin. Coagulation studies can include assessing prothrombin time (PT), partial thromboplastin time (PTT), International normalized ratio (INR), D-dimer concentration, and fibrinogen concentration. Fasting lipid profile assessments can include assessments of total cholesterol (TC), low-density lipoprotein (LDL), high-density lipoprotein (HDL), very low-density lipoprotein (VLDL) and triglycerides.

[0153] In certain embodiments, a skin biopsy is performed prior to, during and/or subsequent to the administration of a dose of ASM. In some embodiments, a liver biopsy is performed prior to, during and/or subsequent to the administration of a dose of ASM. Sphingomyelin levels in skin and liver biospsies can be assessed by metamorph histological analysis.

[0154] In certain embodiments, pulmonary function tests are performed prior to, during and/or after the administration of a dose of ASM. Pulmonary function testing equipment calibration and

test administration protocols can be standardized accordance with American Thoracic Society (ATS) guidelines (ATS, 1991, Am Rev Respir Dis 144: 1202-1218). In certain embodiments, percent predicted forced vital capacity (FVC) is assessed prior to, during and after the administration of a dose of ASM. FVC is the total volume of air expired during a forced maneuver. The FVC can be measured using standard spirometric techniques.

[0155] In certain embodiments, forced expiratory volume in 1 second (FEV1) can be performed prior to, during and after the administration of a dose of ASM. FEV1 is the volume of air expelled during the first second of FVC. The FEV1 can be measured using standard spirometric techniques.

[0156] In certain embodiments, total lung capacity (TLC) can be assessed prior to, during and after the administration of a dose of ASM. TLC is the total volume of air within the lungs following a maximal inspiratory effort. The TLC can be measured using whole body plethysmography.

[0157] In certain embodiments, DLco can be assessed prior to, during and after the administration of a dose of ASM. DLco measures the rate of diffusion of a diffusion-limited gas (carbon monoxide, CO) per minute across the alveolocapillary membrane. DLco can be calculated by comparing the amount of carbon monoxide (CO) exhaled following a known amount of inhaled CO. Helium, which does not diffuse across the alveolocapillary membrane, can be included as a tracer with the inspired CO to control for air trapping.

[0158] In certain embodiments, a chest X-ray (posterior-anterior and lateral) can be obtained prior to, during and/or after the administration of a dose of ASM. In certain embodiments, an abdominal MRI is obtained before, during and/or after the administration of a dose of ASM.

[0159] In certain embodiments, a blood sample is collected before, during and/or after administration of a dose of ASM for assessment of biomarkers, bilirubin concentration, and the percentage of neutrophils of total white blood cells. In a specific embodiment, the concentration of one or more of the following biomarkers is assessed using techniques known to one skilled in the art: CRP/hs-CRP concentration, sphingomyelin concentration, iron concentration, ferritin concentration, calcitonin concentration, albumin concentration, SAA, serum amyloid P component, ACE, CCL18, chitotriosidase, transferrin, fibrinogen concentration, and plasma sphingomyelin concentration, plasma ceramide concentration. In certain embodiments, the concentration of one or more of the following cytokines is assessed using techniques known to one skilled in the art: IL-6 and IL-8.

[0160] In certain embodiments, the concentration of antibodies against ASM (e.g., anti-recombinant human ASM IgG and/or anti-recombinant human ASM IgE) is assessed before, during and/or after the administration of a dose of ASM. In some embodiments, the concentration of one, two or more complement factors are assessed before, during and/or after the administration of a dose of ASM. In certain embodiments, the concentration of serum tryptase is assessed before, during and/or after the administration of a dose of ASM. In certain embodiments, a skin test to determine IgE-mediated reactions to ASM is assessed before,

during and/or after the administration of a dose of ASM.s.

[0161] In certain embodiments, the pharmacokinetic profile for ASM is measured before, during and/or after the administration of a dose of ASM. In some embodiments, the BAL cell count is measured before, during and/or after the administration of a dose of ASM. See Section 8 *et seq, infra*, for other parameters that may be assessed before, during and/or after the administration of a dose of ASM.

[0162] In certain embodiments, a factor or marker described herein is assessed 1 week, 72 hours, 48 hours, 24 hours, 12 hours, 6 hours, 4 hours, 2 hours, 1 hour, 30 minutes or 15 minutes before the administration of a dose of ASM. In some embodiments, a factor or marker described herein is assessed during the administration of a dose of ASM. For example, a factor or marker described herein is assessed during the administration of a dose of ASM. In certain embodiments, a factor or marker described herein is assessed 15 minutes, 30 minutes, 1 hour, 2 hours, 4 hours, 6 hours, 8 hours 12 hours, 16 hours, 18 hours, 24 hours, 36 hours, 48 hours, 72 hours, 4 day, 5 days, 6 days, 1 week, two weeks, three weeks, four weeks, one month, two months, three months or longer after the administration of a dose of ASM. In certain embodiments, a factor or marker described herein is assessed some many hours or weeks after a certain number of doses of ASM. For example, a factor or marker described herein may be assessed every four weeks, month, 2 months, 3 months, 4 months, 5 months or 6 months after a certain number of doses of ASM. In certain embodiments, a factor or marker is assessed every 4 weeks, month, 2 months, 3 months, 4 months 5 months, 6 months, 7 months, 8 months, 9 months, 10 months, 11 months, or 12 months. In some embodiments, a factor or marker is assessed every month to 2 months, every month to 4 months, every 2 months to 4 months, every 2 months to 4 months, every 3 months to 4 months, every 2 months to 5 months, every 3 months to 5 months, every 4 months to 5 months, every 2 months to 6 months, every 3 months to 6 months, every 4 months to 6 months, or every 5 months to 6 months. In certain embodiments, a factor or marker is assessed every 6 months to 8 months, every 6 months to 12 months, every 8 months to 12 months, every 9 months to 12 months, or every 10 months to 12 months. In some embodiments, one or more factors or markers described herein is not assessed before, during and/or after the administration of a dose of ASM.

[0163] In certain embodiments, the results from the assessment of one or more factors or markers indicates that the dosage of ASM should be adjusted.

5.4. BIOLOGICAL SAMPLES

[0164] In accordance with the methods described herein, a biological sample is subjected to one or more pretreatment steps prior to the detection and/or measurement of a cell population, factor or marker (e.g., biomarker). In certain embodiments, a biological fluid is pretreated by centrifugation, filtration, precipitation, dialysis, or chromatography, or by a combination of such pretreatment steps. In other embodiments, a tissue sample is pretreated by freezing, chemical fixation, paraffin embedding, dehydration, permabilization, or homogenization followed by

centrifugation, filtration, precipitation, dialysis, or chromatography, or by a combination of such pretreatment steps. In certain embodiments, the sample is pretreated by removing cells of a certain type from the sample, or removing debris from the sample prior to the determination of the number or amount of a particular cell type(s) in the sample according to the methods described herein.

[0165] The biological sample can be a tissue sample, biological fluid, discharge, or any other sample from a human subject. In some embodiments, the biological sample is a blood sample or bone marrow sample. In certain embodiments, the biological sample is a tissue sample (*e.g.*, a liver, skin or lung biopsy). In some embodiments, the biological sample is a biological fluid such as urine. In certain embodiments, the biological sample is a sputum or nasal discharge sample. In some embodiments, the biological sample is mouth swab.

[0166] Techniques known in the art can be used to assess the presence, number, amount or percentage of a certain type(s) of cells present in a biological sample. For example, cells can be sorted using a fluorescence activated cell sorter (FACS). Fluorescence activated cell sorting (FACS) is a known method for separating particles, including cells, based on the fluorescent properties of the particles. See, for example, Kamarch, 1987, *Methods Enzymol* 151:150-165. Laser excitation of fluorescent moieties in the individual particles results in a small electrical charge allowing electromagnetic separation of positive and negative particles from a mixture. An antibody or ligand used to detect an antigenic determinant present on the cell surface of particular cells is labeled with a fluorochrome, such as FITC or phycoerythrin. The cells are incubated with the fluorescently labeled antibody or ligand for a time period sufficient to allow the labeled antibody or ligand to bind to cells. The cells are processed through the cell sorter, allowing separation of the cells of interest from other cells. FACS sorted particles can be directly deposited into individual wells of microtiter plates to facilitate separation.

[0167] Magnetic beads can be also used to separate cells. For example, cells can be sorted using a magnetic activated cell sorting (MACS) technique, a method for separating particles based on their ability to bind magnetic beads (0.5-100 μm diameter). A variety of useful modifications can be performed on the magnetic microspheres, including covalent addition of an antibody which specifically recognizes a cell-solid phase surface molecule or hapten. A magnetic field is then applied, to physically manipulate the selected beads. In a specific embodiment, antibodies to a blood cell surface marker are coupled to magnetic beads. The beads are then mixed with the blood cell culture to allow binding. Cells are then passed through a magnetic field to separate out cells having the blood cell surface markers of interest. These cells can then be isolated.

[0168] In some embodiments, the surface of a culture dish may be coated with antibodies, and used to separate cells by a method called panning. Separate dishes can be coated with antibody specific to particular cells. Cells can be added first to a dish coated with blood cell specific antibodies of interest. After thorough rinsing, the cells left bound to the dish will be cells that express the cell markers of interest. Examples of cell surface antigenic determinants or markers include, but are not limited to, CD2 for T lymphocytes and natural killer cells, CD3 for T lymphocytes, CD11a for leukocytes, CD28 for T lymphocytes, CD19 for B lymphocytes, CD20 for

B lymphocytes, CD21 for B lymphocytes, CD22 for B lymphocytes, CD23 for B lymphocytes, CD29 for leukocytes, CD 14 for monocytes, CD41 for platelets, CD61 for platelets, CD66 for granulocytes, CD67 for granulocytes and CD68 for monocytes and macrophages.

[0169] The presence, concentration or amount of a marker (including a biomarker) or factor can be assessed used techniques known in the art. The presence, concentration or amount of a marker (including a biomarker) or factor can be measured at the protein level and/or RNA level using techniques known to one skilled in the art. At the protein level, immunoassays, such as ELISAs and immunoprecipitation and western blots can be used to measure the presence, concentration or amount of a marker (including a biomarker) or factor. In addition, FACS can be used to measure the presence, concentration or amount of a marker (including a biomarker) or factor. At the RNA level, RT-PCR and Northern blots can be used to measure the presence, concentration or amount of a marker (including a biomarker) or factor.

5.5. CO-THERAPIES

[0170] In some embodiments an ASM for use in a method for treating ASMD involves the administration of ASM in combination with one or more additional therapies. As used herein, the term "in combination," refers, in the context of the administration of ASM, to the administration of a dose ASM prior to, concurrently with, or subsequent to the administration of one or more additional therapies (e.g., agents) for use in treating ASMD. The use of the term "in combination" does not restrict the order in which ASM and one or more additional therapies are administered to a subject. In specific embodiments, the interval of time between the administration of a dose of ASM and the administration of one or more additional therapies may be about 1-5 minutes, 1-30 minutes, 30 minutes to 60 minutes, 1 hour, 1-2 hours, 2-6 hours, 2-12 hours, 12-24 hours, 1-2 days, 2 days, 3 days, 4 days, 5 days, 6 days, 7 days, 1 week, 2 weeks, 3 weeks, 4 weeks, 5 weeks, 6 weeks, 7 weeks, 8 weeks, 9 weeks, 10 weeks, 15 weeks, 20 weeks, 26 weeks, 52 weeks, 11-15 weeks, 15-20 weeks, 20-30 weeks, 30-40 weeks, 40-50 weeks, 1 month, 2 months, 3 months, 4 months 5 months, 6 months, 7 months, 8 months, 9 months, 10 months, 11 months, 12 months, 1 year, 2 years, or any period of time in between. In certain embodiments, a dose ASM and one or more additional therapies are administered less than 1 day, 1 week, 2 weeks, 3 weeks, 4 weeks, one month, 2 months, 3 months, 6 months, 1 year, 2 years, or 5 years apart.

[0171] In some embodiments, the combination therapies provided herein involve administering a dose of ASM every 2 to 4 weeks, and administering one or more additional therapies once a week, once every 2 weeks, once every 3 weeks, once every 4 weeks, once every month, once every 2 months (e.g., approximately 8 weeks), once every 3 months (e.g., approximately 12 weeks), or once every 4 months (e.g., approximately 16 weeks). In certain embodiments, ASM and one or more additional therapies are cyclically administered to a subject. Cycling therapy involves the administration of ASM for a period of time, followed by the administration of one or more additional therapies for a period of time, and repeating this sequential administration. In certain embodiments, cycling therapy may also include a period of rest where ASM or the

additional therapy is not administered for a period of time (*e.g.*, 2 days, 3 days, 4 days, 5 days, 6 days, 7 days, 1 week, 2 weeks, 3 weeks, 4 weeks, 5 weeks, 10 weeks, 20 weeks, 1 month, 2 months, 3 months, 4 months, 5 months, 6 months, 7 months, 8 months, 9 months, 10 months, 11 months, 12 months, 2 years, or 3 years). In an embodiment, the number of cycles administered is from 1 to 12 cycles, from 2 to 10 cycles, or from 2 to 8 cycles.

[0172] In some embodiments an ASM for use in the methods for treating ASMD provided herein comprise administering ASM as a single agent for a period of time prior to administering ASM in combination with an additional therapy. In certain embodiments an ASM for use in the methods for treating ASMD provided herein comprise administering an additional therapy alone for a period of time prior to administering ASM in combination with the additional therapy.

[0173] In some embodiments, the administration of ASM and one or more additional therapies in accordance with the methods presented herein have an additive effect relative the administration of ASM or said one or more additional therapies alone. In some embodiments, the administration of ASM and one or more additional therapies in accordance with the methods presented herein have a synergistic effect relative to the administration of ASM or said one or more additional therapies alone.

[0174] As used herein, the term "synergistic," refers to the effect of the administration of a dose ASM in combination with one or more additional therapies (*e.g.*, agents), which combination is more effective than the additive effects of any two or more single therapies (*e.g.*, agents). In a specific embodiment, a synergistic effect of a combination therapy permits the use of lower dosages (*e.g.*, sub-optimal doses) of ASM or an additional therapy and/or less frequent administration of ASM or an additional therapy to a subject. In certain embodiments, the ability to utilize lower dosages of ASM or of an additional therapy and/or to administer ASM or said additional therapy less frequently reduces the toxicity associated with the administration of ASM or of said additional therapy, respectively, to a subject without reducing the efficacy of ASM or of said additional therapy, respectively, in the treatment of ASMD. In some embodiments, a synergistic effect results in improved efficacy of ASM and each of said additional therapies in treating ASMD. In some embodiments, a synergistic effect of a combination of ASM and one or more additional therapies avoids or reduces adverse or unwanted side effects associated with the use of any single therapy.

[0175] In particular embodiments, one or more additional therapies are administered in combination with ASM to subjects to reduce or ameliorate one or more of the following that may be associated with the administration of a particular dose of ASM: (i) a related adverse event, (ii) a total bilirubin value greater than the bilirubin value for a human without ASMD (*e.g.*, a healthy human), (iii) a plasma ceramide concentration greater than the plasma ceramide concentration of a human without ASMD (*e.g.*, a healthy human), or (iv) an acute phase response. In specific embodiments, one or more additional therapies are administered in combination with ASM to subjects to increase pulmonary function while minimizing one or more of the following that may be associated with the administration of a particular dose of ASM: (i) a related adverse event, (ii) a total bilirubin value greater than the bilirubin value for a human without ASMD (*e.g.*, a healthy human), (iii) a plasma ceramide concentration greater than the plasma ceramide concentration

of a human without ASMD (e.g., a healthy human), or (iv) an acute phase response.

[0176] In certain embodiments, one or more additional therapies administered in combination with ASM to a subject to control or relieve symptoms associated with ASMD. In some embodiments, one or more additional therapies that are administered in combination with ASM to a subject are pain relievers. Specific examples of therapies can be administered in combination with ASM include, but are not limited to, N-Acetyl-L-cysteine (NAC), S-Adenosyl-L-methionine (SAM), interleukin (IL)-6 antibody, IL-6 receptor antibody, dexamethasone, L-Nil, (a selective inhibitor of inducible NOS), L-NAME (a selective inhibitor of NOS), basic fibroblast growth factor (b-FGF), imipramine (a sphingomyelinase inhibitor), D609 (a sphingomyelinase inhibitor), and N-oleoylethanolamine (NOE; a ceramide inhibitor).

[0177] In certain embodiments, chaperones, such as small molecule chaperones, are administered in combination with ASM. See, e.g., U.S. Patent No. 7,750,050 and International Publication Nos. WO 2004/045574 and WO 2010/015816, which are incorporated by reference herein, for agents (e.g., small molecules) that may be administered in combination with ASM to a subject. In some embodiments, the chaperone (e.g., small molecule chaperone) does one, two or all of the following: increases the targeting of ASM to sites of pathology, stabilizes the activity of the ASM, and enhances the activity of the ASM.

[0178] In some embodiments, a glucocorticosteroid, such as dexamethasone, are administered in combination with ASM. See, e.g., U.S. Patent No. 7,658,916 for agents (e.g., glucocorticosteroids) that can be administered in combination with ASM.

[0179] In some embodiments, a substrate reduction molecule is administered in combination with ASM to a subject. In specific embodiments, a molecule (e.g., a small molecule) that either decreases the amount of sphingomyelin, reduces the rate of sphingomyelin synthesis, or both is administered in combination with ASM to a subject. See, e.g., Li et al. 2007, *Biochim Biophys Acta* 1771(9):1186-1194 for sphingomyelin synthase inhibitors, such as tricyclodecan-9-yl-xanthogenate and sphingomyelin synthase siRNAs.

[0180] In some embodiments, a therapy that reduces the potential immunogenicity of ASM is administered in combination with ASM to a subject. In certain embodiments, benedryl is administered in combination with ASM to a subject.

[0181] The combination of ASM and one or more additional therapies can be administered to a subject in the same pharmaceutical composition. Alternatively, ASM and one or more additional therapies can be administered concurrently to a subject in separate pharmaceutical compositions. ASM and one or more additional therapies can be administered sequentially to a subject in separate pharmaceutical compositions. ASM and one or more additional therapies may also be administered to a subject by the same or different routes of administration.

5.6. PHARMACEUTICAL PRODUCTS

[0182] In one aspect, described herein are finished packaged and labeled pharmaceutical products. In one embodiment, a pharmaceutical product comprises a unit dosage form of ASM in an appropriate vessel or container (e.g., a glass vial or other container that is hermetically sealed). In some embodiments, the unit dosage form is a lyophilized form of ASM, and under those circumstances, the pharmaceutical product may contain a second container with sterile saline or sterile water for reconstituting the lyophilized form of ASM. In other embodiments, the unit dosage form is an aqueous form of ASM that does not require reconstitution before administration to a subject. In specific embodiments, the unit dosage form of ASM contains ASM in an amount sufficient for the administration of a low, non-toxic dose of the enzyme to a subject. In certain embodiments, the unit dosage form is suitable for the selected route of administration of the ASM to the subject. In a specific embodiment, the unit dosage form is suitable for intravenous delivery to a subject.

[0183] In one embodiment, a pharmaceutical product comprises a unit dosage form of ASM in an appropriate vessel or container (e.g., a glass vial or other container that is hermetically sealed) and an infusion pump or syringe pump for the administration of the ASM to a subject.

[0184] As with any pharmaceutical product, the packaging material and container are designed to protect the stability of the product during storage and shipment. Further, the pharmaceutical product includes instructions for use or other informational material that advise the physician, technician or patient on how to appropriately treat ASMD. In other words, the pharmaceutical product includes instruction means indicating or suggesting a dosing regimen including, but not limited to, actual doses (e.g., a dose escalation protocol), monitoring procedures, and other monitoring information. In certain embodiments, the pharmaceutical produce includes a means for genotyping a patient (e.g., PCR primers for the SMPD1 gene).

6. EXAMPLE 1: HUMAN TRIAL OF RECOMBINANT HUMAN ACID SPHINGOMYELINASE (RHASM) ENZYME REPLACEMENT THERAPY IN HUMAN ADULTS WITH ASM DEFICIENCY

6.1. INTRODUCTION

[0185] ASMD is an autosomal recessive, lysosomal storage disorder that results when sphingomyelin is unable to be normally catabolized to ceramide and phosphorylcholine. Consequently, sphingomyelin accumulates within cells primarily of the reticuloendothelial system, leading to hepatosplenomegaly, anemia, thrombocytopenia, and interstitial lung disease. Growth retardation and an atherogenic lipid profile also are common findings. Patients who have little to no residual ASM activity exhibit the most severe symptoms with onset in infancy, failure to thrive, neurodegeneration, and death by age 3 (Niemann-Pick disease type A, NPD A). Patients with higher amounts of residual ASM activity have variable ages of onset, heterogeneous presentations and somatic symptoms, little to no neurologic involvement, and generally survive into adulthood (NPD B). Currently, there is no treatment for patients with

ASMD.

[0186] Enzyme replacement therapy (ERT) has been successfully used to treat several lysosomal storage disorders, including Gaucher disease, Mucopolysaccharidosis types I, II, and VI, Fabry disease, and Pompe disease. Recombinant human lysosomal enzymes are administered intravenously and taken up into cells by receptor-mediated endocytosis for subsequent targeting to lysosomes. Proof of principle for the treatment of ASMD was demonstrated by Dr. Edward Schuchman's laboratory (Mount Sinai Medical Center) in an ASM knockout mouse (ASMKO) model where intravenous injections of recombinant human ASM (rhASM) efficiently reduced sphingomyelin levels in liver and spleen, and to a lesser extent in lung (Miranda, et al., FASEB 2000;14:1988). However, sphingomyelin levels were not reduced in brain because of the inability of rhASM to cross the blood-brain barrier. Due to the fact that the ASMKO mouse has no residual ASM activity or protein and develops rapid and severe neurological disease, this animal is considered most appropriately a model of NPD - type A (see, Buccinna et al., 2009, J. Neurochem. 109:105-115).

[0187] Additional studies confirmed that biweekly doses of rhASM reduced sphingomyelin levels in ASMKO mice in a dose-dependent manner (0.3-3 mg/kg). The no observed adverse effect levels (NOAEL) for single and repeat dosing were determined to be 0.3 and 3 mg/kg, respectively in ASMKO mice. Subsequent attempts to deplete sphingomyelin levels in lung with higher doses of rhASM led to unexpected toxicity. At doses ≥ 10 mg/kg, ASMKO mice but not normal animals experienced liver inflammation, adrenal hemorrhage, cardiovascular shock and death in the setting of very elevated cytokine levels, suggesting cytokine release syndrome. The toxicity and cytokine elevations seen with high doses of rhASM could be ameliorated or prevented by prior treatment of ASMKO mice with several lower doses of rhASM, suggesting that the rate and amount of sphingomyelin degradation plays a key role.

[0188] In the ASMKO mouse, a model for NPD-type A, toxicity was not observed following single doses of ≤ 0.3 mg/kg rhASM and repeat doses of ≤ 3.0 mg/kg rhASM; severe toxicity was not observed until single doses ≥ 10 mg/kg rhASM were administered. Therefore, a conservative starting dose of 0.03 mg/kg rhASM was selected for single-dose treatment of human subjects to ensure a 10-fold safety margin with respect to the single-dose NOAEL (0.3 mg/kg) observed in ASMKO mice. A maximum dose of 1.0 mg/kg rhASM was selected for single dose treatment of human subjects to ensure a 10-fold safety margin with respect to the dose at which serious toxicity was observed in the ASMKO mouse (10 mg/kg). Upon completion of the protocol set forth below, toxicity in the human subjects was unexpectedly observed with a dose as low as 0.3 mg/kg rhASM.

6.2. MATERIALS AND METHODS

6.2.1. HUMAN PROTOCOL DESIGN

[0189] This protocol was a single-center, single-dose, dose escalation Phase 1 trial. The primary trial objectives were to evaluate the safety and pharmacokinetics of single doses of rhASM in human adults with non-neuronopathic ASMD (Niemann-Pick B). Single doses of 0.03, 0.1, 0.3, 0.6 and 1.0 mg/kg rhASM were infused sequentially by dose cohort. The original trial design called for a minimum of 15 patients (5 cohorts of 3 patients each). Due to difficulties with patient enrollment, the protocol was amended such that the first 2 cohorts enrolled 3 patients each and the last 3 cohorts were to enroll 2 patients each. An independent data monitoring committee oversaw the conduct of the trial and all protocol procedures were approved by the IRB. Figure 1 depicts the protocol patient flow.

6.2.2. PATIENTS

[0190] To be eligible for the protocol, patients had to be 18-65 years of age and have deficient ASM enzyme activity, a spleen volume $\geq 2x$ normal, AST and ALT ≤ 250 IU/L, bilirubin ≤ 3.6 mg/dL, INR ≤ 1.5 , DLco $>30\%$ predicted, and platelets $\geq 60,000$ /mL. Patients were excluded if they had cirrhosis (by liver biopsy), significant cardiac disease, total splenectomy, or were taking medications or herbal supplements that were potentially hepatotoxic, promoted bleeding, or inhibited rhASM.

[0191] A total of 13 patients were enrolled and 11 patients infused with rhASM. rhASM was produced by over-expression of ASM cDNA in Chinese hamster ovary cells. The mean age of infused patients was 30.8 yrs, all were Caucasian (non-Hispanic/non-Latino), and mean spleen volume was 10.8 multiples of normal. One had a partial splenectomy; the remaining patients had intact spleens at protocol entry. Figure 2 depicts the demography and baseline characteristics of the patients in this protocol.

[0192] Once screening was completed and eligibility was confirmed, patients were admitted to the cardiac care unit (CCU) overnight for baseline telemetry and infused the following morning with rhASM. Patients were monitored for 72 hrs post-dose while on telemetry (24 hrs in the CCU and 48 hrs in the General Clinical Research Center). Patients returned for an overnight visit on Day 14 and an outpatient visit on Day 28.

[0193] The following sets forth the medical assessments that were made during the protocol:

- Physical exam - Days 0, 1, 2, 14, and 28
- Chemistries, hematology, and urinalysis - preinfusion, then 24, 48, 72 hrs; Days 14, 28
- Liver function tests - preinfusion, then q12 hrs through 72 hrs, Days 14, 28, Aldosterone, cortisol, delta-4-androstenedione - preinfusion, then q12 hrs through 72 hrs
- ACTH stimulation test - Screening, Day 14 Telemetry - continuous through 72 hrs ECG, echocardiogram -preinfusion, end of infusion, and postinfusion at 1, 2, 6, 12, and 4 hrs, Day 14
- Cardiac biomarkers (BNP, cardiac troponin-I, CPK-MB) - preinfusion, then 2, 6, 12, 24 hrs
- Sphingomyelin, ceramide levels in plasma - preinfusion, then 24, 48, 72 hrs; Days 14 and 28

- Pulmonary function testing and CXR - Screening, Day 14
- Liver and spleen volumes by MRI - Screening, Day 14
- Liver and skin biopsies - Screening, Day 14
- Biomarkers - predose, Days 14, 28
- Anti-rhASM IgG testing - preinfusion, Day 28
- Pharmacokinetics - within 30 min preinfusion, 15 min after start of infusion, end of infusion, and at following time points post-infusion: 15 min, 30 min, 45 min; 1 hr., 2, 3, 4, 6, 8, 12, 18, 24, 48, 72 hrs.
- Cytokines (IL-1a, IL-1b, IL-6, G-CSF, GM-CSF, MIP-1a, TNF-a) - pharmacokinetic time points (above) plus Day 14

6.3. RESULTS

[0194] As depicted in Figures 3A and 3B, plasma ceramide levels and plasma sphingomyelin levels, respectively, were determined at several time points. Plasma ceramide levels showed a dose-dependent rise by 6 hrs and peaked at 18-72 hrs. Plasma sphingomyelin levels were normal at baseline and showed no consistent trend over time. In patient no. 12112 who received the highest dose (1 mg/kg), the plasma sphingomyelin level rose post-dose and peaked at 72 hours.

[0195] Figure 4 depicts total bilirubin levels determined over several time points during the protocol. Total bilirubin showed a dose-related rise by 24 hrs and peaked at 48-60 hrs. The highest total bilirubin was 4.7 mg/dL in patient no. 12112 who received the highest dose (1 mg/kg). There were proportional increases in direct and indirect bilirubin. No increases were seen in ALT, AST, or alkaline phosphatase. There was a mild increase in GGT through 72 hrs (not shown) in two patients who received the highest (1 mg/kg, patient no. 12112) and lowest (0.03 mg/kg, patient no. 10503) doses. Hemoglobin and hematocrit levels were stable through the protocol, indicating that hemolysis was not responsible for elevated bilirubin levels.

[0196] Figures 5A-5G depict the levels of acute phase response (inflammation) markers, CRP/hs-CRP, % neutrophils, fibrinogen, ferritin, IL-8, IL-6, and calcitonin, respectively, determined at several time points for several patients. CRP/hs-CRP showed a transient dose-related rise by 24 hrs, peaked at 48-72 hrs, and returned to normal by Day 14. Other acute phase reactants also showed increases (% neutrophils, fibrinogen, ferritin, PT and PTT) and decreases (iron, albumin). Certain inflammatory biomarkers, e.g., the cytokines IL-6 and IL-8, and calcitonin, also showed substantial elevations that were dose dependent and peaked 48 hours post-infusion. Among these inflammatory mediators, the greatest changes in descending order occurred in IL 8 (peak 33.8× upper limit of normal), calcitonin (peak 33.4× upper limit of normal), CRP (peak 9.8 × upper limit of normal), and ferritin (3.9× upper limit of normal). There was no trend in platelet count or the level of fibrin-split products (not shown). The rises in

laboratory acute phase reactants correlated with the constitutional clinical symptoms of fever, nausea, vomiting, headache, pain, and myalgias in some patients.

[0197] Figure 6 is a chart of treatment emergent adverse events for four patients each on a different dose of rhASM, which events were considered to be related (possibly, probably, or definitely) to treatment. As set forth in the chart, patient no. 11509, who was given a dose of 0.3 mg/kg rhASM, exhibited moderately severe adverse events starting on day 2.

[0198] With regard to related adverse events reported in the protocol, there were no significant cardiovascular changes by telemetry, ECG, echocardiogram, or biomarkers (BNP, cardiac troponin-I, CPK-MB) or adrenal hormone dysfunction. One patient (no. 12112, 1.0 mg/kg cohort) had an elevated cortisol level in the morning 24 hours post-dose, which most likely represented a normal physiologic stress response to several ongoing moderate related adverse events. Further, four of six patients receiving ≥ 0.3 mg/kg rhASM experienced a total of 19 clinical and laboratory related adverse events assessed as drug-related. The intensity of related adverse events ranged from mild to severe, but most were moderate and did not require any intervention. They included fever (n=2), pain [myalgia; abdominal, leg, and hip pain] (n=2), nausea (n=2), scleral icterus and urine urobilinogen (n=1), fatigue (n=1), vomiting (n=1), lymphocytic infiltrate/hepatocellular degeneration on liver biopsy (n=1), acute phase reaction (n=4), elevated bilirubin (n=2), and increased fibrin D-dimer (n=1). The onset of clinical symptoms began 12 hours post-infusion and resolved by 72 hrs, except for hip pain in one patient that began after 72 hours. At day 14, a liver biopsy in one patient (0.6 mg/kg rhASM, patient no. 12313) showed two new foci of lymphocytic infiltrates: one was tiny (0.1 mm diameter), and the other was moderate (0.5 mm diameter) and which was associated with hepatocellular degeneration. This protocol was stopped when the first patient in cohort 5 (1 mg/kg rhASM, patient no. 12112) experienced a dose-limiting toxicity of hyperbilirubinemia (peak 4.7 mg/dL).

[0199] The results of this showed an unexpected and delayed onset of dose-related clinical and laboratory adverse events in humans suffering from ASMD at doses of rhASM of 0.3 mg/kg and higher. Further, two major safety laboratory observations were made in view of the results of this protocol. One regarding hyperbilirubinemia, in which a proportionate to dose rise in direct and indirect bilirubin was observed with no consistent markers of liver damage (AST, ALT, AP) or evidence of hemolysis (hemoglobin and hematocrit). Two patients had mildly elevated GGT at 48-72 hours, and one patient had two new liver foci of lymphocytic infiltrates, one of which was associated with hepatocellular degeneration.

[0200] The other observation concerned the acute phase response, i.e., inflammation. The results showed an increase in CRP/hs-CRP, % neutrophils, ferritin, IL-6, IL-8, calcitonin, fibrinogen, PT, PTT, and a decrease in iron and albumin in response to increasing dosages of rhASM. The constitutional clinical symptoms of fever, nausea, vomiting, pain, and myalgia were most likely related to the acute phase response. The results showed no evidence of cytokine release syndrome associated with cardiovascular changes, and no evidence of adrenal hormone dysfunction.

6.4. CONCLUSIONS

[0201] The above-described protocol is the first experience with enzyme replacement therapy in adult human patients with ASMD. At bioactive doses in humans, rhASM did not cause cytokine release syndrome associated with cardiovascular changes, or cause adrenal hormone dysfunction. The major safety observations were dose-related hyperbilirubinemia and acute phase response. Both adverse events are likely related to the breakdown of sphingomyelin into ceramide and phospholcholine, but the exact molecular mechanisms are not fully understood. Several safety biomarkers were identified, including bilirubin, ceramide, CRP/hs-CRP, 1L-8, 1L-6, calcitonin, and ferritin. Further, based on the hyperbilirubinemia findings, the maximum tolerated starting dose of rhASM was 0.6 mg/kg.

[0202] Moreover, the fact that the onset of adverse events with clinical symptoms in patients was observed at a dose as low as 0.3 mg/kg was surprising, given that the NOAEL ("no observed adverse effect level") in the ASMKO mouse was 0.3 mg/kg. Notably, clinical symptoms of toxicity in the ASMKO mice was not observed until doses greater than or equal to 10 mg/kg were used.

7. EXAMPLE 2: REPEAT DOSE INTRAVENOUS INJECTION TOXICITY PROTOCOL FOLLOWING DEBULKING PHASE IN ACID SPHINGOMYELINEASE KNOCK-OUT MICE

[0203] This example describes the investigation of the potential toxicity of repeated intravenous administration of recombinant human acid sphingomyelinase (rhASM) following a debulking phase in acid sphingomyelinase knockout (ASMKO) mice. Having established that toxic side effects begin to be observed at initial doses of 10 mg/kg of rhASM in ASMKO mice, the following investigation was designed to determine if the administration of escalating doses of recombinant human acid sphingomyelinase (rhASM) in ASMKO mice would debulk enough of the accumulated sphingomyelin so that a higher dose of rhASM could be administered to the ASMKO mice to target sites of pathology, such as the lung and brain, with minimal or no observable toxicity.

[0204] JK ASMKO mice were administered 3 mg/kg rhASM on study days (SD) 1, 3, 5, 7 (Debulking Phase). Beginning on SD 9 and continuing every other week for 13 weeks (7 doses) mice received treatment doses of 3, 10, or 30 mg/kg rhASM (Treatment Phase).

[0205] rhASM was intravenously administered via a bolus injection in a lateral tail vein to male and female ASMKO mice. Groups 1-3 received 3 mg/kg rhASM during the Debulking Phase (SD 1, 3, 5 and 7). Groups 1, 2, and 3 received 3, 10 and 30 mg/kg rhASM, respectively, during the Treatment Phase (SD 9, 23, 37, 51, 65, 79, and 93). One subset of mice in each group (the first 2 mice/sex in Group 1 and the first 4 mice/sex in Groups 2-3) were bled pre-study as well as 5 minutes and 4 hours following Treatment Phase Doses 1, 4, and 7 for analysis of toxicokinetics (TK) (5 minutes) and ceramide levels (4 hours). The other subset of mice in each group (the last

2 mice/sex in Group 1 and the last 4 mice/sex in Groups 2-3) were bled pre-study as well as 4 and 24 hours following Treatment Phase Doses 1, 4, and 7 for analysis of rodent multi-analyte profiles (4 hours) and acute phase protein/liver function test levels (24 hours). See the Study Design in Table 2, *infra*.

[0206] Due to the likelihood of anaphylactic responses beginning with the first Treatment Phase dose and each dose thereafter, each mouse was observed closely for signs of anaphylaxis (e.g., restlessness, chewing, rubbing face, urticaria, edema, lethargy, and scruffy coat) following test article administration. Mice received diphenhydramine (DPH) beginning prior to the first dose of the Treatment Phase and each dose thereafter.

[0207] DPH at a concentration of 5 mg/mL was prepared by diluting a 50 mg/mL commercially-available stock solution with sterile 0.9% saline. DPH was administered intraperitoneally (IP) at a dose of 20 mg/kg (4 mL/kg) based on the most recent body weight, 10-20 minutes prior to dosing rhASM to prevent possible anaphylactic reactions. If any animal demonstrated a hypersensitivity reaction post-test article administration, despite DPH pre-treatment, a second dose of DPH was administered IP at 10 mg/kg (2 mL/kg).

[0208] All mice were euthanized via CO₂ asphyxiation on SD 100. Following euthanasia blood were collected for clinical pathology and immunogenicity analysis via a cardiac puncture. A necropsy was performed on all mice following blood collection. All tissues were preserved in 10% neutral buffered formalin (NBF) followed by histopathological analysis. A piece of the liver, spleen, kidney, and lung were preserved in 2% glutaraldehyde/2% paraformaldehyde for analysis of the sphingomyelin load. A piece of the liver, spleen, kidney, and lung were also collected and stored at ≤ -70°C for possible future analysis.

[0209] Following necropsy all remaining tissues including the carcass were placed in 10% NBF.

TABLE 2: STUDY DESIGN:

<u>Dose Identification</u>	<u>No. of Animals</u>		<u>Debulking Phase</u>	<u>Dose Level of rhASM Treatment</u>	<u>Dose Concentration of Treatment (mg/ml)</u>	<u>Dose Volume of Treatment (mL/kg)</u>
	Male	Female				
1 - rhASM*	4	4	All mice were administered 3 mg/kg rhASM on Study Days 1, 3, 5, and 7	3 mg/kg beginning on Study Day 9 and every other week thereafter for 13 weeks	0.39	7.7
2 - rhASM*	8	8		10 mg/kg beginning on Study Day 9	1.3	

<u>Dose Identification</u>	<u>No. of Animals</u>		<u>Debulking Phase</u>	<u>Dose Level of rhASM Treatment</u>	<u>Dose Concentration of Treatment (mg/ml)</u>	<u>Dose Volume of Treatment (mL/kg)</u>
	Male	Female				
			Doses were administered at a concentration of 0.39 mg/mL at a volume of 7.7 mL/kg	and every other week thereafter for 13 weeks		
3 - rhASM*	8	8		30 mg/kg beginning on Study Day 9 and every other week thereafter for 13 weeks	3.9	

* Diphenhydramine will be administered to all mice prior to the 1st Treatment Phase dose and each dose thereafter.

In Life Observations:

[0210] The first day of the study was considered SD1 (the first day of dosing). Animal body weights were taken once weekly during the course of the study beginning on SD-1 and were taken on the Monday of each week thereafter. Cageside observations were made once daily Monday through Friday. Any abnormalities and observations of normal were recorded. Post-dose clinical observations/scoring were made immediately prior to, 10-20, and 50-70 minutes following each dose administration. Any abnormalities and observations of normal were recorded. The attending veterinarian and/or the study director was consulted in the event of an adverse reaction and appropriate actions were taken based on their recommendations.

Euthanasia:

[0211] If there was an adverse reaction that affected the health and well being of an animal, then the animal was euthanized via CO2 asphyxiation, opened via the thoracic, abdominal, and cranial cavities and placed in 10% neutral buffered formalin (NBF) for possible future analysis. If an animal was found dead, the entire carcass was preserved in 10% NBF for possible future analysis. At the end of the study all surviving animals were euthanized by CO2 asphyxiation.

Sample Collection:

[0212] Dose Analysis: Approximately five-hundred microliters (500 µL) of test article from all dose levels was collected within 1-10 minutes following formulation on each day of dosing and stored on dry ice until transfer to a freezer set to maintain a temperature of ≤ -70°C. Dose analysis samples were transferred on SD 1, 3, 5, 7, 9, 23, 37, 51, 65, 79, and 93 and were stored at ≤ -70°C until analysis. Dose analysis samples were measured via the A280 assay.

[0213] Blood Collection: For the collection of blood for analysis of TK, rodent multi-analyte profiles, and acute phase protein/liver function test levels mice were anesthetized with a mixture of isoflurane and oxygen. Blood collections occurred on SD -1, 9, 51 and 93 (pre-study and the 1st, 4th, and 7th treatment phase doses, respectively) according to the Blood Collection Tables (see Tables 4 and 5, *infra*) and the following text.

rhASM Toxicokinetics: The first 2 mice/sex in Group 1 and the first 4 mice/sex in Groups 2-3 had a blood sample taken for analysis of peak rhASM levels pre-study (SD -1), and 5 minutes following the 1st, 4th, and 7th Treatment Phase doses. Blood from all animals was collected from the retro-orbital plexus of unconscious mice. Approximately 60 µL of whole blood was collected into hematocrit tubes and allowed to clot at room temperature for at least 1 minute. Serum were prepared from these samples by centrifugation for 5 minutes at 10,000 revolutions per minute (RPM). Following centrifugation the serum was collected and stored on dry ice until transfer to a freezer set to maintain a temperature of ≤ -70°C. Once transferred, all samples were stored at ≤ -70°C until analysis. TK samples were transferred on SD 1, 9, 51, and 93. TK samples were measured by an enzyme linked immunosorbent assay (ELISA).

Analysis of Ceramide Levels: The first 2 mice/sex in Group 1 and the first 4 mice/sex in Groups 2-3 had a blood sample taken for analysis of ceramide levels pre-study (SD -1), and 4 hours following the 1st, 4th, and 7th Treatment Phase doses. Blood from these animals was collected from the retro-orbital plexus of unconscious mice. Approximately 240 µL of whole blood was collected into potassium EDTA tubes and placed on a Nutator rocker for up to 30 minutes to prevent the formation of a clot. Plasma was prepared from these samples by centrifugation for 5 minutes at 10,000 RPM. Following centrifugation the plasma was collected and stored on dry ice until transfer to a freezer set to maintain a temperature of ≤ -70°C. Once transferred, all samples were stored at ≤ -70°C until analysis by a Mass Spectrometry Group. Ceramide samples were transferred no later than SD 94. Ceramide samples were measured by mass spectrometry.

Analysis of Rodent Multi-Analyte Profiles (MAP): The last 2 mice/sex in Group 1 and the last 4 mice/sex in Groups 2-3 had a blood sample taken for analysis of rodent multi-analyte profiles pre-study (SD -1), and 4 hours following the 1st, 4th, and 7th Treatment Phase doses. Blood from these animals was collected from the retro-orbital plexus in unconscious mice. Approximately 150 µL of whole blood was collected into serum separator tubes and allowed to clot for at least 30 minutes. Serum was prepared from these samples by centrifugation for 5 minutes at 10,000 RPM. Following centrifugation the serum was collected and stored on dry ice until transfer to a freezer set to maintain a temperature of ≤ -70°C. Once transferred, all samples were stored at ≤ -70°C until shipment on no later than SD 94 for analysis of rodent multi-analyte profiles. Samples were shipped to Rules Based Medicine on dry ice. The Rodent Multi-Analyte Profiles Table (see Table 3, *infra*) lists the analytes that were measured.

TABLE 3: Rodent Multi-Analyte Profiles:

Analytes to be Tested		
Apolipoprotein A1	Interleukin-2	MIP-3 beta
C-Reactive Protein	Interleukin-3	MMP-9
CD40	Interleukin-4	MCP-1
CD40 Ligand	Interleukin-5	MCP-3
Endothelin-1	Interleukin-6	MCP-5
Eotaxin	Interleukin-7	Myeloperoxidase
Epidermal Growth Factor	Interleukin-10	Myoglobin
Factor VII	Interleukin-11	Oncostatin M
Fibrinogen	Interleukin-12p70	RANTES
FGF-basic	Interleukin-17	Serum Amyloid P
FGF-9	KC/GRO alpha	SGOT
GCP-2	Leukemia Inhibitory Factor	Stem Cell Factor
GM-CSF	Lymphotactin	Thrombopoietin
GST-alpha	M-CSF	TIMP 1
Haptoglobin	MDC	Tissue Factor
Immunoglobulin A	MIP-1 alpha	Tumor Necrosis Factor-alpha
Inducible Protein-10	MIP-1 beta	VCAM-1
Interferon-gamma	MIP-1 gamma	VEGF
Interleukin-1 alpha	MIP-2	von Willebrand Factor
Interleukin-1 beta		

Analysis of Acute Phase Protein/Liver Function Test Levels: The last 2 mice/sex in Group 1 and the last 4 mice/sex in Groups 2-3 had a blood sample taken for analysis of acute phase protein (serum amyloid-A and serum amyloid-P) and liver function (bilirubin and alanine aminotransferase (ALT)) levels pre-study (SD -1), and 24 hours following the 1st, 4th, and 7th Treatment Phase doses. Blood from these animals was collected from the retro-orbital plexus in unconscious mice. Approximately 150 μ L of whole blood was collected into serum separator tubes and allowed to clot for at least 30 minutes. Serum was prepared from these samples by centrifugation for 5 minutes at 10,000 RPM. Following centrifugation the serum was collected and stored on dry ice until transfer to a freezer set to maintain a temperature of $\leq -70^{\circ}\text{C}$. Once transferred, all samples were stored at $\leq -70^{\circ}\text{C}$ until shipment no later than SD 94 for acute phase protein/liver function test analysis. Samples were shipped to Analytics on dry ice.

TABLE 4: Pre-Study (SD -1) Blood Collection Table

Group	Animal #	Sex	TK Pre-Bleed (60 μ L)	Rodent Map Pre-Bleed (150 μ L)	Ceramide Pre-Bleed (240 μ L)	APP/Liver Function Pre-Bleed (150 μ L)
	1,2	M	X		X	

Group	Animal #	Sex	TK Pre-Bleed (60 μ L)	Rodent Map Pre-Bleed (150 μ L)	Ceramide Pre-Bleed (240 μ L)	APP/Liver Function Pre-Bleed (150 μ L)
1	5,6	F	X		X	
	3,4	M		X		X
	7,8	F		X		X
2	9,10,11,12	M	X		X	
	17,18,19,20	F	X		X	
	13,14,15,16	M		X		X
	21,22,23,24	F		X		X
3	25,26,27,28	M	X		X	
	33,34,35,36	F	X		X	
	29,30,31,32	M		X		X
	37,38,39,40	F		X		X

TABLE 5: SD 9, 51, and 93 Blood Collection Table

Group	Animal #	Sex	TK Bleed (60 μ L)	Rodent Map Bleed (150 μ L)	Ceramide Bleed (240 μ L)	APP/Liver Function Bleed (150 μ L)
			5 Minutes Post-Dose	4 Hours Post-Dose	4 Hours Post-Dose	24 Hours Post-Dose
1	1,2	M	X		X	
	5,6	F	X		X	
	3,4	M		X		X
	7,8	F		X		X
2	9,10,11,12	M	X		X	
	17,18,19,20	F	X		X	
	13,14,15,16	M		X		X
	21,22,23,24	F		X		X
3	25,26,27,28	M	X		X	
	33,34,35,36	F	X		X	
	29,30,31,32	M		X		X

Necropsy

[0214] *Terminal Blood Collection for Analysis of Clinical Pathology and Immunogenicity:* Following euthanasia, all animals had a cardiac puncture performed for the collection of whole blood (approximately $\geq 500 \mu$ L) from all main study animals for clinical pathology and

immunogenicity analysis. Approximately 150 µL of the whole blood was placed in potassium EDTA tubes, and gently inverted for analysis of hematology parameters. Following the gentle inversion all samples were stored at room temperature rocking on a Nutator rocker until the samples were stored at 2-10°C until analysis. The remaining blood (from the cardiac stick following removal of 150 µL for hematology analysis) was placed in a serum separator tube, allowed to clot at room temperature for at least 30 minutes, spun in a centrifuge for 5 minutes at 10,000 RPM, and the serum will be collected. Approximately 30 µL of serum was placed in an eppendorf tube for immunogenicity analysis while the remaining serum was placed in an eppendorf tube for clinical chemistry analysis. The immunogenicity samples were stored on dry ice until they were stored in a freezer set to maintain a temperature of ≤ -70°C. Immunogenicity samples were measured by an ELISA. Clinical chemistry samples were placed on dry ice until all samples were stored at ≤ -20°C until analysis. The Hematology and Clinical Chemistry Analyte Table (see Table 6, *infra*) lists the analytes that were measured.

TABLE 6: Hematology and Clinical Chemistry Analyte Table:

Hematology Parameters	Clinical Chemistry Parameters
Leukocyte count (total and absolute differential)	alkaline phosphatase
erythrocyte count	total bilirubin (with direct bilirubin if total bilirubin exceeds 1 mg/dL)
Hemoglobin	aspartate aminotransferase
Hematocrit	alanine aminotransferase
mean corpuscular hemoglobin	gamma glutamyl transferase
mean corpuscular volume	urea nitrogen
mean corpuscular hemoglobin concentration (calculated)	Creatinine
Absolute reticulocytes	total protein
Platelet count	Albumin
blood cell morphology	globulin and A/G (albumin/globulin) ratio (calculated)
blood smear	Glucose
	total cholesterol
	Triglycerides
	Electrolytes (sodium, potassium, chloride)
	Calcium
	Phosphorus
Results from the analysis of hematology and clinical chemistry analyses from all animals was interpreted by a board certified pathologist.	

[0215] Tissue Collection: Following euthanasia on SD 100, all animals were subjected to necropsy for tissue collection. The necropsy included an examination of the external features of

the carcass, external body orifices, the abdominal and thoracic cavities, organs, and tissues. Gross findings were recorded. The Tissue Collection Table (see Table 7, *infra*) lists the tissues that were collected in 10% NBF. Gross lesions were also collected and stored in 10% NBF. The remaining carcass were preserved in 10% NBF.

TABLE 7: Tissue Collection Table:

Tissue	Tissue
adrenal (2)	Pancreas
Aorta	pituitary gland
Brain	Prostate
Cecum	Rectum
Colon	salivary gland [mandibular (2)]
Duodenum	seminal vesicle (2)
epididymus (2)	sciatic nerve
Esophagus	skeletal muscle (quadriceps)
eye with optic nerve (2)	Skin
femur with bone marrow (articular surface of the distal end)	spinal cord (cervical, thoracic and lumbar)
gall bladder	Spleen
Heart	sternum with bone marrow
Ileum	Stomach
Jejunum	testis (2)
kidney (2)	Thymus
Liver	thyroid (2) with parathyroid
lung with mainstem bronchi	Tongue
lymph node (mandibular)	Trachea
lymph node (mesenteric)	urinary bladder
mammary gland (females)	uterus with cervix
ovary (2)	gross lesions

Bolded samples will be weighed

[0216] Organ Weights: At the time of necropsy, the above bolded organs were weighed; paired organs were weighed together. Weights were recorded on the organ weight form. Organ-to-body weight percentages and organ-to-brain weight ratios were calculated based on the body weights taken prior to necropsy.

Histopathology: Samples from all animals as well as gross lesions from any animal on study were transferred to histology. Preserved tissues listed above from each animal were embedded

in paraffin. All tissues were sectioned, stained with hematoxylin and eosin, and were examined microscopically. All tissue sections were examined microscopically for the evaluation of histological changes by a board certified pathologist.

[0217] Samples of the liver, spleen, kidney, and lung from all animals were collected and fixed in 2% glutaraldehyde/2% paraformaldehyde for analysis of sphingomyelin load. These tissues were post-fixed in potassium dichromate/osmium tetroxide and embedded in epon. One-micron sections were stained with tannic acid and toluidine blue for light microscopic examination. The sphingomyelin load in each sample was quantitated by computer morphometry with MetaMorph software by a board certified pathologist.

[0218] Samples of the liver, spleen, kidney, and lung from all animals were collected, frozen in liquid nitrogen, and stored frozen at $\leq -70^{\circ}\text{C}$ for possible future analysis.

Sample Analysis:

[0219] Dose analysis was measured via A280 analysis and toxicokinetic, and immunogenicity samples were analyzed by ELISA.

[0220] Ceramide analysis was measured via mass spectrometry.

[0221] Hematology and clinical pathology samples were measured using the Sysmex XTV 2000 IV Hematology Analyzer and the Radnox Daytona Clinical Chemistry Analyzer, respectively.

[0222] Tissue samples were processed and histopathological analysis was interpreted by a board certified pathologist according to SOPs. Results from the clinical pathology analysis was interpreted by a board certified pathologist according to SOPs.

8. EXAMPLE 3: ESCALATING DOSE OF RECOMBINANT HUMAN ACID SPHINGOMYELINASE (RHASM) ENZYME REPLACEMENT THERAPY

8.1. INTRODUCTION

[0223] The protocol described below utilizes within-patient dose escalation as an option for achieving higher repeat doses of rhASM. The safety, efficacy and pharmacokinetics (PK) of rhASM infusions at doses of 0.3, 0.6, and 1.0 mg/kg administered every 2 weeks (q2w) for 40 weeks, and long term safety and efficacy of rhASM infusions are evaluated.

8.2. MATERIALS AND METHODS

8.2.1. PROTOCOL DESIGN

[0224] The 12 NP-type B patients to be treated are of either gender. Patients will receive at least 1 dose of 0.1 mg/kg rhASM initially. Patients that tolerate the 0.1 mg/kg rhASM infusion are then administered escalating doses of 0.3 mg/kg, 0.6 mg/kg, and 1 mg/kg every 2 weeks, as tolerated. Patients who tolerate 1.0 mg/kg are then stratified by spleen volume (<12 times or ≥ 12 times multiples of normal) and randomized to receive one of 2 target doses: 1.0 mg/kg rhASM or 3.0 mg/kg; patients randomized to the 3.0 mg/kg group will escalate to 2.0 mg/kg and then 3.0 mg/kg, as tolerated. Patients who do not tolerate the 0.1 mg/kg dose of rhASM are replaced. Patients who cannot tolerate escalation at higher doses will remain at their maximum tolerated dose for the duration of the 26 week maintenance dose period.

[0225] All patients will have doses escalated from 0.1 mg/kg to their target dose. Dosage adjustments during the escalation period will occur at every 2 week intervals until the target dose is reached (if tolerated). Following the initial infusion (0.1 mg/kg rhASM) as well as subsequent doses, patient outcomes, i.e., adverse event (AE) occurrence / severity and serum bilirubin, hsCRP, and other acute phase response proteins, and ceramide, will be reviewed. The following criteria will determine the next dose to be administered during the dose escalation period:

1. Total bilirubin value ≤ 2.0 mg/dL or mild AE → escalate to next dose (if applicable)
2. Total bilirubin value = 2.1 - 3.0 mg/dL or moderate AE → no dosage escalation; repeat current dose,
3. Total bilirubin value >3.0 mg/dL) or severe AE → decrease dose to previously administered/tolerated.

[0226] Any serious adverse event (SAE) judged to be related to rhASM, a bilirubin value that does not decrease to <2.0 mg/dL prior to the next scheduled dose or any AE that raises concern regarding the safety of rhASM at the administered dose may be considered a dose-limiting-toxicity (DLT). If a patient experiences a DLT, subsequent doses for the patient should be temporarily halted. Patients may be re-challenged to receive the dose that resulted in a DLT and if tolerated, treatment will proceed as originally planned.

[0227] If a patient cannot tolerate 2 doses of 0.1 mg/kg (i.e., initial infusion and one re-challenge dose) they will not be treated with escalating doses and will be discontinued and replaced in the study. Patients who tolerate the 0.3 mg/kg dose will receive the initial rhASM infusion (0.1 mg/kg) and, after 2 weeks, 0.3 mg/kg rhASM (provided the dose escalation criteria are met following the 0.1 mg/kg dose). Subsequent rhASM doses will be administered during the dose escalation period q2w for a maximum of 18 weeks. If a patient successfully escalates to 0.3 mg/kg and subsequently meets criteria #2 or #3 (above), the patient may be re challenged twice. If re-challenge is unsuccessful (i.e., target dose cannot be reached), the patient will

continue on a rhASM dose of 0.1 mg/kg for the remainder of the 40-week treatment period.

[0228] Patients to be treated with the 0.6 mg/kg dose regimen will receive the initial rhASM infusion (0.1 mg/kg), followed by 1 dose of 0.3 mg/kg rhASM, followed by 0.6 mg/kg rhASM q2w for the remainder of the 40-week treatment period (provided the previous rhASM infusions of 0.1 mg/kg and 0.3 mg/kg are well tolerated). Patients to be treated with the 1.0 mg/kg regimen will receive the initial rhASM infusion (0.1 mg/kg), followed by 1 dose of 0.3 mg/kg rhASM, followed by 1 dose of 0.6 mg/kg rhASM, followed by 1.0 mg/kg rhASM q2w for the remainder of the 40-week treatment period (provided the previous rhASM infusions of 0.1 mg/kg, 0.3 mg/kg, and 0.6 mg/kg are well tolerated). If a patient successfully escalates from 0.3 to 0.6 mg/kg or from 0.6 to 1.0 mg/kg and subsequently meets criteria #2 or #3 (above), the patient may be re-challenged twice. If re-challenge is unsuccessful (i.e., target dose cannot be reached), the patient will continue on the lower tolerated dose for the remainder of the 40-week treatment period.

[0229] Following the 40-week treatment phase, patients may be allowed to continue their treatment at their maintenance dose level.

8.2.2. PATIENTS

[0230] Each patient should meet the following inclusion criteria to be treated in accordance with these regimens:

1. Documented ASM deficiency consistent with Niemann-Pick (N-P) disease;
2. Diffusing capacity (DLCO) >20% and ≤80% of the predicted normal value;
3. Spleen volume ≥8 times normal (≥1.6% of body weight);
4. Female patients of childbearing potential must have a serum pregnancy test negative for β-hCG, and agree to use a medically acceptable method of birth control for the duration of the protocol.

8.2.3. TREATMENT

[0231] Patients will receive a single 0.1 mg/kg rhASM IV over an approximate 35 minute time period. Administration guidelines are summarized in Table 8, below. Patients that tolerate the initial 0.1 mg/kg rhASM infusion will be dose escalated to a target treatment dose (rhASM 0.3, 0.6 or 1.0 mg/kg). All patients will have doses escalated from 0.1 mg/kg to their target dose. Dosage adjustments during the escalation period will occur at every 2 week intervals until the target dose is reached.

Table 8: Administration of rhASM

Target Dose (mg/kg)	Approximate Infusion Rate (mL/hr)	Approximate Infusion Rate (mg/kg/hr)	Length of Administration (approx. time in minutes)
0.1	Step 1: 20 mL/hr over 20 min (+/- 5 min), if no IAR	Step 1: 0.1 mg/kg/hr over 20 min (+/- 5 min), if no IAR	35
	Step 2: 60 mL/hr for the remainder of the infusion if no IAR	Step 2: 0.3 mg/kg/hr for the remainder of the infusion if no IAR	
0.3	Step 1: 17 mL/hr over 20 min (+/- 5 min), if no IAR	Step 1: 0.1 mg/kg/hr over 20 min (+/- 5 min), if no IAR	60
	Step 2: 50 mL/hr over 20 min (+/- 5 min), if no IAR	Step 2: 0.3 mg/kg/hr over 20 min (+/- 5 min), if no IAR	
	Step 3: 100 mL/hr for the remainder of the infusion if no IAR	Step 3: 0.6 mg/kg/hr for the remainder of the infusion if no IAR	
0.6	Step 1: 17 mL/hr over 20 min (+/- 5 min), if no IAR	Step 1: 0.1 mg/kg/hr over 20 min (+/- 5 min), if no IAR	80
	Step 2: 50 mL/hr over 20 min (+/- 5 min), if no IAR	Step 2: 0.3 mg/kg/hr over 20 min (+/- 5 min), if no IAR	
	Step 3: 100 mL/hr over 20 min (+/- 5 min), if no IAR	Step 3: 0.6 mg/kg/hr over 20 min (+/- 5 min), if no IAR	
	Step 4: 167 mL/hr for the remainder of the infusion if no IAR	Step 4: 1.0 mg/kg/hr for the remainder of the Infusion if no IAR	
1.0	Step 1: 10 mL/hr over 20 min (+/- 5 min), if no IAR	Step 1: 0.1 mg/kg/hr over 20 min (+/- 5 min), if no IAR	100
	Step 2: 30 mL/hr over 20 min (+/- 5 min), if no IAR	Step 2: 0.3 mg/kg/hr over 20 min (+/- 5 min), if no IAR	
	Step 3: 60 mL/hr over 20 min (+/- 5 min), if no IAR	Step 3: 0.6 mg/kg/hr over 20 min (+/- 5 min), if no IAR	
	Step 4: 100 mL/hr for the remainder of the infusion if no IAR	Step 4: 1.0 mg/kg/hr for the remainder of the infusion if no IAR	

[0232] Each patient's degree of splenomegaly at baseline can be recorded in multiples of normal (x normal) as an indicator of disease severity. Normal spleen volume is equal to 0.2% of body weight.

[0233] At each visit, patients should be evaluated for new or ongoing adverse events (AEs).

[0234] Clinical endpoints can be measured as the % change from baseline to Week 26 of the maintenance dose period. The primary efficacy endpoint is a decrease in spleen volume as measured by MRI. Secondary efficacy endpoints include a decrease in liver sphingomyelin level; an increase in exercise capacity as determined by % predicted maximum workload by cycle ergometry; increased pulmonary function as a % predicted DLco; increased lung clearance which can be determined by bronchial alveolar lavage (BAL) cell count and profile, sphingomyelin, ceramide, cytokine and chitotriosidase levels. Tertiary efficacy endpoints can include a decrease in liver volume as measured by MRI; increased pulmonary function which can be determined by % predicted FVC, FEV1, TLC; improved lung appearance determined by high resolution CT scan, chest X-ray; improved lipid profile as determined by HDL, LDL, total cholesterol, triglyceride levels, and total cholesterol: HDL cholesterol ratio; improved platelet count; hemoglobin; decreased sphingomyelin levels in skin, plasma, DBS; and improvement in other biomarkers such as CCL18, ACE.

9. EXAMPLE 4: ESCALATING DOSE OF RECOMBINANT HUMAN ACID SPHINGOMYELINASE (RHASM) ENZYME REPLACEMENT THERAPY

9.1. INTRODUCTION

[0235] The protocol described below utilizes a repeat-dose, dose comparison to evaluate the safety, efficacy and pharmacokinetics of recombinant human acid sphingomyelinase (rhASM) in adult patients with ASMD. The objectives of the protocol include: (i) the evaluation of the safety of dose escalation of rhASM; (ii) the evaluation of the safety, efficacy and pharmacokinetics of the maximum tolerated or randomized dose of rhASM administered intravenously every 2 weeks for 26 weeks; and (iii) the evaluation of the long-term safety and efficacy of rhASM infusions administered intravenously every 2 weeks from week 26 until protocol completion (at least 182 weeks in duration).

9.2. MATERIALS AND METHODS

9.2.1. PATIENTS

[0236] Each patient should meet the following inclusion criteria to be treated in accordance with

these regimens:

1. Documented acid sphingomyelinase (ASM) deficiency consistent with Niemann-Pick disease (NPD).
2. Two or more characteristic clinical features, including thrombocytopenia, anemia, neutropenia, hepatomegaly, splenomegaly, and pulmonary disease consistent with non-neuronopathic NPD.
3. Diffusing capacity of carbon monoxide (DLco) > 20% and ≤ 80% of the predicted normal value;
4. Spleen volume ≥ 8 multiples of normal (MN) (i.e., $\geq 1.6\%$ of body weight). A partial splenectomy can be permitted if performed ≥ 1 year from Screening/Baseline and residual spleen volume is ≥ 8 MN.
5. Female patients of childbearing potential must have a negative serum pregnancy test for β -human chorionic gonadotropin (β -HCG) and agree to use a medically accepted method of contraception for the duration of the protocol.

9.2.2. PROTOCOL DESIGN

[0237] Patients who can tolerate rhASM at 0.1 mg/kg can be enrolled in the protocol. For each patient, protocol participation can consist of 3 periods:

1. Screening/Baseline (-60 to -1 days).
2. Primary Treatment Period (approximately 32 to 46 weeks).

Dose Escalation (DE) Phase (Primary DE - approximately 6 to 16 weeks).

- Upon safely escalating from 0.1 to 0.3 to 0.6 to 1.0 mg/kg rhASM, patients can be stratified by spleen volume (< 12 and ≥ 12 MN) and randomized to either continue dosing at 1.0 mg/kg or continue dose escalation through 2.0 and 3.0 mg/kg and then receive 3.0 mg/kg rhASM or the maximum tolerated dose (Secondary DE - 4 weeks) for the remainder of the protocol.
- Non-randomized patients can remain at their maximum tolerated dose (< 1.0 mg/kg rhASM).

Dose Maintenance (DM) Phase (26 weeks at maximum tolerated or randomized dose).

3. Long-term Treatment Period (at least 182 weeks at maximum tolerated or randomized dose)

[0238] The Screening/Baseline assessments can be completed at least 24 hrs prior to the initial infusion of rhASM. Enrollment into the protocol is contingent upon the patient being able to tolerate 2 doses of rhASM at 0.1 mg/kg. Initially, all eligible patients can receive a single dose of

0.1 mg/kg rhASM on dose escalation (DE) Day 1. Patients who are unable to tolerate this dose are re-challenged 2 weeks later. Patients who cannot tolerate 2 doses of 0.1 mg/kg rhASM (i.e., initial dose and re-challenge dose) are discontinued and replaced, to ensure that approximately 12 patients (who can tolerate rhASM at 0.1 mg/kg) are enrolled.

[0239] Doses of rhASM can be escalated every 2 weeks from 0.1 to 0.3 to 0.6 to 1.0 mg/kg during the Primary DE Phase. During the Primary DE Phase, patients can have rhASM doses safely escalated every 2 weeks from 0.1 to 1.0 mg/kg (as indicated in Figure 7).

[0240] During the Primary and Secondary DE Phases, the following dose escalation criteria can determine the next dose of rhASM to be administered:

1. 1.If total bilirubin (the highest value prior to the next scheduled dose of rhASM and includes the pre infusion blood draw) is ≤ 2.0 mg/dL or no/mild related adverse event (AE) → Escalate to next dose.
2. 2.If total bilirubin is > 2.0 but < 3.0 mg/dL or moderate related AE → Repeat same dose.
 - If total bilirubin remains > 2.0 mg/dL just prior to next dose → Stop further dosing of patient temporarily (potential dose-limiting toxicity [DLT]).
3. 3.If total bilirubin is ≥ 3.0 mg/dL or severe related AE → Decrease dose.
 - If total bilirubin remains > 2.0 mg/dL just prior to next dose → Stop further dosing of patient temporarily (potential DLT).
4. 4. Patients can be re-challenged (at a particular dose level) as many times as needed in the Primary DE Phase only (re-challenge is not permitted in the Secondary DE Phase), before being randomized or staying on their maximum tolerated dose by the end of the 16-week Primary DE Phase.
5. 5. Enrolled patients (i.e., those who can tolerate rhASM at 0.1 mg/kg) can not be replaced if they cannot escalate up to a dose of 1.0 mg/kg and be randomized, or cannot tolerate their target randomization dose (i.e., 1.0 or 3.0 mg/kg rhASM). These patients can continue in the protocol at their maximum tolerated dose.

[0241] If an infusion is missed, the patient can receive the same dose as the previous infusion. If the visit window of ± 5 days is exceeded, that infusion can not be done and the patient should have his/her next infusion at the scheduled time for that infusion.

[0242] For the purpose of this protocol, if any of the following criteria are met, the results can be considered indicative of potential dose limiting toxicity (DLT) for rhASM at a given dose:

- Any serious adverse event (SAE) judged by the physician to be related to rhASM, or
- Total bilirubin remains > 2.0 mg/dL just prior to next dose, or
- Any adverse event (AE) that, in the opinion of the physician, raises concern regarding the safety of rhASM at the administered dose.

[0243] The severity of a related adverse event will be assessed by a physician. A mild related adverse event is usually transient and may require only minimal treatment or therapeutic intervention. A moderate related adverse event is usually alleviated with additional specific therapeutic intervention. This event interferes with usual activities of daily living, causing discomfort, but poses no significant or permanent risk of harm to the subject. A severe adverse event interrupts usual activities of daily living, or significantly affects clinical status, or may require intensive therapeutic intervention.

[0244] All patients who had doses escalated and safely tolerate 1.0 mg/kg rhASM by Week 16 can be stratified by spleen volume (< 12 and ≥ 12 MN) and randomized in a 1:1 ratio to either:

- Continue receiving 1.0 mg/kg rhASM (or maximum tolerated dose) every 2 weeks for 26 weeks or
- Continue dose escalation (DE) through 2.0 and 3.0 mg/kg and then receive 3.0 mg/kg rhASM (or maximum tolerated dose) every 2 weeks for 26 weeks.

[0245] During the Secondary DE Phase, patients randomized to the 3.0 mg/kg group can have only 4 weeks to escalate their rhASM dose to 3.0 mg/kg before starting the 26-week DM Phase at 3.0 mg/kg (or maximum tolerated dose; see Figure 7).

[0246] The Primary DE Phase can range from approximately 6 to 16 weeks in duration for each patient. This can depend on individual patient tolerability issues, if any, encountered by the patient during dose escalation of rhASM. During the Primary DE Phase, each patient can have their dose of rhASM escalated every 2 weeks from 0.1 to 1.0 mg/kg (as indicated in Figure 7).

[0247] The Primary DE Phase can be completed when a patient receives and tolerates a dose of 1.0 mg/kg rhASM or reaches Week 16, whichever occurs first. If no criteria leading to a dose re-challenge or a decrease in dose are met, a patient can receive a single infusion of each dose (i.e., a total of 4 infusions of rhASM), resulting in a Primary DE Phase of 6 weeks. However, if criteria leading to dose re-challenge or decrease in dose are met the duration of the Primary DE Phase can be longer than 6 weeks, but will not exceed 16 weeks.

[0248] Patients who had doses escalated and safely tolerate 1.0 mg/kg by Week 16 can be assigned to 1 of 2 target dose groups (i.e., 1.0 or 3.0 mg/kg rhASM).

[0249] Patients randomized to 3.0 mg/kg rhASM can enter the Secondary DE Phase (see Figure 7), consisting of 2 infusions: the first infusion (i.e., 2.0 mg/kg) being 2 weeks after the first tolerated dose of 1.0 mg/kg, and the second infusion (i.e., 3.0 mg/kg or maximum tolerated dose) being 4 weeks after the first tolerated dose of 1.0 mg/kg. Therefore the Secondary DE Phase can be completed 4 weeks after the first tolerated dose of 1.0 mg/kg. No re-challenge dose will be allowed. If the patient cannot tolerate the first dose at 2.0 mg/kg, the second rhASM dose can be decreased to the maximum tolerated dose (i.e., 1.0 mg/kg) or temporarily halted in the event of a potential dose limiting toxicity (DLT).

[0250] Patients can continue receiving rhASM at the maximum tolerated or randomized dose administered IV every 2 weeks during the 26-week DM Phase of the Primary Treatment Period. This can include both randomized and non-randomized patients.

[0251] As indicated in Figure 7, patients in the 1.0 mg/kg dose group can start the DM Phase at their first dose of 1.0 mg/kg following randomization, whereas patients in the 3.0 mg/kg group can start the DM Phase at their third dose of rhASM following randomization. Subsequent rhASM doses can be administered IV every 2 weeks for 26 weeks in the DM Phase for all randomized patients.

[0252] Non-randomized patients can start the DM Phase at their first dose of rhASM 2 weeks after their 16-week DE Phase. These patients can continue on their maximum tolerated dose of rhASM (< 1.0 mg/kg) every 2 weeks for a total of 26 weeks.

[0253] If a randomized patient experiences a moderate/severe related AE (i.e., an infusion associated reaction (IAR)) during the infusion in the DM Phase, the patient may have the rhASM infusion stopped and restarted (i.e., interrupted) or the infusion rate slowed down. Provided that a potential DLT has not occurred, the patient can continue on this dose of rhASM for the remainder of the DM Phase.

[0254] After all Week 26 protocol assessments have been completed, all patients (including non-randomized patients) can enter the Long-Term Treatment period and continue rhASM treatment (at the rhASM dose that was administered during the DM Phase) IV every 2 weeks for at least 182 weeks [3.5 years] in duration or until termination of the protocol. The Long-Term Treatment Period includes the Protocol Completion (or patient withdrawal/discontinuation) visit and a safety follow-up phone call (30 to 37 days after the last dose of rhASM). Individual patient doses of rhASM may be adjusted in the Long-Term Treatment Period based on the results of the Primary Treatment Period analyses. Any required dose escalation can occur as previously described.

9.3. TREATMENT

[0255] Patients will receive intravenous infusions of rhASM at 0.1, 0.3, 0.6 and 1.0 mg/kg every 2 weeks during the Primary DE Phase. Patients randomized to 3.0 mg/kg rhASM will receive 2.0 mg/kg prior to receiving 3.0 mg/kg (or maximum tolerated dose) 2 weeks later during the Secondary DE Phase. During the 26-week DM Phase, patients will be administered 1.0 or 3.0 mg/kg (or maximum tolerated dose) rhASM every 2 weeks following the DE Phase. During the Long-Term Treatment Period, the rhASM dose that was administered during the DM Phase will be administered IV every 2 weeks.

[0256] Patients will receive each intravenous infusion of rhASM over a period of approximately 35 to 135 minutes (min) depending on the dose (see Table 9 below). Protocol treatment (rhASM) will be infused using a standard programmable infusion pump and a 0.22 micron, low

protein-binding, in-line filter. To calculate the dose in mg/kg, use actual weight for patients with body mass index (BMI) ≤ 30 (weight in kg)/(height in meters); for patients with BMI > 30 , calculate the weight corresponding to a BMI of 30 using the patient's height.

TABLE 9: Administration of rhASM

rhASM Dose (mg/kg)	Total Volume of 0.9% Sodium Chloride for Injection, to be mixed (mL)	Approximate Infusion Rate (mL/hr)	Approximate Infusion Rate (mg/kg/hr)	Length of Administration (approximate time [min])
0.1	20	Step 1: 20 mL/hr over 20 min (± 5 min), if no IAR	Step 1: 0.1 mg/kg/hr over 20 min (± 5 min), if no IAR	35
		Step 2: 60 mL/hr for the remainder of the infusion if no IAR	Step 2: 0.3 mg/kg/hr for the remainder of the infusion if no IAR	
0.3	50	Step 1: 17 mL/hr over 20 min (± 5 min), if no IAR	Step 1: 0.1 mg/kg/hr over 20 min (± 5 min), if no IAR	60
		Step 2: 50 mL/hr over 20 min (± 5 min), if no IAR	Step 2: 0.3 mg/kg/hr over 20 min (± 5 min), if no IAR	
		Step 3: 100 mL/hr for the remainder of the infusion if no IAR	Step 3: 0.6 mg/kg/hr for the remainder of the infusion if no IAR	
0.6	100	Step 1: 17 mL/hr over 20 min (± 5 min), if no IAR	Step 1: 0.1 mg/kg/hr over 20 min (± 5 min), if no IAR	80
		Step 2: 50 mL/hr over 20 min (± 5 min), if no IAR	Step 2: 0.3 mg/kg/hr over 20 min (± 5 min), if no IAR	
		Step 3: 100 mL/hr over 20 min (± 5 min), if no IAR	Step 3: 0.6 mg/kg/hr over 20 min (± 5 min), if no IAR	
		Step 4: 167 mL/hr for the remainder of the infusion if no IAR	Step 4: 1.0 mg/kg/hr for the remainder of the infusion if no IAR	
1.0	100	Step 1: 10 mL/hr over 20 min (± 5 min)	Step 1: 0.1 mg/kg/hr over 20 min	100

rhASM Dose (mg/kg)	Total Volume of 0.9% Sodium Chloride for Injection, to be mixed (mL)	Approximate Infusion Rate (mL/hr)	Approximate Infusion Rate (mg/kg/hr)	Length of Administration (approximate time [min])
		min), if no IAR	min (± 5 min), if no IAR	
		Step 2: 30 mL/hr over 20 min (± 5 min), if no IAR	Step 2: 0.3 mg/kg/hr over 20 min (± 5 min), if no IAR	
		Step 3: 60 mL/hr over 20 min (± 5 min), if no IAR	Step 3: 0.6 mg/kg/hr over 20 min (± 5 min), if no IAR	
		Step 4: 100 mL/hr for the remainder of the infusion if no IAR	Step 4: 1.0 mg/kg/hr for the remainder of the infusion if no IAR	
2.0	200	Step 1: 10 mL/hr over 20 min (± 5 min), if no IAR	Step 1: 0.1 mg/kg/hr over 20 min (± 5 min), if no IAR	120
		Step 2: 30 mL/hr over 20 min (± 5 min), if no IAR	Step 2: 0.3 mg/kg/hr over 20 min (± 5 min), if no IAR	
		Step 3: 60 mL/hr over 20 min (± 5 min), if no IAR	Step 3: 0.6 mg/kg/hr over 20 min (± 5 min), if no IAR	
		Step 4: 100 mL/hr over 20 min (± 5 min), if no IAR	Step 4: 1.0 mg/kg/hr over 20 min (± 5 min), if no IAR	
		Step 5: 200 mL/hr for the remainder of the infusion if no IAR	Step 5: 2.0 mg/kg/hr for the remainder of the infusion if no IAR	
3.0	300	Step 1: 10 mL/hr over 20 min (± 5 min), if no IAR	Step 1: 0.1 mg/kg/hr over 20 min (± 5 min), if no IAR	135
		Step 2: 30 mL/hr over 20 min (± 5 min), if no IAR	Step 2: 0.3 mg/kg/hr over 20 min (± 5 min), if no IAR	

rhASM Dose (mg/kg)	Total Volume of 0.9% Sodium Chloride for Injection, to be mixed (mL)	Approximate Infusion Rate (mL/hr)	Approximate Infusion Rate (mg/kg/hr)	Length of Administration (approximate time [min])
		Step 3: 60 mL/hr over 20 min (\pm 5 min), if no IAR	Step 3: 0.6 mg/kg/hr over 20 min (\pm 5 min), if no IAR	
		Step 4: 100 mL/hr over 20 min (\pm 5 min), if no IAR	Step 4: 1.0 mg/kg/hr over 20 min (\pm 5 min), if no IAR	
		Step 5: 200 mL/hr over 20 min (\pm 5 min), if no IAR	Step 5: 2.0 mg/kg/hr over 20 min (\pm 5 min), if no IAR	
		Step 6: 300 mL/hr for the remainder of the infusion if no IAR	Step 6: 3.0 mg/kg/hr for the remainder of the infusion if no IAR	
hr = hour; IAR = Infusion-associated reaction; min = minutes				

[0257] Clinical end points can be measured as the percent (%) change from baseline in spleen volume multiples of normal (as measured by magnetic resonance imaging) after 26 weeks of receiving the maximum tolerated or randomized dose of rhASM. Secondary efficacy endpoints include liver volume (as measured by MRI); pulmonary imaging (by high resolution computed tomography scan and chest X ray; pulmonary function tests, including percent predicted diffusing capacity of carbon monoxide, percent predicted forced vital capacity, forced expiratory volume in 1 second, and total lung capacity; exercise capacity by cycle ergometry, including percent predicted maximum workload, peak oxygen consumption, and carbon dioxide production; physician global assessment of change; efficacy biomarkers such as serum chitotriosidase, CCL18, and ACE; and hematology parameters such as platelet count, hemoglobin level. Efficacy assessments can also include fasting lipids, coagulation studies, disease related biomarkers, health outcome measures, and patient photographs.

[0258] Safety assessments can be performed prior to, during and/or subsequent to dose administration. Safety assessments that can be performed include: a physical examination with neurological assessment, vital signs (e.g., systolic and diastolic blood pressure, temperature, heart rate, respiratory rate and oxygen saturation), ECG, CHO with Doppler, blood chemistry (e.g., sodium, potassium, calcium, chloride, blood urea nitrogen, creatinine, uric acid, ALT, aspartate aminotransferase, total bilirubin, lactate dehydrogenase, alkaline phosphate, total protein, albumin, glucose, cholesterol, etc.), hematology (e.g., a complete blood count), urinalysis, biomarker analysis for biomarkers related to cancer, hormones, cytokines (e.g., IL-8

and IL-6), cardiovascular risk, acute phase reactants and other cellular processes, serum anti-rhASM IgG concentration, serum anti-rhASM IgE concentration, serum tryptase activity, and skin testing for hypersensitivity. Further, pharmacokinetics and pharmacodynamics assessments can be performed prior to, during and/or subsequent to dose administration. For example, sphingomyelin levels can be assessed in the liver and skin by biopsy, and in plasma and DBS by tandem mass spectrometry.

[0259] The invention is not to be limited in scope by the specific embodiments described herein.

REFERENCES CITED IN THE DESCRIPTION

Cited references

This list of references cited by the applicant is for the reader's convenience only. It does not form part of the European patent document. Even though great care has been taken in compiling the references, errors or omissions cannot be excluded and the EPO disclaims all liability in this regard.

Patent documents cited in the description

- [WO2007084737A2](#) [0005]
- [US20090130079](#) [0105]
- [US20090123451A](#) [0105]
- [US4039388A](#) [0112] [0137]
- [US4082781A](#) [0112] [0137]
- [US5686240A](#) [0112] [0122] [0137]
- [US7563591B](#) [0112] [0137]
- [WO2007078806A](#) [0112] [0137]
- [WO2006058385A](#) [0112] [0137]
- [US6541218B](#) [0114] [0114] [0122] [0124]
- [US7527956B](#) [0117] [0118] [0122]
- [WO2008136451A](#) [0117]
- [US7001994B](#) [0118] [0131]
- [WO2010075010A](#) [0118] [0131]
- [US20100173385](#) [0118] [0131]
- [US20090029467](#) [0119]
- [US7560424B](#) [0119]
- [US7396811B](#) [0119]
- [WO2007091250A](#) [0119]

- [US20100183577 \[0119\]](#)
- [US20040101904 \[0119\]](#)
- [US20020150981 \[0121\]](#)
- [US5773278A \[0122\] \[0122\]](#)
- [US5641670A \[0122\] \[0125\]](#)
- [US5047335A \[0124\]](#)
- [US5929304A \[0127\]](#)
- [US7504560B \[0127\]](#)
- [US6770799B \[0127\]](#)
- [US6551820B \[0127\]](#)
- [US6136320A \[0127\]](#)
- [US6034298A \[0127\]](#)
- [US5914935A \[0127\]](#)
- [US5612487A \[0127\]](#)
- [US5484719A \[0127\]](#)
- [US20090208477 \[0127\]](#)
- [US20090082548A \[0127\]](#)
- [US20090053762A \[0127\]](#)
- [US20080038232A \[0127\] \[0127\]](#)
- [US20070275014A \[0127\]](#)
- [US20060204487A \[0127\] \[0127\]](#)
- [US20090208477A \[0127\]](#)
- [WO0215927A \[0128\] \[0129\]](#)
- [US7138262B \[0128\] \[0129\]](#)
- [US5549892A \[0130\]](#)
- [US5716614A \[0134\]](#)
- [US7750050B \[0177\]](#)
- [WO2004045574A \[0177\]](#)
- [WO2010015816A \[0177\]](#)
- [US7658916B \[0178\]](#)

Non-patent literature cited in the description

- **GOODMAN** Genetic Disorders Among The Jewish People John Hopkins Univ. Press 1979 000096-100 [\[0004\]](#)
- **MIEKLE et al.** JAMA, 1999, vol. 281, 3249-254 [\[0004\]](#)
- **POORTHUIS et al.** Hum Genet, 1999, vol. 105, 151-156 [\[0004\]](#)
- **PINTO et al.** Euro. J. Hum. Gene, 2004, vol. 12, 87-92 [\[0004\]](#)
- **DODGE et al.** Exp. Neurol., 2009, vol. 215, 2349-57 [\[0005\]](#)
- **ZIEGLER et al.** Mol. Genet. Metab., 2009, vol. 97, 135-42 [\[0005\]](#)
- **MIRANDA et al.** FASEB J., 2000, vol. 14, 131988-95 [\[0005\]](#)

- **SIMONARO et al.**Am. J. Hum. Genet., 2002, vol. 71, 61413-9 [\[0005\]](#)
- **MIRANDA et al.**FASEB, 2000, vol. 14, 1988- [\[0019\]](#) [\[0062\]](#) [\[0186\]](#)
- **HE et al.**Biochimica et Biophysica Acta, 1999, vol. 1432, 251-264 [\[0019\]](#)
- **C. NICKERSON. J. MURRAYA. VITSKYM. HAWESS. RYANP. EWINGB. THURBERGL. ANDREWS**Dose Responsive Toxicological Findings Following Intravenous Administration of Recombinant Human Acid Sphingomyelinase (rhASM) to Acid Sphingomyelinase Knock-out (ASMKO) MiceAmerican Society of Human Genetics20050000 [\[0019\]](#) [\[0062\]](#)
- **J. MURRAYA.M. D'ANGONAC. NICKERSONA. VITSKYM. HAWESS. RYANP. EWINGB. THURBERGL. ANDREWS**Elevations of Pro-Inflammatory Cytokines and Decreases in Cardiovascular Hemodynamics Following Intravenous Administration of Recombinant Human Acid Sphingomyelinase (rhASM) to Acid Sphingomyelinase Knock-out (ASMKO) MiceSociety of Toxicology20060000 [\[0019\]](#) [\[0062\]](#)
- Am. Rev. Respir. Dis.American Thoracic Society19910000vol. 144, 1202-1218 [\[0036\]](#) [\[0048\]](#)
- **HE et al.**Biochimica et Biophysica Acta, 1999, vol. 1432, 251-264 [\[0061\]](#) [\[0124\]](#) [\[0132\]](#)
- **MILAUŠ et al.**FEBS Letters, 2010, vol. 584, 1887-1894 [\[0064\]](#)
- **SMITHSCHUCHMAN**FASEB, 2008, vol. 22, 3419-3431 [\[0064\]](#)
- **SCHISSEL et al.**J. Biol. Chem., 1998, vol. 273, 2738-2746 [\[0065\]](#)
- **HE et al.**Analytical Biochemistry, 2003, vol. 314, 116-120 [\[0071\]](#) [\[0071\]](#) [\[0112\]](#) [\[0112\]](#) [\[0113\]](#) [\[0113\]](#) [\[0116\]](#) [\[0116\]](#) [\[0117\]](#) [\[0117\]](#) [\[0117\]](#) [\[0137\]](#)
- **HORINOUCI et al.**Nature Genetics, 1995, vol. 10, 288-293 [\[0071\]](#) [\[0071\]](#)
- **DODGE et al.**Experimental Neurology, 2009, vol. 215, 349-357 [\[0105\]](#)
- **YANG et al.**Experimental Neurology, 2007, vol. 207, 258-266 [\[0105\]](#)
- **ZIEGLER et al.**Molecular Genetics and Metabolism, 2009, vol. 97, 35-42 [\[0106\]](#)
- **MENDOZA et al.**Cancer, 1999, vol. 85, 51186-1196 [\[0111\]](#)
- **CLEELAND et al.**Ann Acad Med Singapore, 1994, vol. 23, 2129-138 [\[0111\]](#)
- **SCHUNEMANN et al.**Eur. Respir. J., 2005, vol. 25, 31-40 [\[0111\]](#)
- **SCHUCHMAN et al.**J. Biol. Chem., 1991, vol. 266, 8531-8539 [\[0114\]](#)
- **WANSCHUCHMAN**Biochimica et Biophysica Acta, 1995, vol. 1270, 207-210 [\[0116\]](#)
- **SCHUCHMAN et al.**J. of Biol. Chem, 1991, vol. 266, 8531-8539 [\[0116\]](#)
- **SCHUCHMAN et al.**Nucleic Acids Research, 1991, vol. 19, 113160- [\[0116\]](#)
- **GAMACHO et al.**J. Pharmacol. Exp. Ther., 2008, vol. 325, 400-408 [\[0117\]](#)
- **HE et al.**Biochimica et Biophysica Acta, 1999, vol. 1432, 251-264 [\[0117\]](#)
- **DHAMI et al.**Lab. Invest., 2001, vol. 81, 987-999 [\[0117\]](#)
- **QIU et al.**J. Biol. Chem., 2003, vol. 278, 3532744-32752 [\[0118\]](#)
- **SCHISSEL et al.**J. Biol. Chem, 1998, vol. 273, 18250-18259 [\[0118\]](#)
- **SCHUCHMAN et al.**J. Biol. Chem, 1991, vol. 266, 8531-8539 [\[0122\]](#)
- **SHOJI et al.**Vaccine, 2008, vol. 26, 232930-2934 [\[0127\]](#)
- **D'AOUST et al.**J. Plant Biotechnology, 2008, vol. 6, 9930-940 [\[0127\]](#)
- **RASALA et al.**Plant Biotechnology Journal, 2010, [\[0127\]](#)
- **MATSUOKA et al.**Mole. Ther., 2010, vol. 18, 1519-1526 [\[0131\]](#)
- **AKEBOSHI et al.**Glycobiology, 2009, vol. 19, 91002-1009 [\[0131\]](#)
- **MURO et al.**Mol. Ther., 2006, vol. 13, 1135-141 [\[0134\]](#)
- **SIMONARO et al.**Am. J. Hum. Genet., 2002, vol. 71, 1413-1419 [\[0136\]](#)
- Am Rev Respir DisATS19910000vol. 144, 1202-1218 [\[0154\]](#)

- **KAMARCH** Methods Enzymol, 1987, vol. 151, 150-165 [\[0166\]](#)
- **LI et al.** Biochim Biophys Act, 2007, vol. 1771, 91186-1194 [\[0179\]](#)
- **BUCCINNA et al.** J. Neurochem., 2009, vol. 109, 105-115 [\[0186\]](#)

Patentkrav

- 1.** Rekombinant human sur sphingomyelinase (rhASM) til anvendelse i en fremgangsmåde til behandling af en mangel på sur sphingomyelinase (ASMD) hos et menneskeligt individ med behov derfor, hvilken fremgangsmåde omfatter følgende trin i følgende rækkefølge:
- a. indgivelse til det menneskelige individ af mindst en indledende dosis på 0,025 mg/kg til 0,05 mg/kg af nævnte rhASM; og
 - b. indgivelse til det menneskelige individ af en dosisoptrappingsplan i følgende doser: (i) 0,1 mg/kg af nævnte rhASM, (ii) 0,3 mg/kg af nævnte rhASM, og (iii) 0,6 mg/kg af nævnte rhASM, hvor hver dosis indgives mindst en gang, før dosen optrappes til det næste niveau, og hvor hver dosis indgives to uger efter indgivelsen af den forudgående dosis.
- 2.** rhASM til anvendelse ifølge krav 1, hvor dosen på 0,1 mg/kg indgives en gang før optrapning af dosen til det næste niveau.
- 3.** rhASM til anvendelse ifølge krav 1 eller 2, hvor dosen på 0,3 mg/kg indgives to gange før optrapning af dosen til det næste niveau.
- 4.** rhASM til anvendelse ifølge et hvilket som helst af kravene 1 til 3, hvor dosen på 0,6 mg/kg indgives to gange før optrapning af dosen til det nævnte niveau.
- 5.** rhASM til anvendelse ifølge et hvilket som helst af kravene 1 til 4, hvor fremgangsmåden yderligere omfatter følgende dosis: (iv) 1 mg/kg af nævnte rhASM.
- 6.** rhASM til anvendelse ifølge krav 5, hvor fremgangsmåden yderligere omfatter følgende dosis: (v) 2 mg/kg af nævnte rhASM.
- 7.** rhASM til anvendelse ifølge krav 6, hvor fremgangsmåden yderligere omfatter følgende dosis: (vi) 3 mg/kg af nævnte rhASM.
- 8.** rhASM til anvendelse ifølge et hvilket som helst af kravene 1 til 7, hvor fremgangsmåden yderligere omfatter indgivelse af en vedligeholdelsesdosis af

nævnte rhASM til det menneskelige individ.

9. rhASM til anvendelse ifølge krav 8, hvor vedligeholdelsesdosen indgives hver anden uge.

5

10. rhASM til anvendelse ifølge krav 8 eller 9, hvor vedligeholdelsesdosen er

- a) den højeste tolererede dosis;
- b) 1 mg/kg til 3 mg/kg af nævnte rhASM; eller
- c) 3 mg/kg af nævnte rhASM.

10

11. rhASM til anvendelse ifølge et hvilket som helst af kravene 1 til 10, hvor dosen til individet med et kropsmasseindeks (BMI) > 30 beregnes baseret på en beregnet kropsvægt svarende til et BMI på 30 under anvendelse af individets højde.

15

12. rhASM til anvendelse ifølge et hvilket som helst af kravene 1 til 11, hvor ASMD'en er Niemann Pick sygdom (NPD) type A, eller NPD type B.

13. rhASM til anvendelse ifølge et hvilket som helst af kravene 1 til 11, hvor det menneskelige individ har en mutation i genet, som koder for sur sphingomyelinase, hvor mutationen er:

20

- a) en missense-mutation, eventuelt hvor nævnte mutation er L302P, H421Y eller R496L; eller
- b) en deletion-mutation, eventuelt hvor nævnte mutation er Δ R608.

25

14. rhASM til anvendelse ifølge et hvilket som helst af kravene 1 til 13, hvor doserne indgives intravenøst.

15. rhASM til anvendelse ifølge et hvilket som helst af kravene 1 til 14, hvor det menneskelige individ er et menneskebarn.

30

DRAWINGS

Drawing

Phase 1 Study
Patient Flow

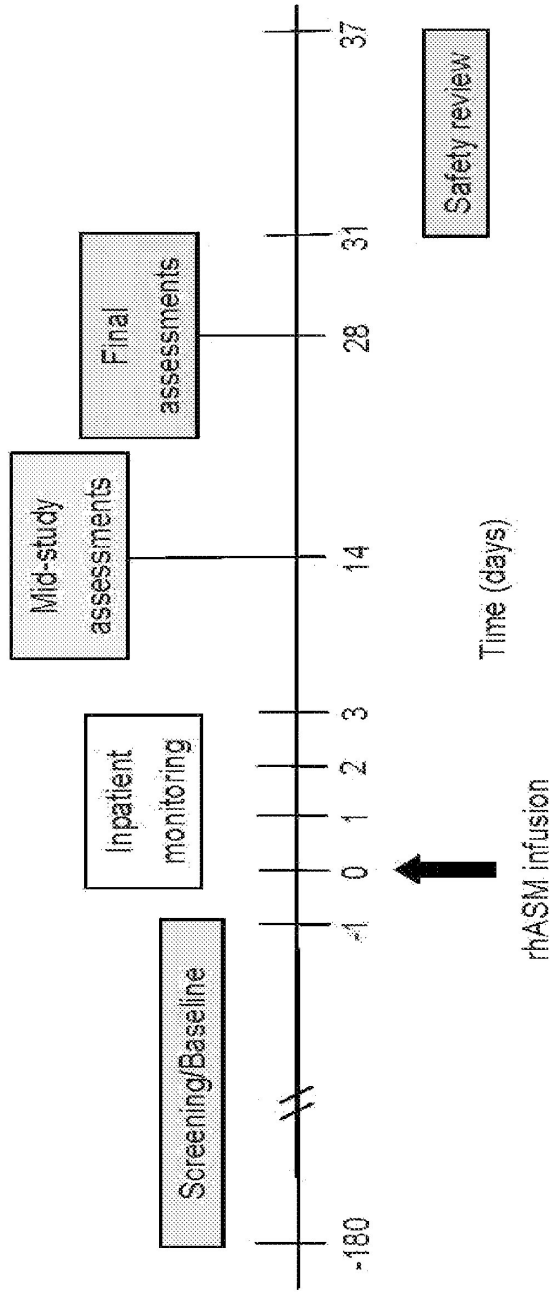

Fig. 1

Demography and Baseline Characteristics

Cohort Number	Dose (mg/kg)	Patient ID	Age at Infusion (yr)	Gender	Age at Symptom Onset (yr)	Age at Diagnosis (yr)	Spleen Volume (X norm)	ASM Activity (% norm)
1	0.03	10202	23	F	2.2	2.2	12.5	14
		10401	21	M	0.5	8.1	15.1	25
		10503	19	M	5.9	5.9	16.1	15
2	0.1	10804	45	F	88.7	38.7	4.8	14
		10605	26	F	2.9	3.3	12.8	17
		10906	41	F	9.6	9.6	8.7	29
3	0.3	10807	24	M	1.0	3.0	9.5	18
		11509	54	F	53.3	53.3	6.1	24
4	0.6	12010	18	M	Unknown	13.9	8.7	12
		12313	18	M	1.4	3.0	10.1	6
5	1.0	12112	46	M	3.5	3.5	14.5	6

Fig. 2

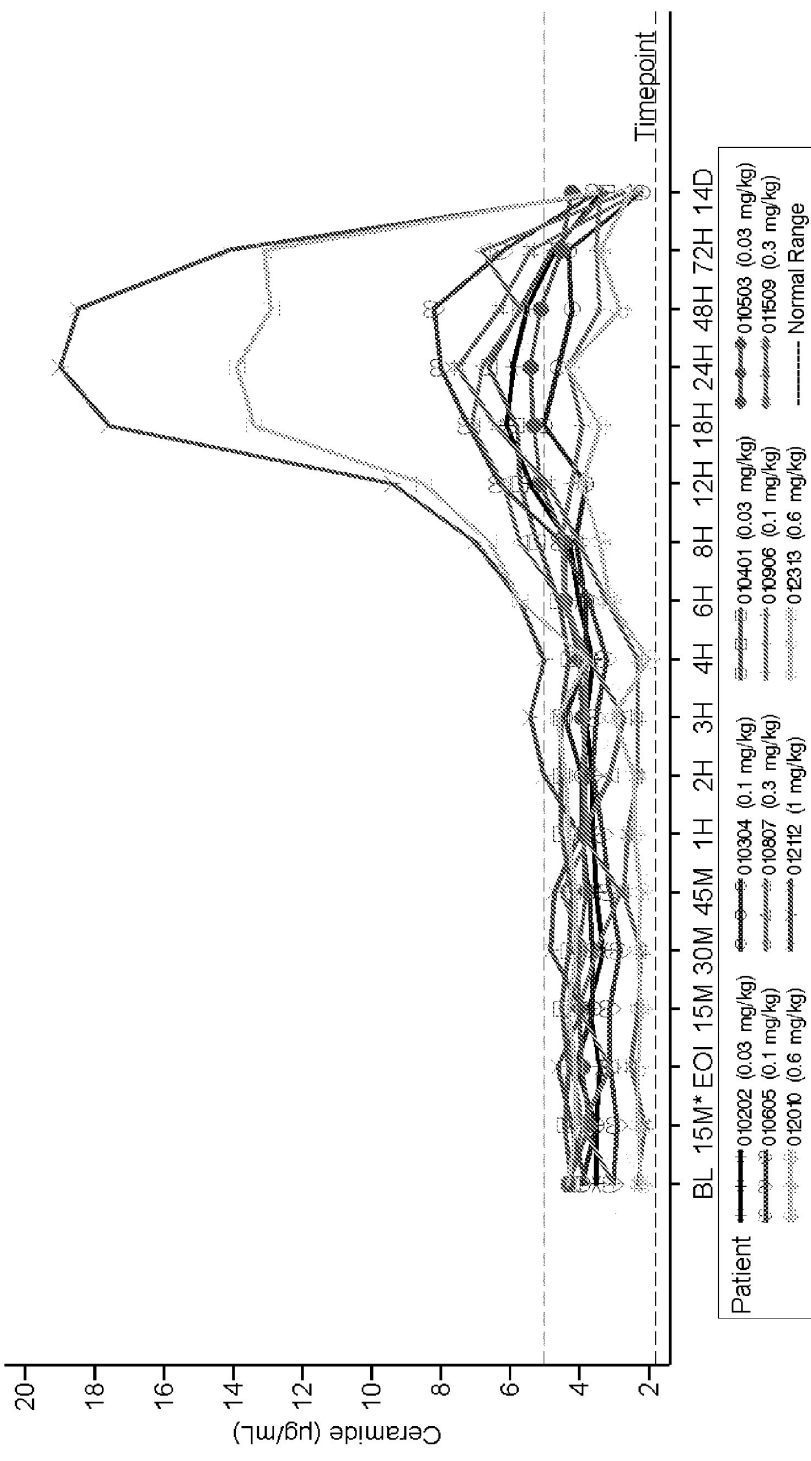

Fig. 3A

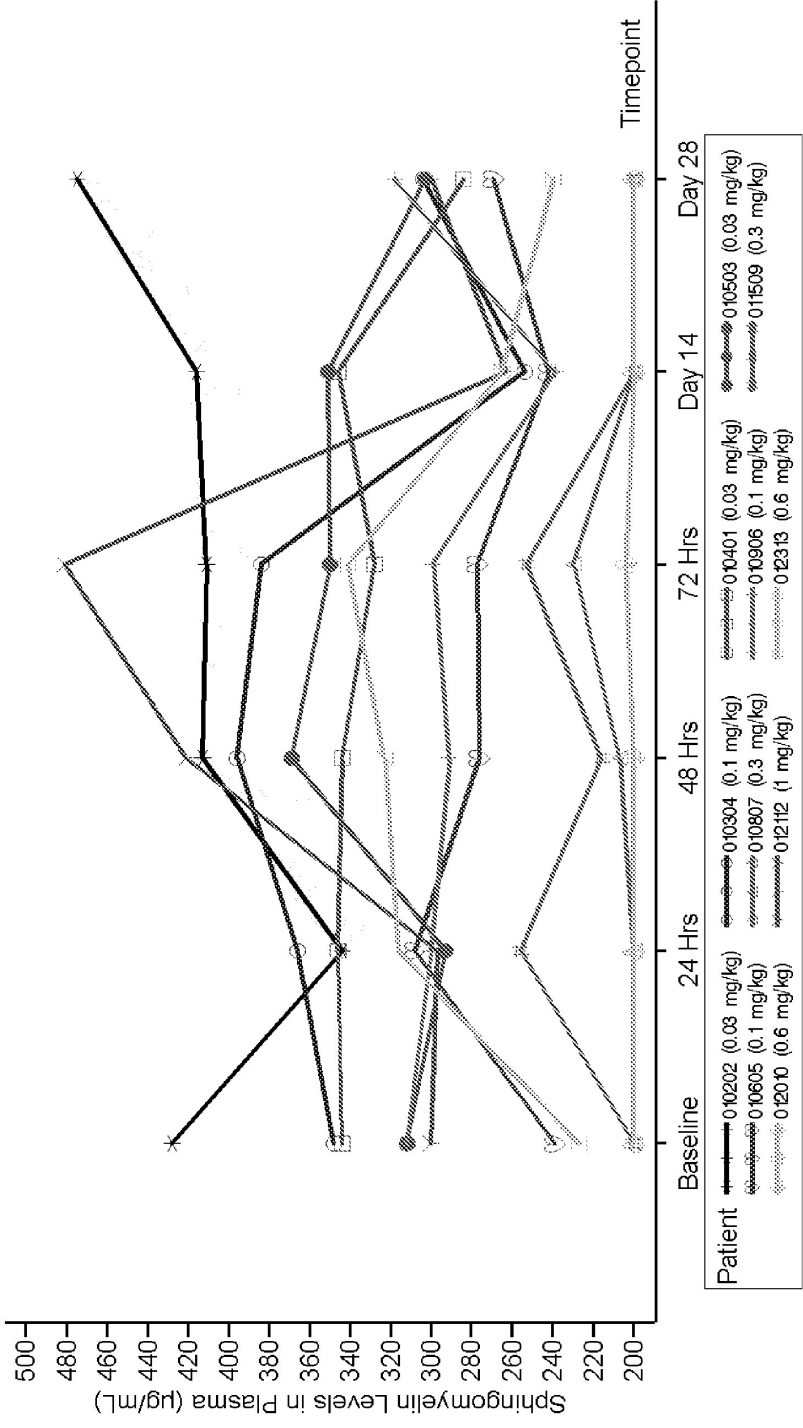

Fig. 3B

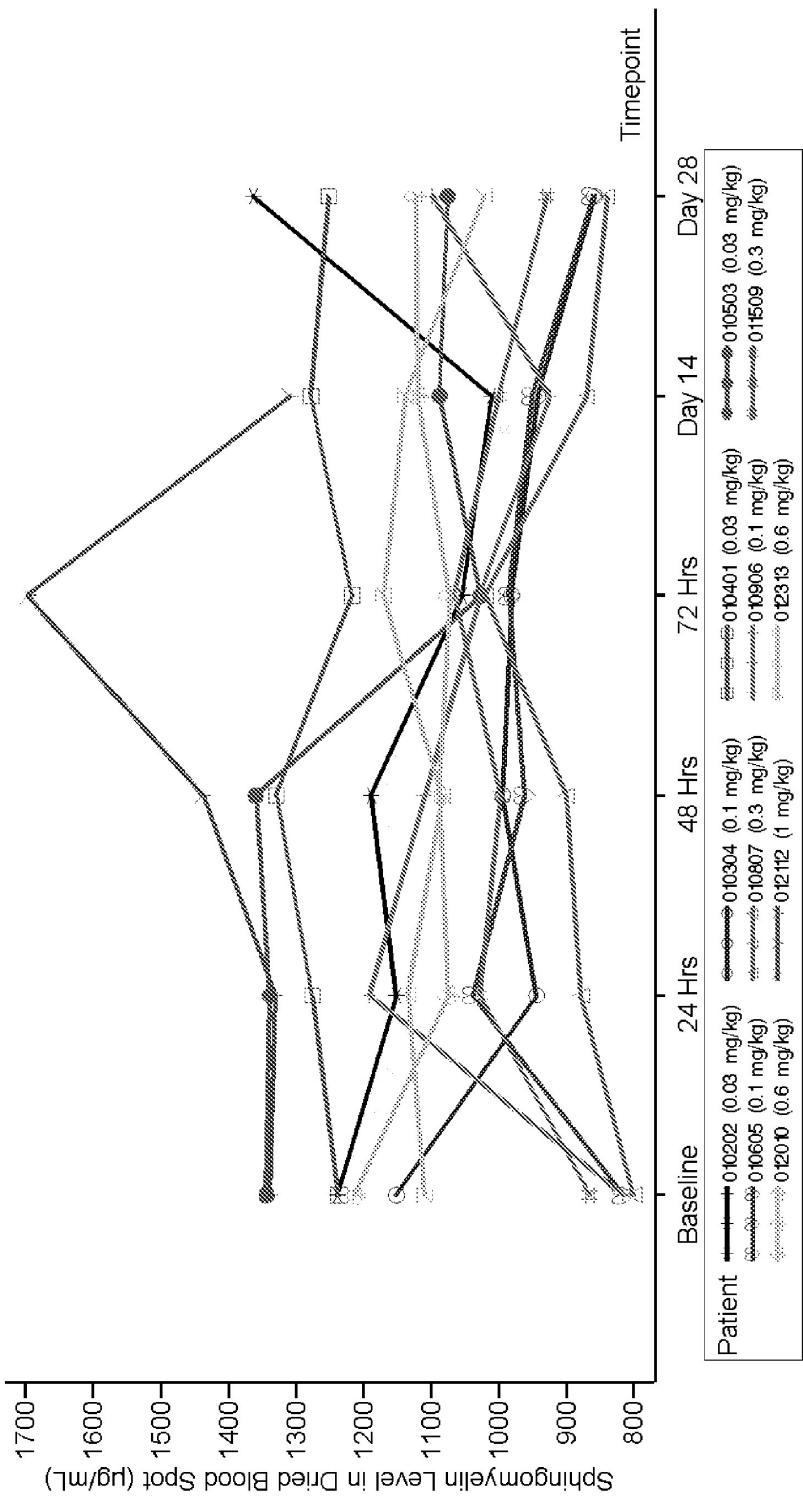

Fig. 3C

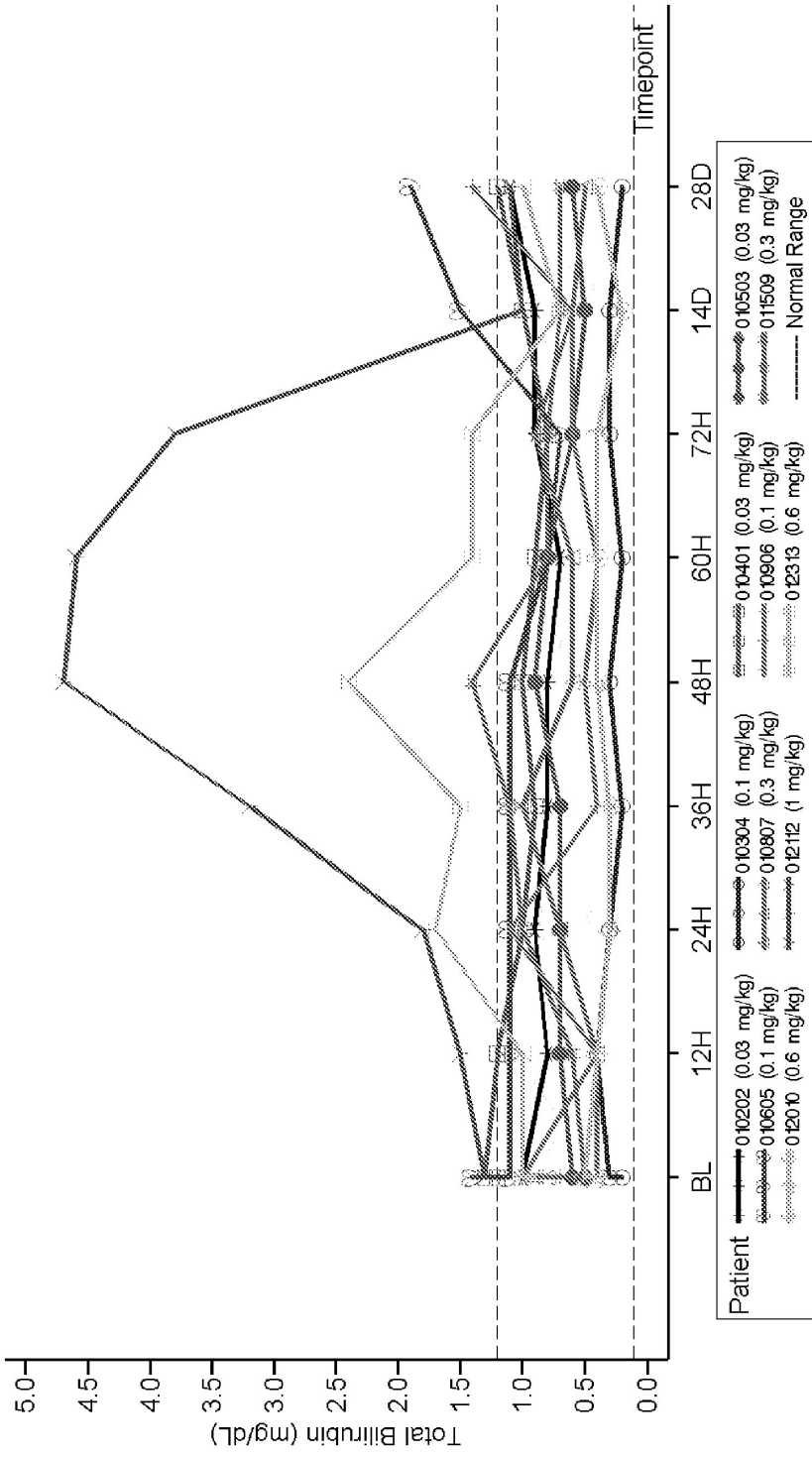

Fig. 4

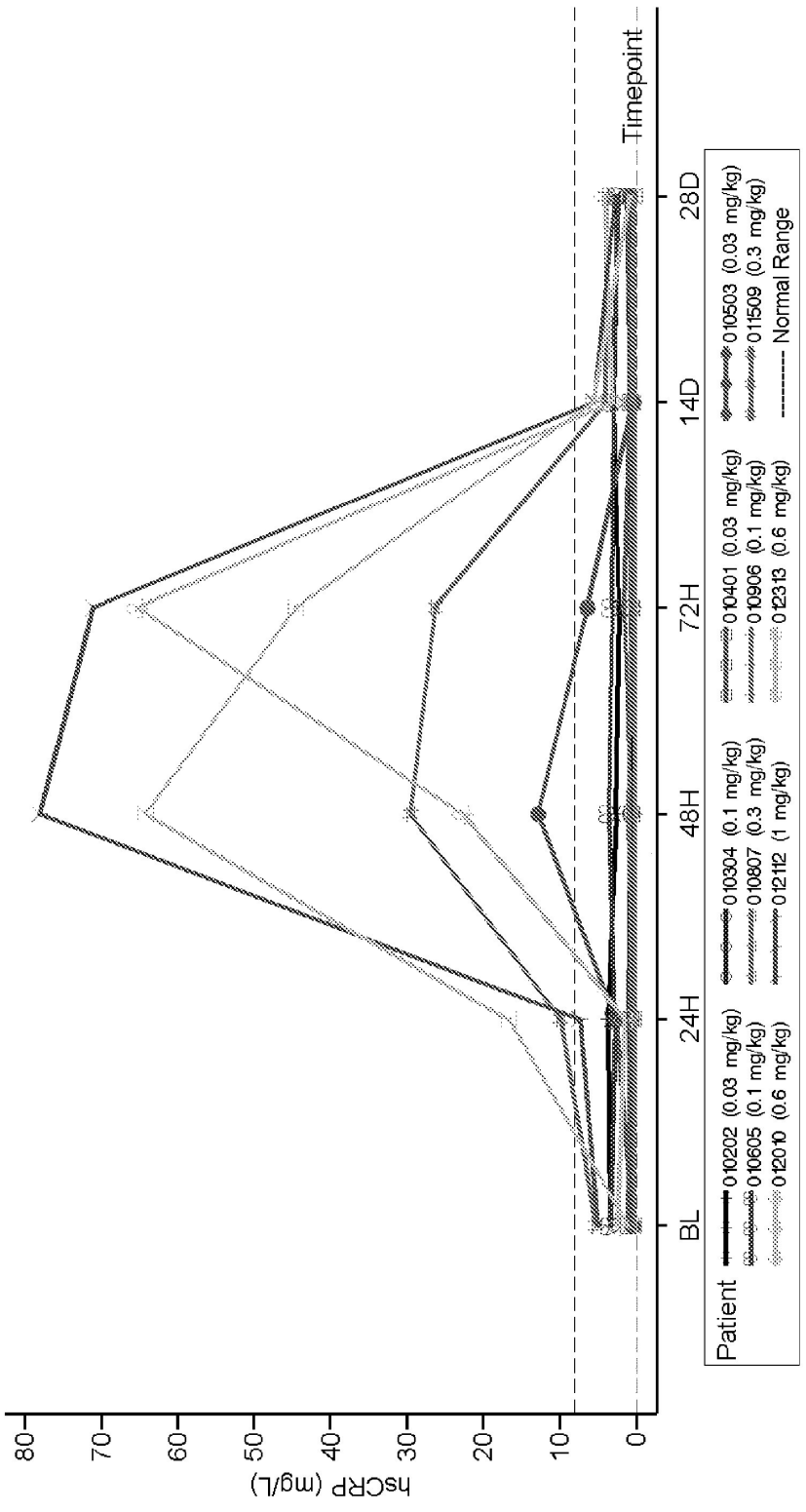

Fig. 5A

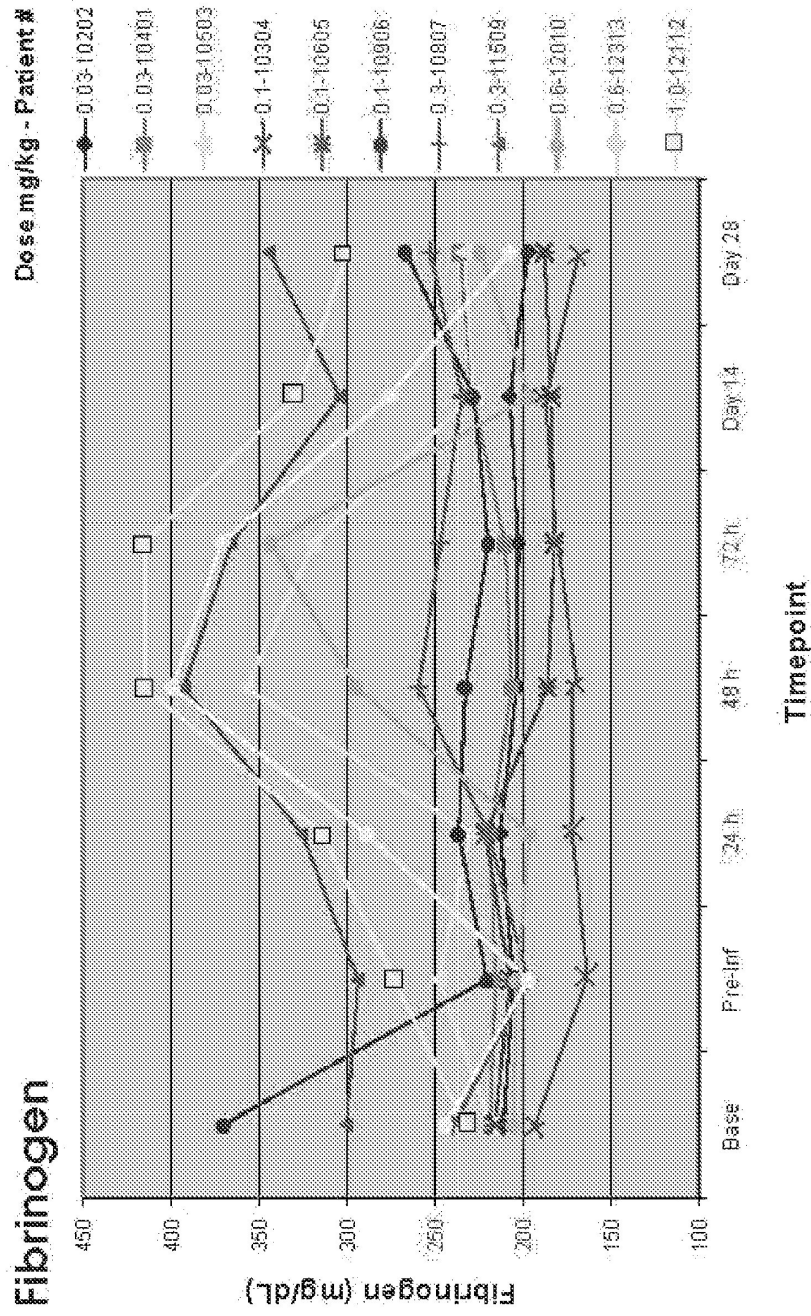

Fig. 5B

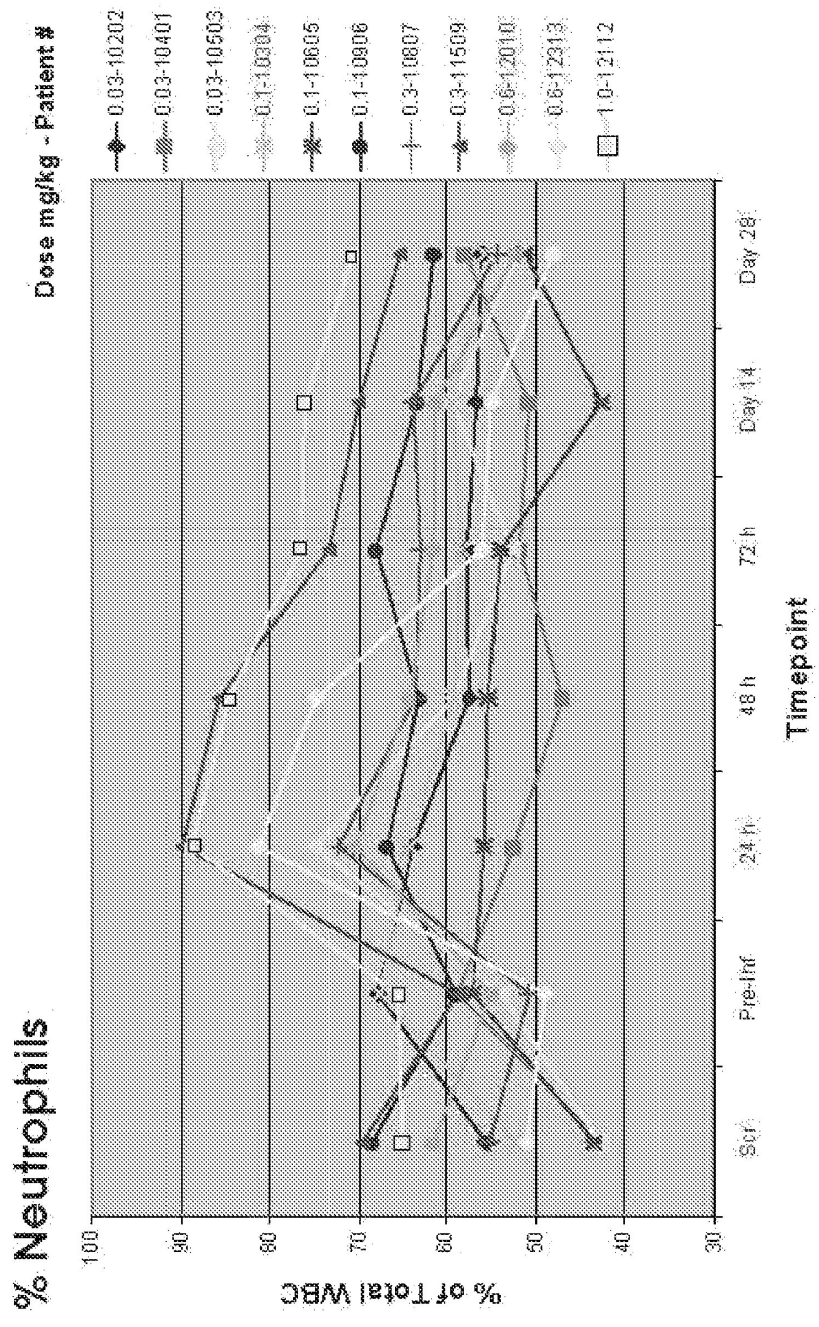

Fig. 5C

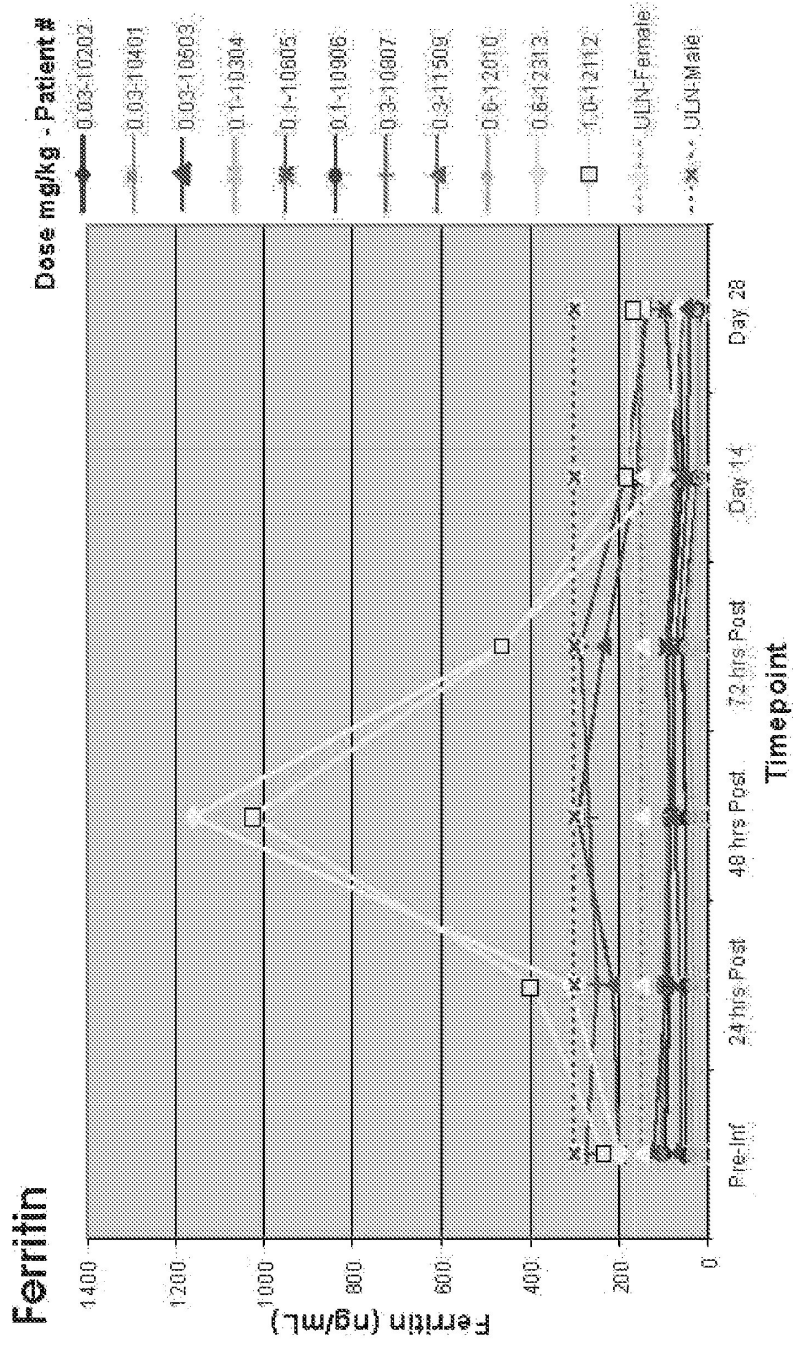

Fig. 5D

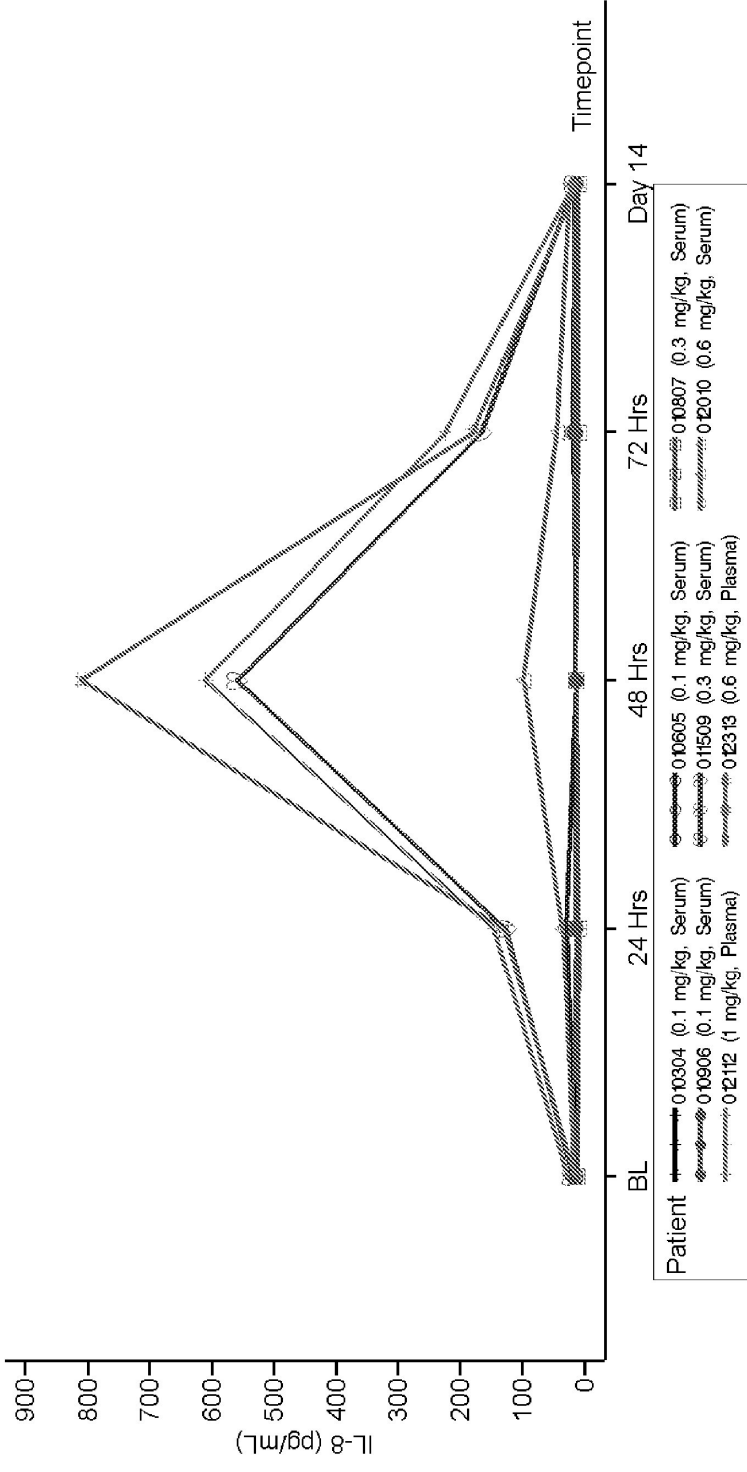

Fig. 5E

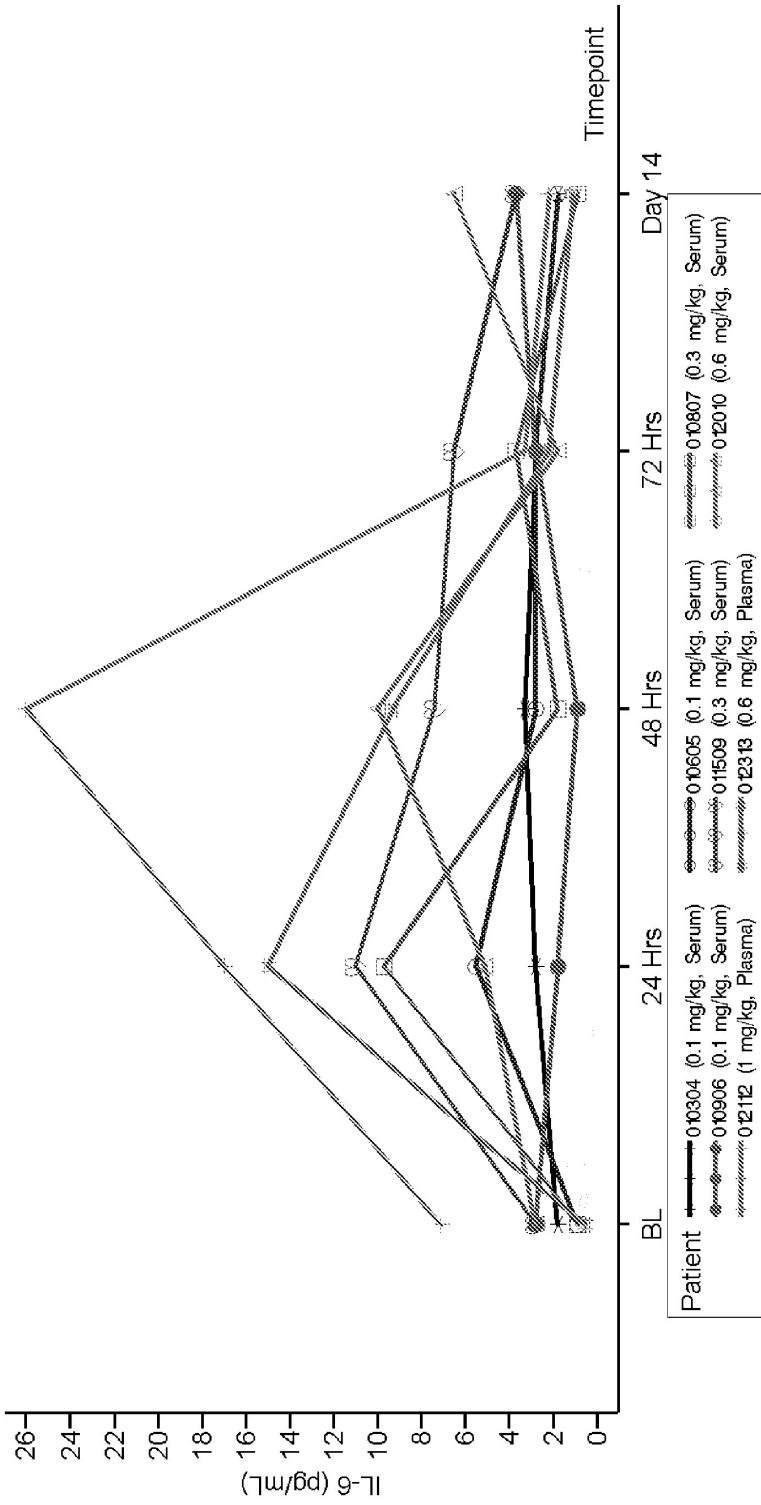

Fig. 5F

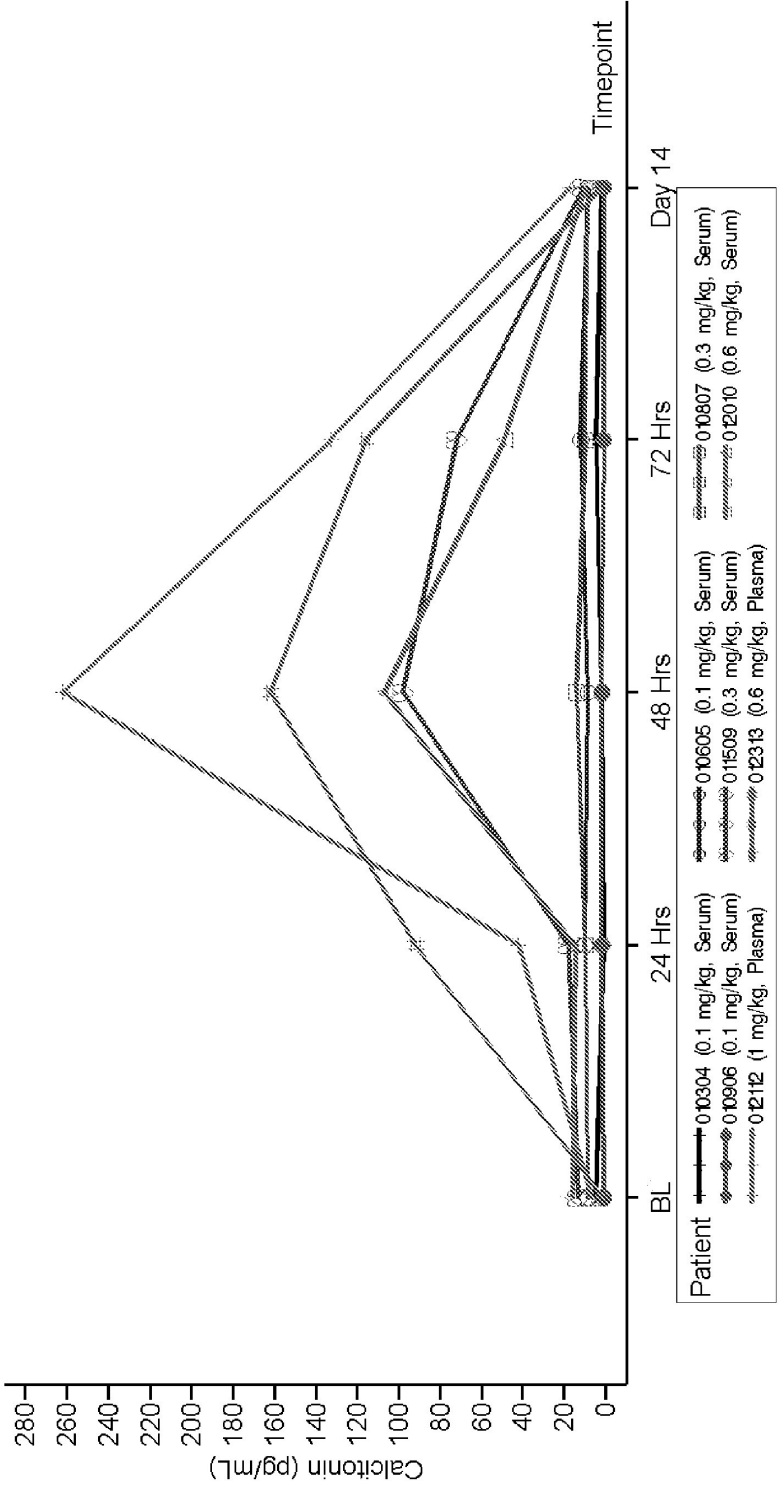

Fig. 5G

**Treatment Emergent Adverse Events Considered Related
(Possibly, Probably, or Definitely) to Treatment**

Dose (mg/kg)	Patient No.	Adverse Event	Start Day	Severity	Action Taken
0.3	11509	Fever	2	Moderate	None
		Myalgia	2	Moderate	None
		Nausea	2	Moderate	None
		Acute phase reaction	2	Moderate	None
0.6	12010	Leg pain	1	Moderate	None
		Abdominal pain	2	Mild	None
		Hip pain	2	Moderate	None
		Acute phase reaction	3	Moderate	None
		Acute phase reaction	2	Moderate	None
0.6	12313	Elevated bilirubin	2	Moderate	None
		Lymphocytic infiltrate/hepatocellular degeneration (liver biopsy)	14	Moderate	None
		Nausea/vomiting	1	Moderate	Medication
		Elevated bilirubin	3	Severe	None
1.0	12112	Fever	2	Moderate	Medication
		Fatigue	2	Moderate	None
		Acute phase reaction	2	Moderate	None
		Urobilinogen in urine	3	Moderate	None
		Scleral icterus	3	Moderate	None
		Increased fibrin D-dimer	29	Moderate	None

Fig. 6

Primary Treatment Period – Dose Escalation and Dose Maintenance Phases

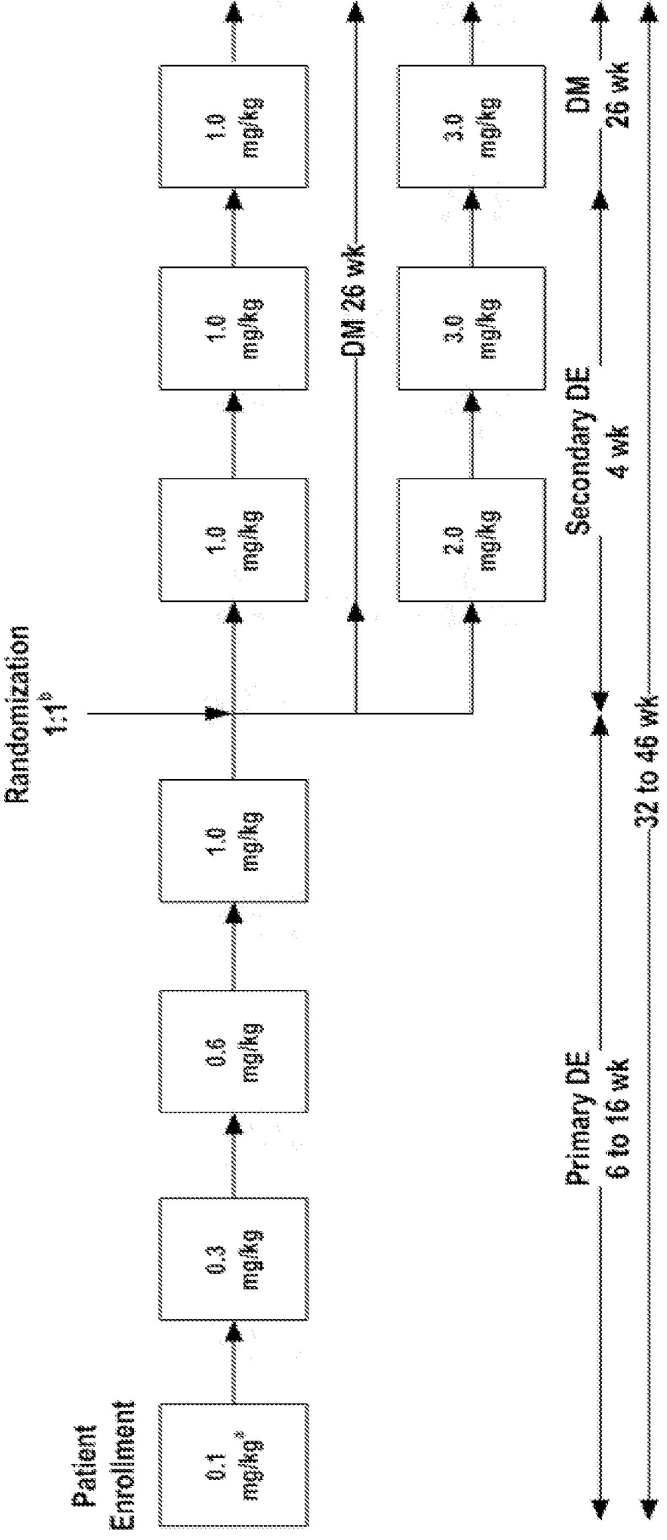

^a If the first 2 doses are not tolerated, the patient can be discontinued and replaced.

^b Stratified by spleen volume (< 12 and ≥ 12 MN).

Note: Dosing every 2 weeks (± 5 days). Figure does not include re-challenge doses.
 DE = Dose Escalation; DM = Dose Maintenance; MN = Multiples of normal; wk = week(s).

Fig. 7